

# Understanding Mathematics

## Student's Activity Book for Class 2

Name: .....

Section: .....

School: .....



Department of School Education  
Ministry of Education and Skills Development  
Royal Government of Bhutan  
Thimphu

Copyright © 20234 Department of School Education (DSE)

Ministry of Education and Skills Development (MoESD), Royal Government of Bhutan.

All rights reserved. No part of this book may be reproduced in any form without the prior written permission from the DSE, MoESD, Royal Government of Bhutan.

Telephone: +975-2-332885/332880

Toll Free: 1850

Website: [www.education.gov.bt](http://www.education.gov.bt)

ISBN: 978-99936-0-844-7-3    First Edition 2010  
Second Edition 2011  
Reprint 2024

**Concept and Writing**

Karma Yeshey, DCRD, Ministry of Education

# CONTENTS

Introduction		iv
Chapter 1	Numbers to 100	1
Chapter 2	Addition and Subtraction Strategies	12
Chapter 3	Measuring Length and Area	27
Chapter 4	Place Value	33
Chapter 5	Fractions	39
Chapter 6	Geometry	44
Chapter 7	Two-digit Addition and Subtraction	61
Chapter 8	Numbers Greater than 100	73
Chapter 9	Data and Probability	83
Chapter 10	Measuring Mass, Capacity and Time	89
Summative Assessment Recording Sheets		99

## INTRODUCTION

This **Student Activity Book for Class 2** is to be introduced in the schools from the year 2013, along with the new **Mathematics Teacher's Guide** for the same class. The term "activity book" means the same as what is usually called "Workbook".

This Student Activity Book for Class 2 in mathematics is expected to fulfill the long desired need for such a book. This is something that the teachers have been expressing a wish for during the last several years even with the old mathematics curriculum.

The mathematics curriculum emphasizes hands-on, practical, communication and reasoning intensive classroom activities often intended for group or pair-based engagement. It espouses students' capacity to discover ideas, to deepen their reasoning skills, to build on their intuitions, to arrive at common generalizations, and to create (or recreate) knowledge. The Teacher's Guide will aid the teachers in carrying out this curricular intention. The activities in the Activity Book, although paper-and-pencil based, are designed to support the activities suggested in the Teacher's Guide.

Following are some pertinent points related to this activity book and its intended manner of use.

- The activities in this book serve as extensions of and support to the normal classroom activities. They cannot replace the activities mentioned or suggested in the Teacher's Guide.
- The activities for each chapter are generally intended for use along the course of the lessons or at the end of teaching the chapter, rather than at the outset.
- The students should normally do and complete the activities during the class hours under the close guidance of the teacher.
- The teacher should engage the students in verbal discussions on the activities to extend beyond simply completing the activities, wherever possible and appropriate. Many of the activities have this opportunity built in them.
- Some of the activities could be done in more than one valid way, depending on how the students reason with the problem. That is why it would be important to ask the students for their reasons, where appropriate.
- The *Teacher's Remark(s)* space provided below each activity is intended to provide a space in which the teacher may record any useful and interesting anecdotes concerning the child and the particular activity. The anecdotal records could also help the teacher in assessing the student's learning. The space could also be used to communicate messages to the parents and caregivers of the child.
- The *Summative Assessment Recording Sheets* included at the end of the book are meant for the teacher to record the student's understanding and achievement of the learning goals for each chapter assessed through the means of *Interview-based Performance Tasks*. The teacher could remove these sheets from the book and maintain them in separate files for the student's assessment records.
- There is no assumption that this activity book, beside the Teacher's Guide, would be sufficient as a programme of studies for mathematics in Class 2. The teacher is encouraged to go beyond what is presented here to make additional activity sheets for the students, as needed.

The Primary Mathematics Section, REC, would like to welcome comments and feedback from teachers and other users of this activity book that may contribute to its improvement. We wish success and enjoyment in the teaching and learning of mathematics for teachers and students.

Trashi Delek.

Write the missing numbers for the number lines.

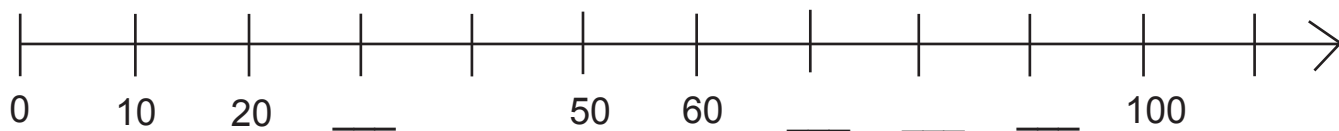
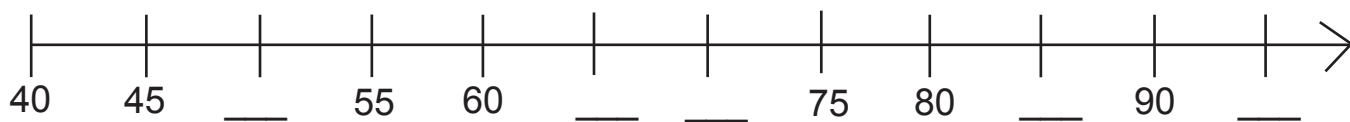
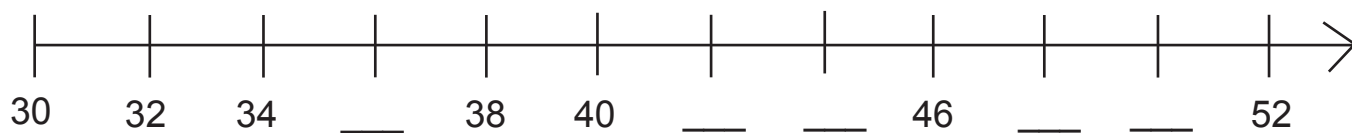
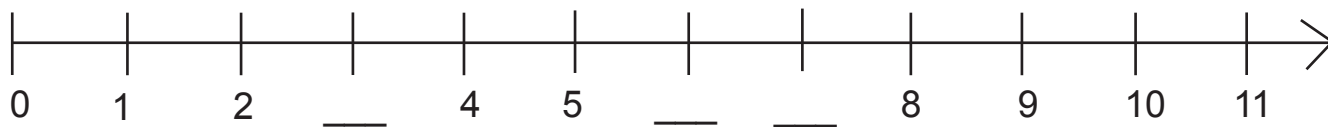

Teacher's Remark(s):

Teacher's Signature and Date:

Write the missing numbers in each sequence.

Skip count by 5s: 35, 30, 25, \_\_\_\_\_, 15, \_\_\_\_\_, \_\_\_\_\_, \_\_\_\_\_

Skip count by 10s: 100, 90, \_\_\_\_\_, 70, 60, \_\_\_\_\_, 40, \_\_\_\_\_, \_\_\_\_\_

Skip count by 2s: 30, 28, \_\_\_\_\_, \_\_\_\_\_, 22, \_\_\_\_\_, \_\_\_\_\_, 16

Skip count by 1s: 11, 10, 9, \_\_\_\_\_, \_\_\_\_\_, 6, \_\_\_\_\_, 4, 3, 2, 1

Skip count by 10s: 50, 40, \_\_\_\_\_, \_\_\_\_\_, \_\_\_\_\_, \_\_\_\_\_

Skip count by 5s: 50, \_\_\_\_\_, 40, \_\_\_\_\_, 30, 25, \_\_\_\_\_, 15, \_\_\_\_\_, 5

Skip count by 2s: 50, 48, \_\_\_\_\_, 44, \_\_\_\_\_, 40, \_\_\_\_\_, \_\_\_\_\_, 34

Skip count by 1s: \_\_\_\_\_, 49, 48, 47, \_\_\_\_\_, 45, \_\_\_\_\_, \_\_\_\_\_, \_\_\_\_\_, 41

Write the number of buttons below the three circle that contain them.  
 How many buttons do you think will be there in the empty circle? Write the number and draw the buttons.

\_\_\_\_\_

\_\_\_\_\_

\_\_\_\_\_

\_\_\_\_\_

Teacher's Remark(s): \_\_\_\_\_

Teacher's Signature and Date: \_\_\_\_\_

First, estimate the number of items in each set and write down your estimates. Then, count and write the actual number of items for each set.

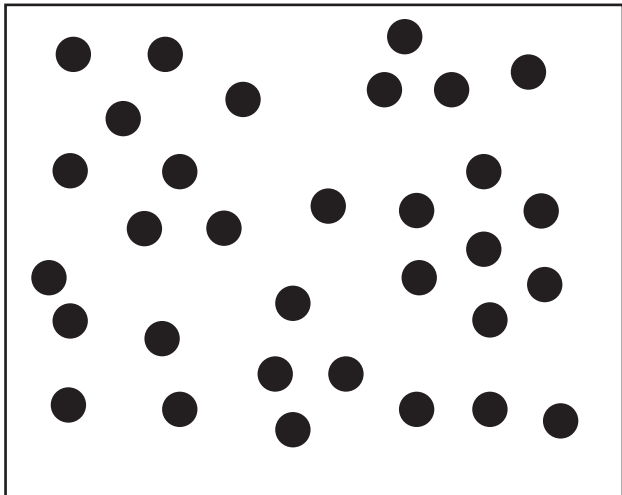

My estimate: \_\_\_\_\_ Count: \_\_\_\_\_

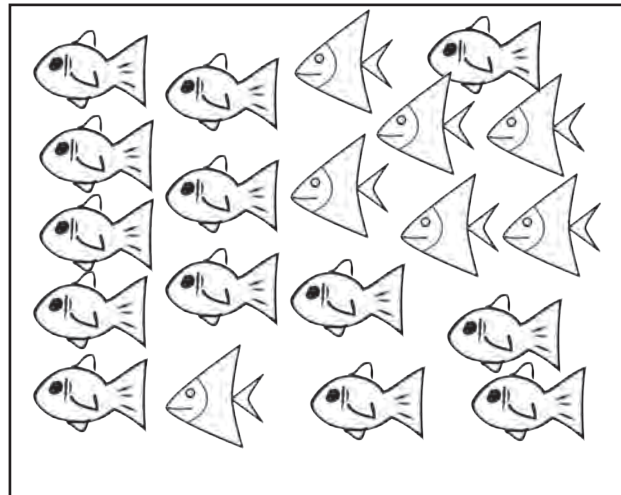

My estimate: \_\_\_\_\_ Count: \_\_\_\_\_

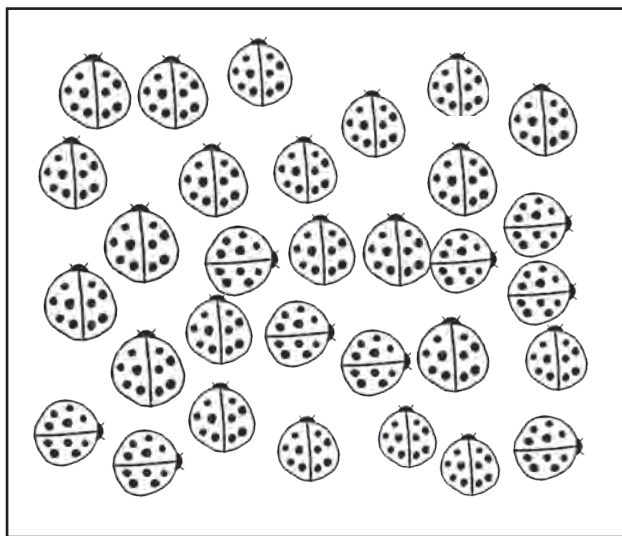

My estimate: \_\_\_\_\_ Count: \_\_\_\_\_

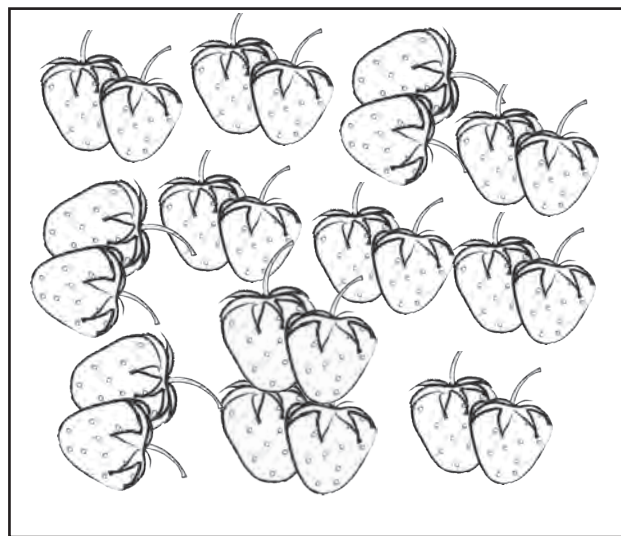

My estimate: \_\_\_\_\_ Count: \_\_\_\_\_

Teacher's Remark(s): \_\_\_\_\_

Teacher's Signature and Date: \_\_\_\_\_

What number does each set show?

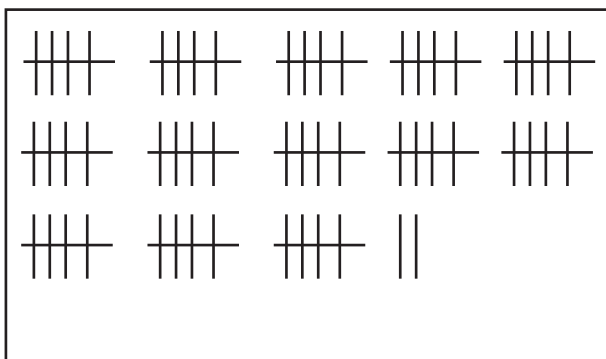

\_\_\_\_\_

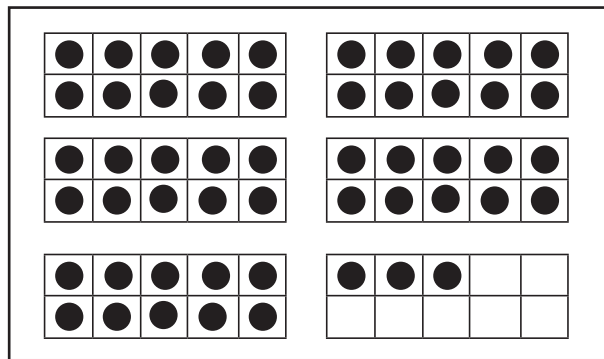

\_\_\_\_\_

Show the numbers below the sets by drawing counters on the 10-frames.

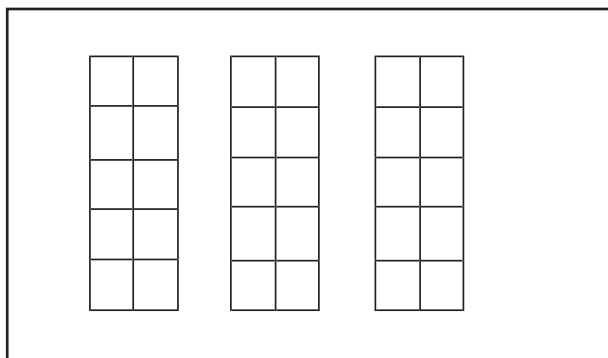

25

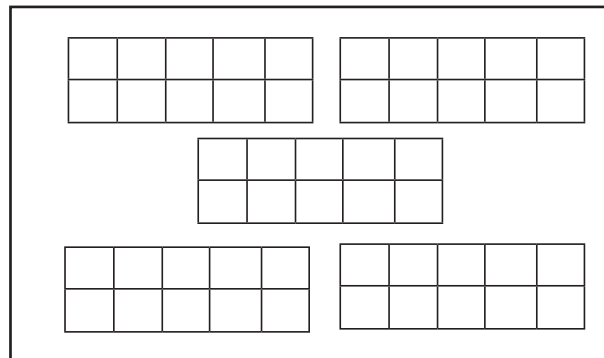

43

Show the numbers below the sets by drawing tally marks.

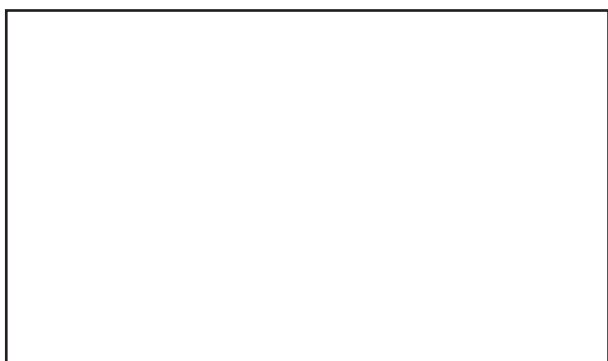

43

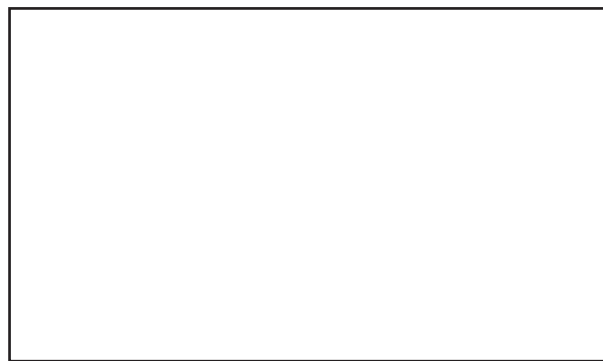

17

Teacher's Remark(s):

Teacher's Signature and Date:



Mark each pair of numbers on the number lines. Then, circle the greater number.

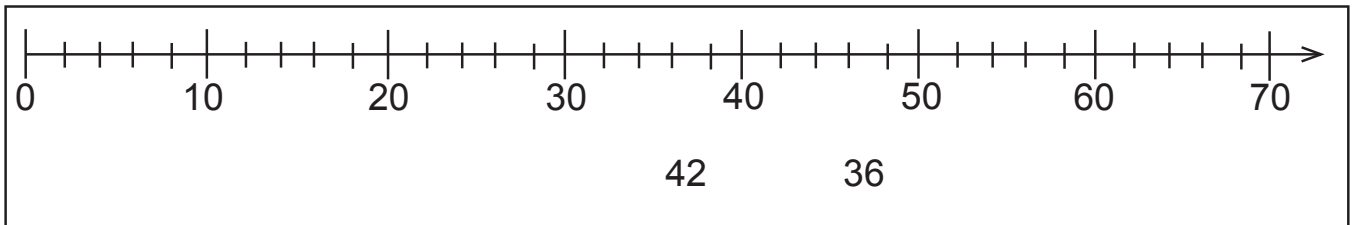
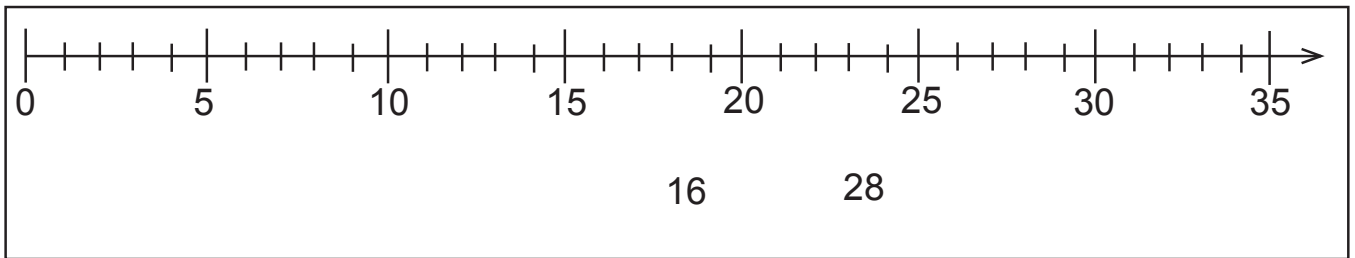
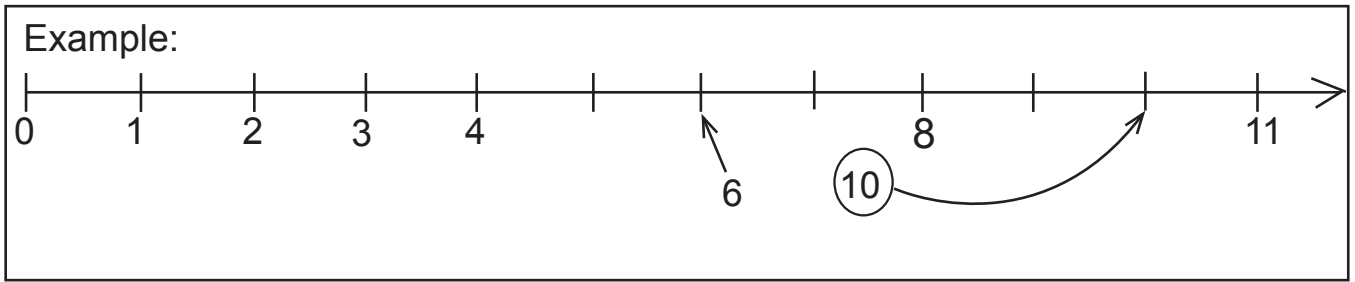

Compare the pairs of numbers and write “is more than” or “ is less than” between them.

Example: 25 is more than 20      60 \_\_\_\_\_ 70

15 \_\_\_\_\_ 17      15 \_\_\_\_\_ 10

Compare the pairs of numbers and insert > or < between them.

Example: 25 > 20      60 \_\_\_\_\_ 70      2 \_\_\_\_\_ 3

20 \_\_\_\_\_ 17      5 \_\_\_\_\_ 10      3 \_\_\_\_\_ 2

13 \_\_\_\_\_ 23      51 \_\_\_\_\_ 49      12 \_\_\_\_\_ 21

Teacher’s Remark(s):

Teacher’s Signature and Date:

Write the numbers in the 100-chart, and answer the questions.

1									
				35					
									100

1. What number is 1 more than 35?

---

2. What number is 10 more than 35?

---

3. What number is 5 less than 70?

---

4. Write down two numbers which are more than 95.

---

5. Write down all the numbers which are less than 7.

---

Teacher's Remark(s):

Teacher's Signature and Date:

Study each of the following number patterns and complete the sentences by writing the words, “repeating”, “growing” or “shrinking”.

2, 4, 6, 8, 10, ... This is a \_\_\_\_\_ pattern.

1, 2, 3, 4, 5, ... This is a \_\_\_\_\_ pattern.

1, 2, 1, 2, 1, 2, .... This is a \_\_\_\_\_ pattern.

30, 25, 20, 15, .... This is a \_\_\_\_\_ pattern.

3, 3, 6, 3, 3, 6, 3, 3, 6, ... This is a \_\_\_\_\_ pattern.

5, 10, 15, 20, 25, 30, ... This is a \_\_\_\_\_ pattern.

100, 90, 80, 70, ... This is a \_\_\_\_\_ pattern.

Create a repeating number pattern.

Create a growing number pattern.

Create a shrinking number pattern.

---

Teacher's Remark(s):

Teacher's Signature and Date:

Extend the number patterns.

2, 4, 6, 8, ...

5, 10, 15, 20, ...

75, 80, 85, ...

75, 70, 65, 60, ...

15, 14, 13, 12, ...

4, 8, 4, 8, 4, 8, ...

4, 8, 12, 4, 8, 12, 4, 8, 12, ...

1, 3, 5, 7, 9, ...

Create a pattern which starts with 10 and the numbers grow by 10 each time.

Create a pattern which starts with 40 and the numbers grow by 5 each time.

Create a pattern which starts with 40 and the numbers decrease by 5 each time.

Create a pattern which starts with 10 and the numbers grow by 2 each time.

---

Teacher's Remark(s):

Teacher's Signature and Date:

Write the double for each of the numbers below.

Number	1	2	3	4	5	6	7	8	9	10	11
Double											

Circle the even numbers.

1    2    3    4    5    6    7    8    9    10    11    12  
13   14   15   16   17   18   19   20   21   22   23   24  
25   26   27   28   29   30   31   32   33   34   35   36

Circle the odd numbers.

1    2    3    4    5    6    7    8    9    10    11    12  
13   14   15   16   17   18   19   20   21   22   23   24

Show that 8 is an even number by drawing rectangles.

Show that 5 is not an even number with the drawing of rectangles.

---

Teacher's Remark(s):

Teacher's Signature and Date:

Make a calendar for the month of February this year, and answer the questions.

Month: February Year: _____						
Sunday	Monday	Tuesday	Wednesday	Thursday	Friday	Saturday

1. How many days are there in February this year?

\_\_\_\_\_

2. What day is the 1<sup>st</sup> of February?

\_\_\_\_\_

3. What day is the 28<sup>th</sup> of February?

\_\_\_\_\_

4. What dates fall on the Sunday?

\_\_\_\_\_

5. On what date did you report to the school this year?

\_\_\_\_\_

6. When is the birthday of our King, His Majesty Jigme Khesar Namgyal Wangchuck?

\_\_\_\_\_

Teacher's Remark(s):

Teacher's Signature and Date:

Make a calendar for the month of March this year, and answer the questions.

Month: March    Year: _____						
Sunday	Monday	Tuesday	Wednesday	Thursday	Friday	Saturday

1. How many days are there in March?

\_\_\_\_\_

2. Write down the dates that fall on the Wednesday of March.

\_\_\_\_\_

4. Write in words the following dates.

1 <sup>st</sup>	first
2 <sup>nd</sup>	
3 <sup>rd</sup>	
4 <sup>th</sup>	
5 <sup>th</sup>	
6 <sup>th</sup>	
7 <sup>th</sup>	
8 <sup>th</sup>	
9 <sup>th</sup>	
10 <sup>th</sup>	

11 <sup>th</sup>	
12 <sup>th</sup>	
13 <sup>th</sup>	
21 <sup>st</sup>	twenty-first
22 <sup>nd</sup>	
23 <sup>rd</sup>	
24 <sup>th</sup>	
25 <sup>th</sup>	
26 <sup>th</sup>	
27 <sup>th</sup>	

Teacher's Remark(s):

Teacher's Signature and Date:

Write an addition or a subtraction sentence for each of the stories below.

Example:

1. Three dogs were playing. Three more dogs joined them. Now there are six dogs.

$$3 + 3 = 6$$

2. Tenzin has six marbles. His brother gave him 3 more marbles. Now he has nine marbles.
3. Seven deer were eating grass in a meadow. Two of them left the meadow after sometime. Now there are five deer in the meadow.
4. Maya has ten ngultrums. Mani also has ten ngultrums. Maya and Mani together have twenty ngultrums.
5. Yangchen has two chocolates. She gave one chocolate to her brother. Now she has one chocolate.
6. Pema has eight pencils. Kumari has 5 pencils. How many more pencils does Pema have than Kumari?

---

Teacher's Remark(s):

Teacher's Signature and Date:

---



Write a short story each for the following addition and subtraction sentences. You can also draw pictures for your stories.

$$5 + 2 = 7$$

$$5 - 3 = 2$$

$$5 + 5 = 10$$

---

Teacher's Remark(s):

Teacher's Signature and Date:

Find the **sum** for the following additions using the number lines.

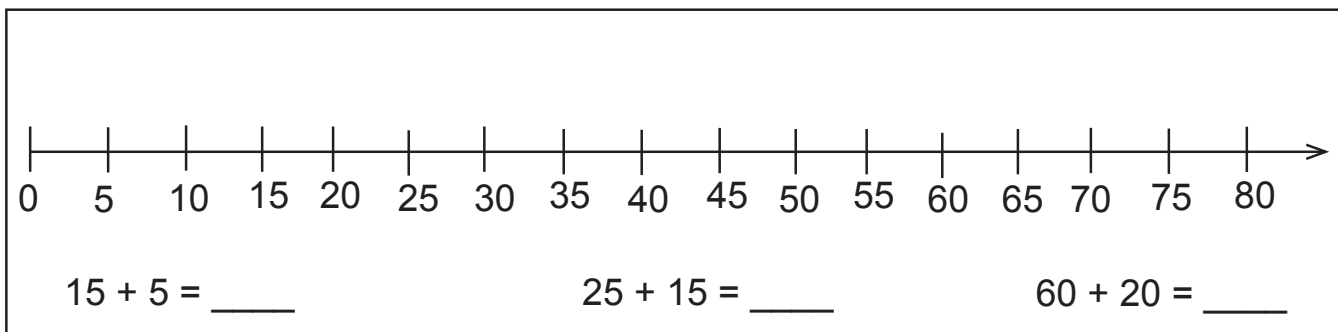
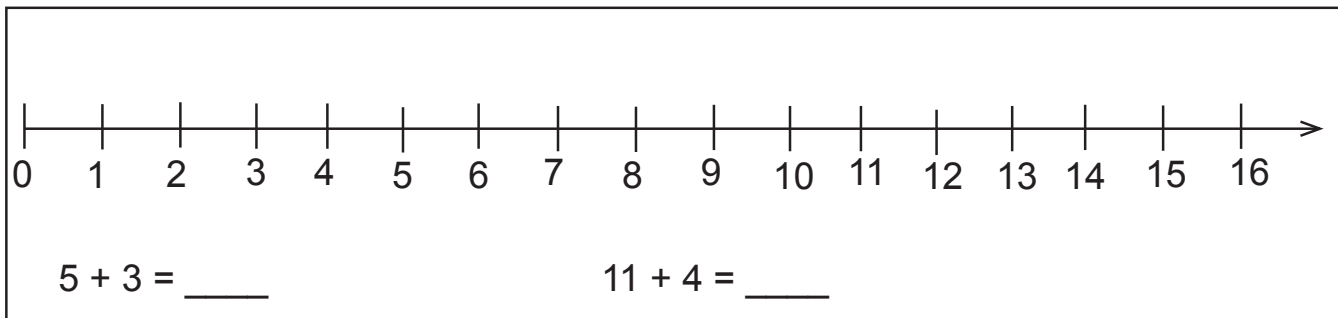

Find the **differences** for the following subtractions using the number lines.

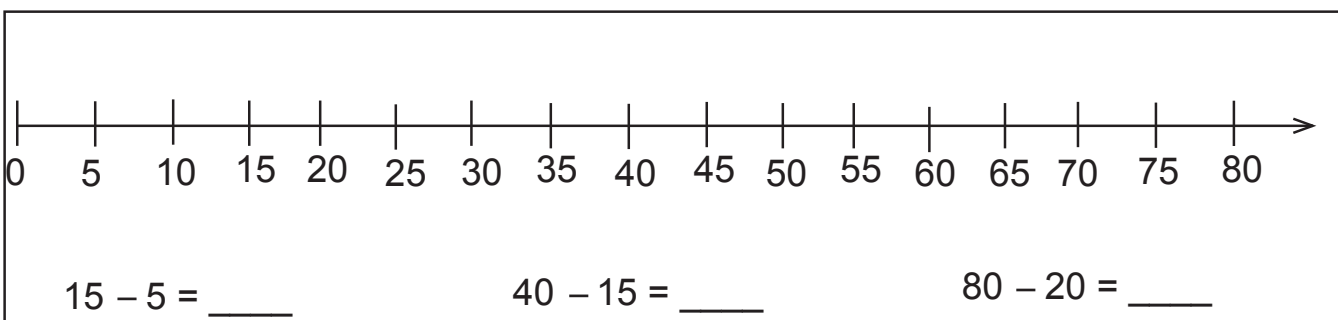
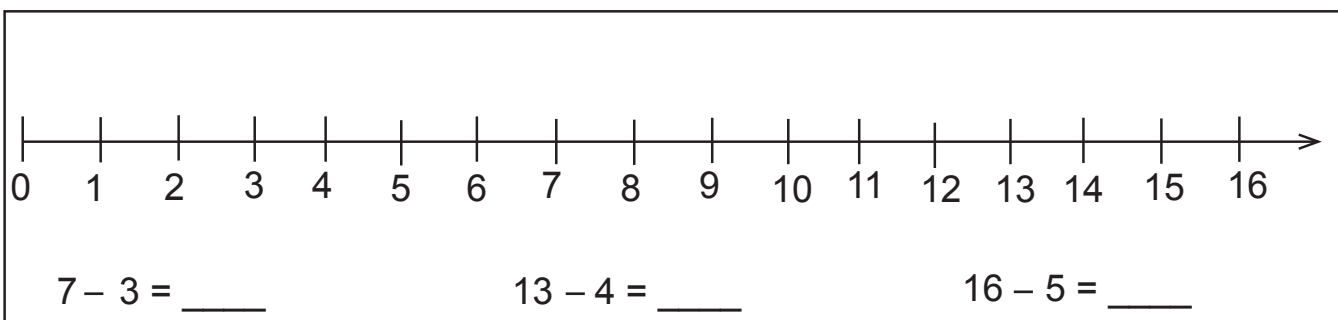

Teacher's Remark(s):

Teacher's Signature and Date:

Write down the **sums** for the following additions.

$1 + 1 = \underline{\quad}$

$6 + 6 = \underline{\quad}$

$2 + 2 = \underline{\quad}$

$7 + 7 = \underline{\quad}$

$3 + 3 = \underline{\quad}$

$8 + 8 = \underline{\quad}$

$4 + 4 = \underline{\quad}$

$9 + 9 = \underline{\quad}$

$5 + 5 = \underline{\quad}$

$10 + 10 = \underline{\quad}$

Use the above **double facts** to determine the **sums** for the following additions.

$3 + 4 = \underline{\quad}$

$7 + 6 = \underline{\quad}$

$4 + 5 = \underline{\quad}$

$7 + 8 = \underline{\quad}$

$5 + 4 = \underline{\quad}$

$8 + 7 = \underline{\quad}$

$5 + 7 = \underline{\quad}$

$8 + 9 = \underline{\quad}$

$6 + 5 = \underline{\quad}$

$9 + 10 = \underline{\quad}$

$6 + 8 = \underline{\quad}$

$10 + 9 = \underline{\quad}$

---

Teacher's Remark(s):

Teacher's Signature and Date:

---

Use the given fact to find the difference

1)  $2 - 1 = \underline{1}$

$2 - 2 = \underline{\quad}$

$2 - 0 = \underline{\quad}$

2)  $4 - 2 = \underline{\quad}$

$4 - 3 = \underline{1}$

$4 - 1 = \underline{\quad}$

3)  $6 - 3 = \underline{\quad}$

$6 - 4 = \underline{\quad}$

$6 - 2 = \underline{4}$

4)  $8 - 4 = \underline{\quad}$

$8 - 5 = \underline{3}$

$8 - 3 = \underline{\quad}$

5)  $12 - 6 = \underline{6}$

$12 - 5 = \underline{\quad}$

$12 - 7 = \underline{\quad}$

6)  $14 - 7 = \underline{\quad}$

$14 - 6 = \underline{8}$

$14 - 8 = \underline{\quad}$

---

Teacher's Remark(s):

Teacher's Signature and Date:

---

Complete the **facts for 10**.

$10 = 9 + \underline{\quad}$

$10 = \underline{\quad} + 9$

$10 = 8 + \underline{\quad}$

$10 = \underline{\quad} + 8$

$10 = 7 + \underline{\quad}$

$10 = \underline{\quad} + 7$

$10 = 6 + \underline{\quad}$

$10 = \underline{\quad} + 6$

$10 = 5 + \underline{\quad}$

$10 = \underline{\quad} + 5$

Use the above **facts for 10** to determine the sums for the following additions. You can show your workings on the sides.

Example:  $9 + 5 = \underline{14}$       $(9 + 5 = 9 + 1 + 4 = 10 + 4 = 14)$

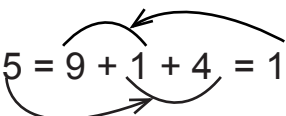

$9 + 4 = \underline{\quad}$

$8 + 5 = \underline{\quad}$

$8 + 6 = \underline{\quad}$

$7 + 6 = \underline{\quad}$

$5 + 6 = \underline{\quad}$

$5 + 7 = \underline{\quad}$

$5 + 8 = \underline{\quad}$

$9 + 7 = \underline{\quad}$

---

Teacher's Remark(s):

---

Teacher's Signature and Date:

Look at the addition **facts for 10**, and complete the related subtraction facts.

$9 + 1 = 10$	$10 - 9 = \underline{\quad}$
$8 + 2 = 10$	$10 - 8 = \underline{\quad}$
$7 + 3 = 10$	$10 - 7 = \underline{\quad}$
$6 + 4 = 10$	$10 - 6 = \underline{\quad}$
$5 + 5 = 10$	$10 - 5 = \underline{\quad}$
$4 + 6 = 10$	$10 - 4 = \underline{\quad}$
$3 + 7 = 10$	$10 - 3 = \underline{\quad}$
$2 + 8 = 10$	$10 - 2 = \underline{\quad}$
$1 + 9 = 10$	$10 - 1 = \underline{\quad}$
$0 + 10 = 10$	$10 - 0 = \underline{\quad}$

Write a subtraction sentence for each of the following diagrams.

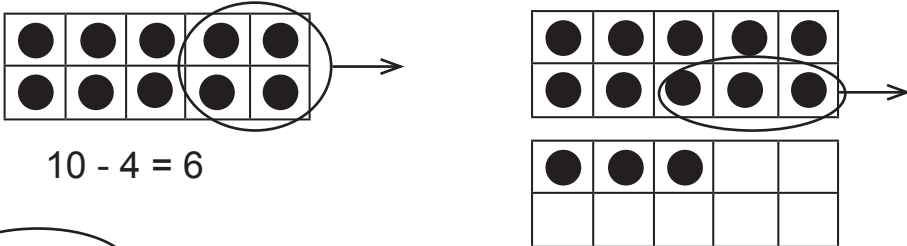
Example:   $10 - 4 = 6$

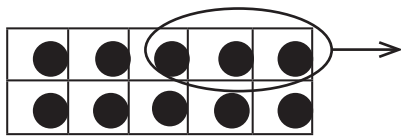

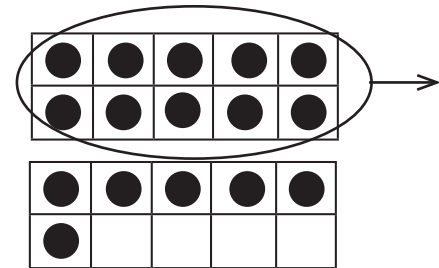

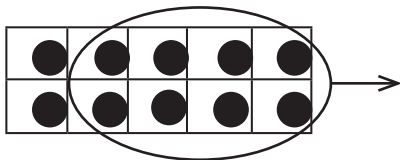

Teacher's Remark(s):

Teacher's Signature and Date:

Find the following **sum**. Show how you solved each problem.

1)  $5 + 2 + 3 =$

2)  $5 + 5 + 8 =$

3)  $7 + 5 + 5 =$

4)  $2 + 7 + 8 =$

5)  $6 + 8 + 4 =$

6)  $7 + 6 + 3 =$

7)  $9 + 9 + 1 + 1 =$

8)  $5 + 4 + 1 =$

---

Teacher's Remark(s):

---

Teacher's Signature and Date:

Use various strategies to add  $8 + 6$ , as suggested below. Show your workings.

1) Use a number line to add  $8 + 6$ .

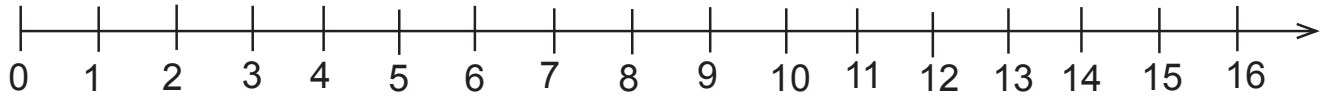

2) Use the **double fact for 6** to add  $8 + 6$ .

3) Use the **double fact for 8** to add  $8 + 6$ .

4) Use a **fact for 10** to add  $8 + 6$ .

---

Teacher's Remark(s):

---

Teacher's Signature and Date:



Solve the following subtraction problems by comparing. Write the subtraction sentence for each. Show your workings.

- 1) Karma drew 11 rectangles and 7 triangles. How many more rectangles did Karma draw than triangles?

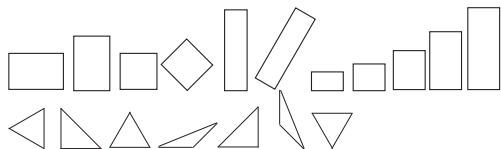

- 2) There are 16 red cubes and 10 blue cubes in a bag. How many more red cubes than blue cubes are there?

- 3) A pen costs Nu 10 and a pencil costs Nu 3. How much more does the pen cost than the pencil?

- 4) There are 12 horses and 6 foals in a field. How many more horses than foals are there? (A baby horse is called a foal.)

- 5) There are 2 cats and 6 kittens in a house. How many more kittens than cats are there? (A baby cat is called a kitten.)

---

Teacher's Remark(s):

---

Teacher's Signature and Date:

Determine the missing number in each of the open addition sentences.

$4 + \underline{\quad} = 10$

$\underline{\quad} + 8 = 12$

$4 + \underline{\quad} = 9$

$\underline{\quad} + 8 = 18$

$8 + \underline{\quad} = 10$

$\underline{\quad} + 6 = 12$

$15 + \underline{\quad} = 20$

$\underline{\quad} + 4 = 10$

$15 + \underline{\quad} = 16$

$\underline{\quad} + 10 = 11$

Represent each story by an open addition sentence. Then, determine the missing number in the sentences.

- 1) 6 birds were sitting on a branch. Some more birds joined them, and there are 10 birds now. How many birds joined later?

- 2) Some rats were eating cheese in a kitchen. 3 more rats joined them, and there are 8 of them now. How many rats were there in the beginning?

Determine the missing number in each of the following open sentences.

$10 = 7 + \underline{\quad}$

$12 = \underline{\quad} + 10$

$14 = \underline{\quad} + 4$

---

Teacher's Remark(s):

---

Teacher's Signature and Date:

Determine the missing number in each of the open subtraction sentences.

$10 - \underline{\quad} = 5$

$9 - \underline{\quad} = 8$

$10 - \underline{\quad} = 9$

$9 - \underline{\quad} = 6$

$12 - \underline{\quad} = 10$

$11 - \underline{\quad} = 6$

$12 - \underline{\quad} = 6$

$7 - \underline{\quad} = 6$

$13 - \underline{\quad} = 10$

$7 - \underline{\quad} = 7$

$15 - \underline{\quad} = 10$

$20 - \underline{\quad} = 15$

$18 - \underline{\quad} = 9$

$20 - \underline{\quad} = 19$

Represent each story by an open subtraction sentence. Then, determine the missing number in the sentences.

- 1) Kelzang had 12 chocolates. He ate some of them, and now he has 8 chocolates left. How many chocolates did he eat?
  
  
  
  
  
  
  
  
  
  
- 2) There are some birds on a roof. 7 of the birds are crows and the rest are pigeons. There are 2 more crows than the pigeons. How many pigeons are there?

---

Teacher's Remark(s):

---

Teacher's Signature and Date:

Solve the following addition and subtraction problems.

$9 + \underline{\quad} = 10$

$13 - \underline{\quad} = 10$

$10 + \underline{\quad} = 15$

$10 - \underline{\quad} = 2$

$\underline{\quad} + 3 = 11$

$\underline{\quad} - 1 = 7$

$\underline{\quad} + 10 = 16$

$\underline{\quad} - 2 = 8$

$12 = 8 + \underline{\quad}$

$1 = \underline{\quad} - 7$

$14 = 7 + \underline{\quad}$

$2 = \underline{\quad} - 4$

$20 = \underline{\quad} + 18$

$8 = 16 - \underline{\quad}$

Represent each story by an addition or a subtraction sentence.

1) There are 8 cubes in a bag. 6 of the cubes are red and the rest are green.

2) Sita has a collection of 10 ornamental items. 2 of the items are earrings and rest are bangles, brooches, finger rings and hair clips.

---

Teacher's Remark(s):

Teacher's Signature and Date:

---

Write down all the addition and subtraction sentences related to the given addition or subtraction sentence.

Example:

1)  $2 + 3 = 5$

$$\underline{3} + \underline{2} = \underline{5}$$

$$\underline{5} - \underline{2} = \underline{3}$$

$$\underline{5} - \underline{3} = \underline{2}$$

4)  $12 - 4 = 8$

$$\underline{\quad} - \underline{\quad} = \underline{\quad}$$

$$\underline{\quad} + \underline{\quad} = \underline{\quad}$$

$$\underline{\quad} + \underline{\quad} = \underline{\quad}$$

2)  $6 + 7 = 13$

$$\underline{\quad} + \underline{\quad} = \underline{\quad}$$

$$\underline{\quad} - \underline{\quad} = \underline{\quad}$$

$$\underline{\quad} - \underline{\quad} = \underline{\quad}$$

5)  $15 - 5 = 10$

$$\underline{\quad} - \underline{\quad} = \underline{\quad}$$

$$\underline{\quad} + \underline{\quad} = \underline{\quad}$$

$$\underline{\quad} + \underline{\quad} = \underline{\quad}$$

3)  $5 + 5 = 10$

$$\underline{\quad} - \underline{\quad} = \underline{\quad}$$

6)  $14 - 7 = 7$

$$\underline{\quad} + \underline{\quad} = \underline{\quad}$$

---

Teacher's Remark(s):

---

Teacher's Signature and Date:

Complete the addition table.

+	0	1	2	3	4	5	6	7	8	9
0										9
1										
2						7				
3										
4										
5		6			9					
6								13		
7										
8				11						
9										18

Refer to the addition table above, and solve the following problems.

$8 + 9 = \underline{\quad}$

$18 - 9 = \underline{\quad}$

$8 + 5 = \underline{\quad}$

$13 - 7 = \underline{\quad}$

$7 + 6 = \underline{\quad}$

$15 - 8 = \underline{\quad}$

$0 + 5 = \underline{\quad}$

$9 - 7 = \underline{\quad}$





$3 + 9 = \underline{\quad}$

$8 - 5 = \underline{\quad}$

Teacher's Remark(s):

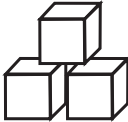
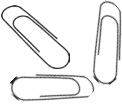
Teacher's Signature and Date:

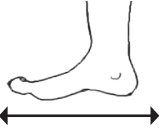
Estimate the following lengths in terms of the paper clips and snap cubes provided to you, and record your estimates. Then, measure the lengths with the paper clips and the snap cubes, and record your measurements.

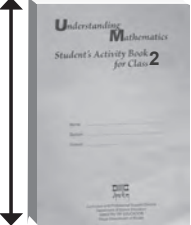
Length	Length using snap cubes 	Length using paper clips 
My hand span 	My estimate: _____ Measurement: _____	My estimate: _____ Measurement: _____
My foot 	My estimate: _____ Measurement: _____	My estimate: _____ Measurement: _____
Distance around my wrist 	My estimate: _____ Measurement: _____	My estimate: _____ Measurement: _____
My pencil 	My estimate: _____ Measurement: _____	My estimate: _____ Measurement: _____
My Activity Book 	My estimate: _____ Measurement: _____	My estimate: _____ Measurement: _____

Teacher's Remark(s): \_\_\_\_\_

Teacher's Signature and Date: \_\_\_\_\_

Use rulers to draw the lines of the lengths specified in centimetres.

1 centimetre	4 centimetre
2 centimetre	5 centimetre
3 centimetre	10 centimetre

Use rulers to measure the lengths of the lines in centimetres, and record them under the lines.

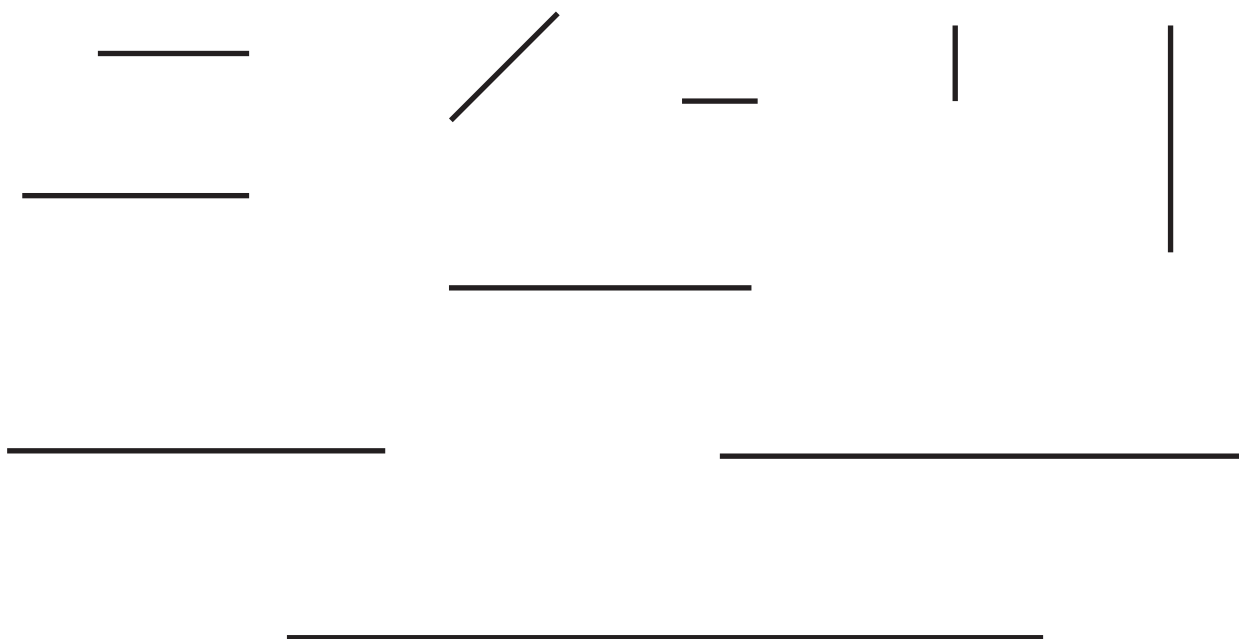

Teacher's Remark(s):

Teacher's Signature and Date:



Use rulers to measure the **perimeters** of the following shapes.



Perimeter: \_\_\_\_ cm

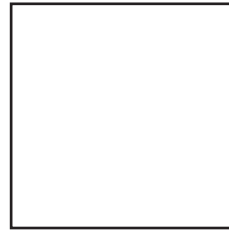

Perimeter: \_\_\_\_ cm

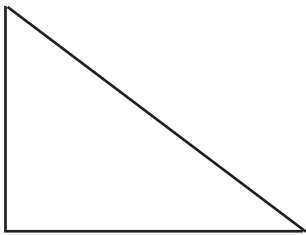

Perimeter: \_\_\_\_ cm



Perimeter: \_\_\_\_ cm

Draw a shape that has a perimeter of 10 cm.

---

Teacher's Remark(s):

Teacher's Signature and Date:

Answer the questions based on the diagram.

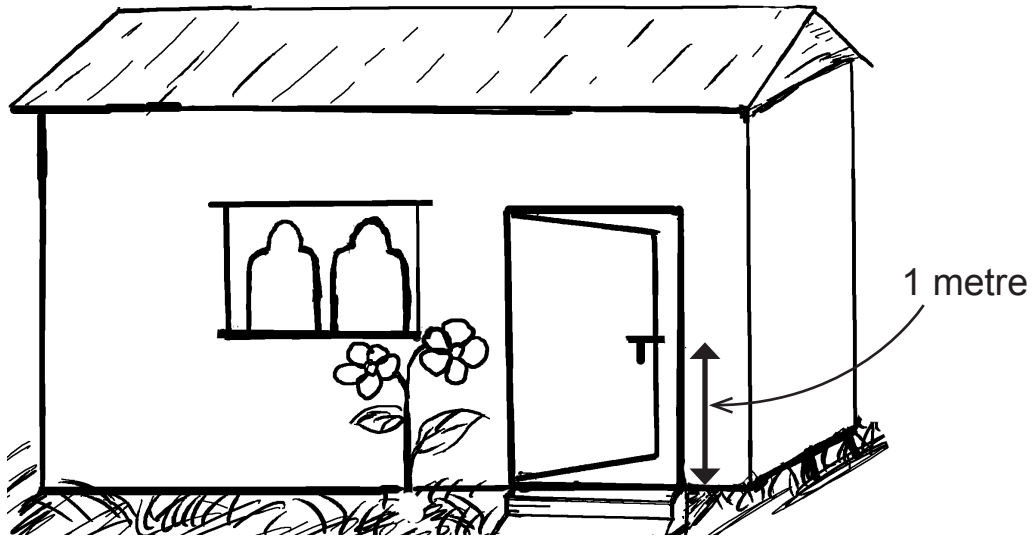

1. What would be the height of the door?

---

2. What would be the height of the windows?

---

3. What would be the height of the flower?

---

4. Is the flower taller than you? Why or why not?

---

5. Are you more than 1 metre tall?

---

6. Would you be more than 2 metres tall?

---

Teacher's Remark(s):

Teacher's Signature and Date:

Look at the following shapes to compare their **areas**, and answer the questions.

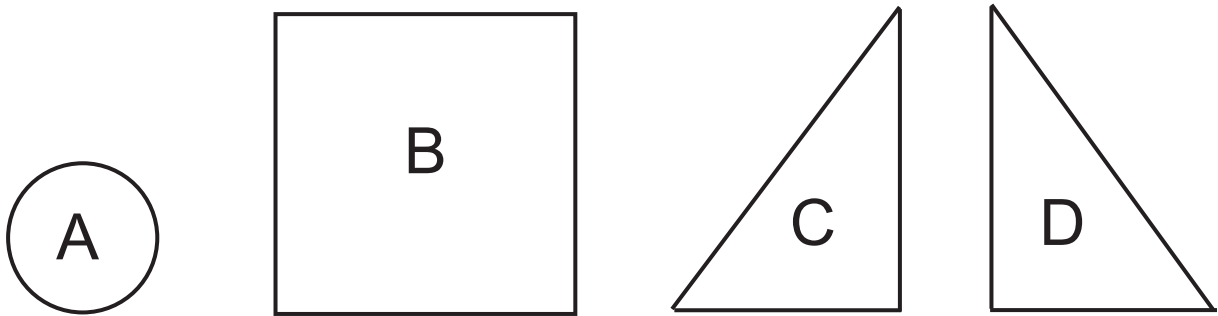

1. Complete the following sentences by writing the words, “**more**”, “**less**”, or “**the same**” in them appropriately.

Shape B has \_\_\_\_\_ area than shape A.

Shape A has \_\_\_\_\_ area than shape B.

Shape C has \_\_\_\_\_ area than shape B.

Shape C has \_\_\_\_\_ area as shape D.

2. Which shape has the largest area?

\_\_\_\_\_

3. Which shape has the smallest area?

\_\_\_\_\_

Teacher's Remark(s): \_\_\_\_\_

Teacher's Signature and Date: \_\_\_\_\_

Use your pattern blocks to measure the areas of the following shapes, and express the areas in terms of the blocks used as indicated in the sentences.

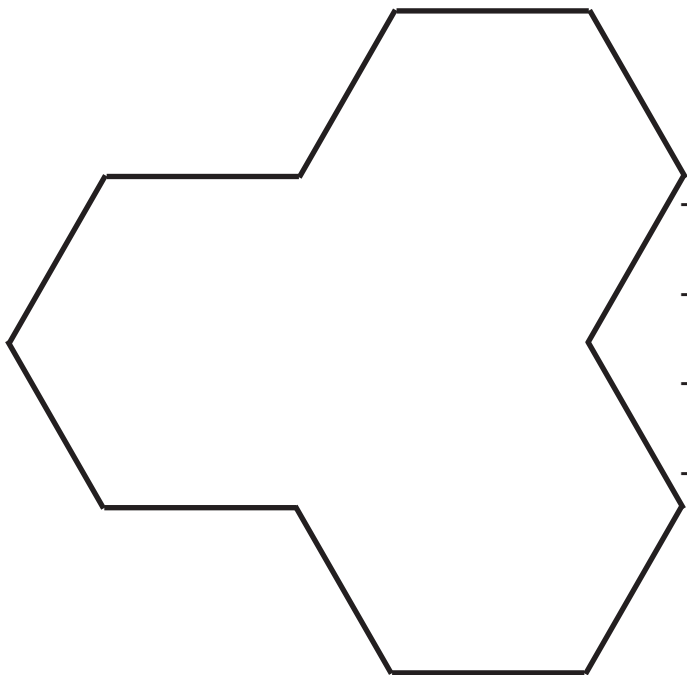
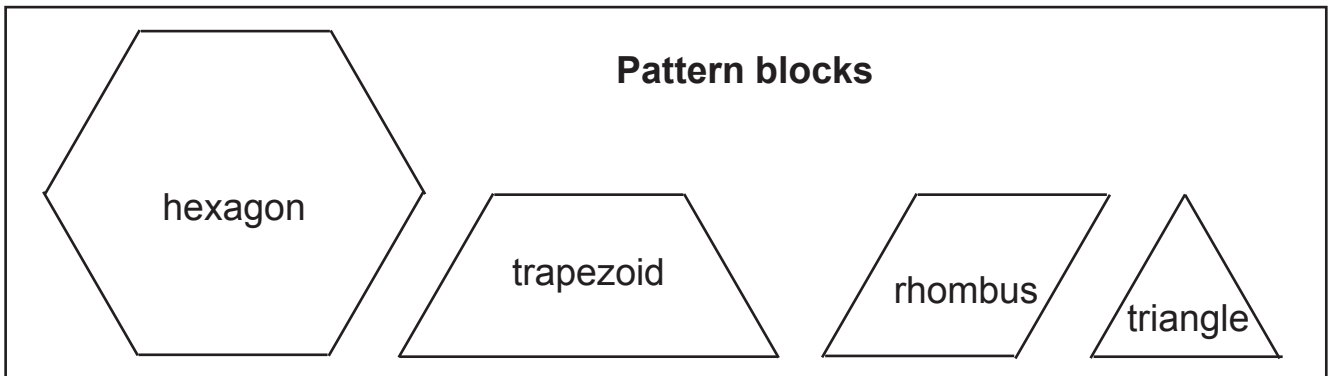

The area of this shape is \_\_\_ hexagons.

The area of this shape is \_\_\_ trapezoids.

The area of this shape is \_\_\_ rhombuses.

The area of this shape is \_\_\_ triangles.



The area of this shape is \_\_\_ trapezoids.

The area of this shape is \_\_\_ rhombuses.

The area of this shape is \_\_\_ triangles.

Teacher's Remark(s):

Teacher's Signature and Date:

Look at the 100-chart and complete the sentences.

**100-chart**

1	2	3	4	5	6	7	8	9	10
11	12	13	14	15	16	17	18	19	20
21	22	23	24	25	26	27	28	29	30
31	32	33	34	35	36	37	38	39	40
41	42	43	44	45	46	47	48	49	50
51	52	53	54	55	56	57	58	59	60
61	62	63	64	65	66	67	68	69	70
71	72	73	74	75	76	77	78	79	80
81	82	83	84	85	86	87	88	89	90
91	92	93	94	95	96	97	98	99	100

Example: 36 is 3 tens and 6 ones.

26 is \_\_\_\_\_ tens and \_\_\_\_\_ ones.

11 is \_\_\_\_\_ tens and \_\_\_\_\_ ones.

76 is \_\_\_\_\_ tens and \_\_\_\_\_ ones.

10 is \_\_\_\_\_ tens and \_\_\_\_\_ ones.

62 is \_\_\_\_\_ tens and \_\_\_\_\_ ones.

20 is \_\_\_\_\_ tens and \_\_\_\_\_ ones.

93 is \_\_\_\_\_ tens and \_\_\_\_\_ ones.

71 is \_\_\_\_\_ tens and \_\_\_\_\_ ones.

29 is \_\_\_\_\_ tens and \_\_\_\_\_ ones.

61 is \_\_\_\_\_ tens and \_\_\_\_\_ ones.

30 is \_\_\_\_\_ tens and \_\_\_\_\_ ones.

16 is \_\_\_\_\_ tens and \_\_\_\_\_ ones.

44 is \_\_\_\_\_ tens and \_\_\_\_\_ ones.

100 is \_\_\_\_\_ tens and \_\_\_\_\_ ones.

55 is \_\_\_\_\_ tens and \_\_\_\_\_ ones.

64 is \_\_\_\_\_ tens and \_\_\_\_\_ ones.

13 is \_\_\_\_\_ tens and \_\_\_\_\_ ones.

---

Teacher's Remark(s):

---

Teacher's Signature and Date:

What number is represented by each set of base ten blocks or the pencils?

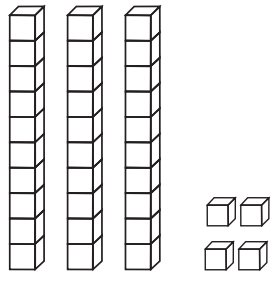
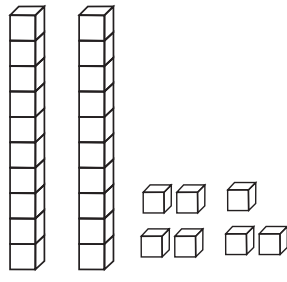
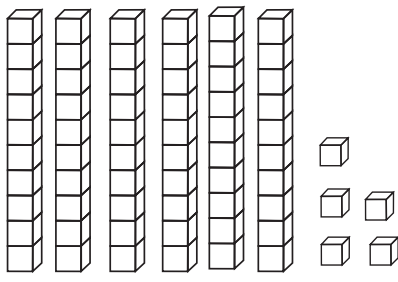
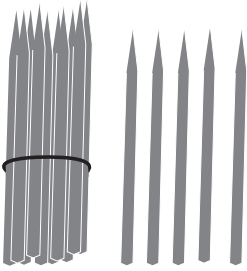
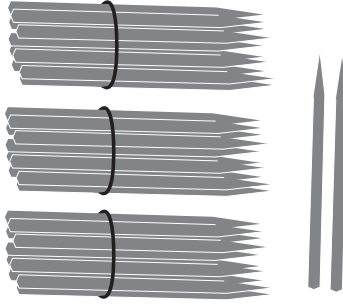
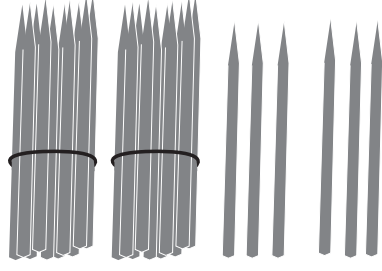





<p>Example:</p>  <p>34</p>	 <p>_____</p>	 <p>_____</p>
 <p>_____</p>	 <p>_____</p>	 <p>_____</p>

<p>Represent 12 by drawing base ten blocks.</p>	<p>Represent 12 by drawing a bundle of pencils and loose pencils.</p>
---	---

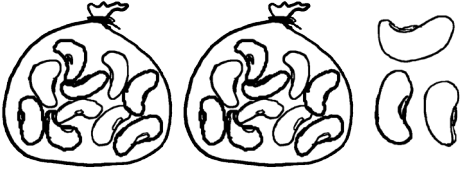
Teacher's Remark(s):

Teacher's Signature and Date:

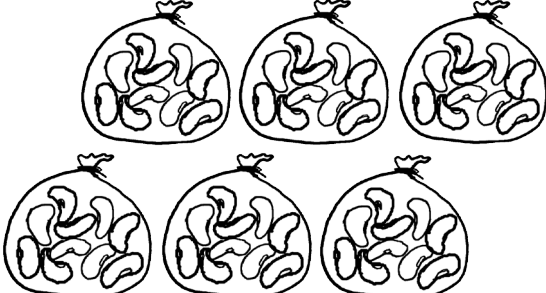
Each bag of bean seeds is a 10. Each individual bean seed is a 1. What number is represented by each set of diagrams?

<p>Example:</p>  <p>23</p>	 <p>_____</p>
 <p>_____</p>	 <p>_____</p>
 <p>_____</p>	 <p>_____</p>

Represent 13 by drawing a bag of bean seeds and loose bean seeds.

Teacher's Remark(s):

Teacher's Signature and Date:

Use the base ten blocks provided by your teacher to measure the lengths of various objects. Express the lengths as tens and ones, as indicated in the table below.

**Base Ten Blocks**

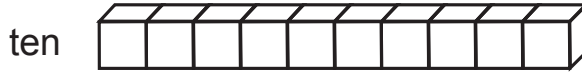

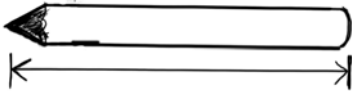
The length we measured (Draw picture and name the object)	How long is that?		
	How many <b>tens</b> long?	And how many <b>ones</b> long?	How many <b>ones</b> long is that?
Example:  Pencil	1	3	13

Teacher's Remark(s):

Teacher's Signature and Date:



Write the given numbers in the place value tables.

Example:

46

Tens	Ones
4	6

35

Tens	Ones

61

Tens	Ones

60

Tens	Ones

17

Tens	Ones

88

Tens	Ones

12

Tens	Ones

50

Tens	Ones

5

Tens	Ones

In the number 26, how many tens are there? How many ones are there?

---

Teacher's Remark(s):

Teacher's Signature and Date:

Write the **sum** for the following additions.

$10 + 10 = \underline{\quad}$

$25 + 10 = \underline{\quad}$

$20 + 20 = \underline{\quad}$

$20 + 10 = \underline{\quad}$

$35 + 10 = \underline{\quad}$

$30 + 20 = \underline{\quad}$

$30 + 10 = \underline{\quad}$

$45 + 10 = \underline{\quad}$

$40 + 20 = \underline{\quad}$

$40 + 10 = \underline{\quad}$

$55 + 10 = \underline{\quad}$

$50 + 20 = \underline{\quad}$

$50 + 10 = \underline{\quad}$

$65 + 10 = \underline{\quad}$

$60 + 20 = \underline{\quad}$

$60 + 10 = \underline{\quad}$

$75 + 10 = \underline{\quad}$

$80 + 20 = \underline{\quad}$

$70 + 10 = \underline{\quad}$

$85 + 10 = \underline{\quad}$

$80 + 10 = \underline{\quad}$

$90 + 10 = \underline{\quad}$

---

Teacher's Remark(s):

---

Teacher's Signature and Date:

Write the fraction names for each of the fraction numbers, which represents the shaded parts of each shape.

Example:



$$\frac{1}{2}$$

one-half



$$\frac{1}{3}$$

\_\_\_\_\_



$$\frac{2}{3}$$

\_\_\_\_\_

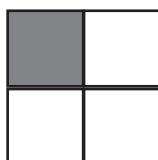

$$\frac{1}{4}$$

\_\_\_\_\_



$$\frac{3}{4}$$

\_\_\_\_\_

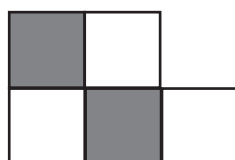

$$\frac{2}{5}$$

\_\_\_\_\_



$$\frac{5}{6}$$

\_\_\_\_\_

---

Teacher's Remark(s):

Teacher's Signature and Date:

Write the fraction number for the shaded parts of each shape.

Example:

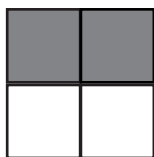

$$\frac{2}{4}$$



\_\_\_\_\_



\_\_\_\_\_

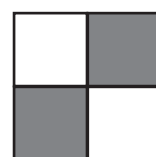

\_\_\_\_\_



\_\_\_\_\_



\_\_\_\_\_

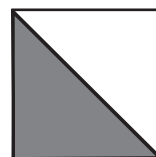

\_\_\_\_\_

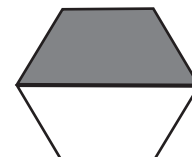

\_\_\_\_\_



\_\_\_\_\_



\_\_\_\_\_



\_\_\_\_\_



\_\_\_\_\_



\_\_\_\_\_

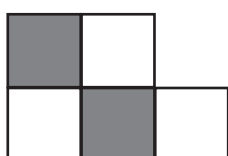

\_\_\_\_\_



\_\_\_\_\_

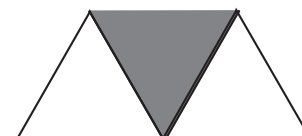

\_\_\_\_\_

Teacher's Remark(s):

Teacher's Signature and Date:

Shade the parts of the shapes to represent the fractions written below them.

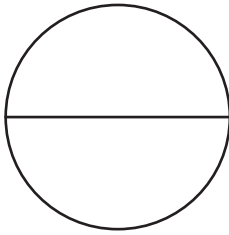

$$\frac{1}{2}$$

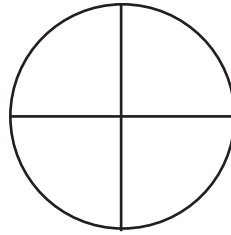

$$\frac{1}{4}$$

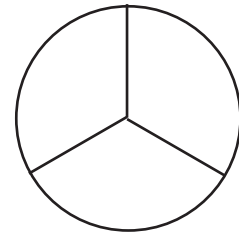

$$\frac{2}{3}$$

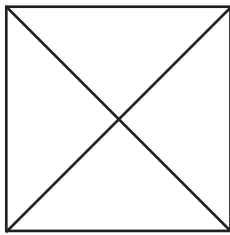

$$\frac{2}{4}$$

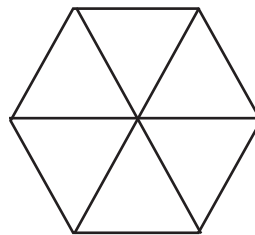

$$\frac{1}{6}$$

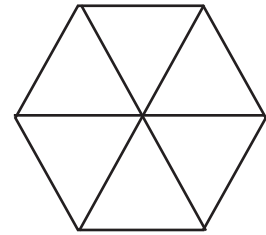

$$\frac{5}{6}$$

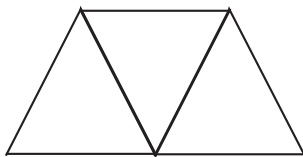

$$\frac{2}{3}$$

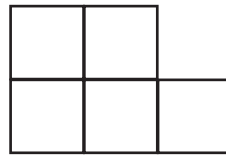

$$\frac{2}{5}$$

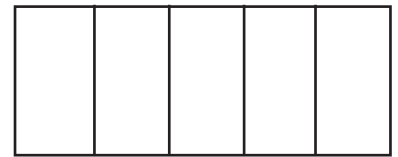

$$\frac{4}{5}$$

The fraction  $\frac{2}{3}$  represents the shaded parts of the shape below. Write a fraction to represent the unshaded part of the shape.



shaded part:  $\frac{2}{3}$

unshaded part: \_\_\_\_\_

Teacher's Remark(s): \_\_\_\_\_

Teacher's Signature and Date: \_\_\_\_\_

Look at the pairs of shapes. The larger shape in a pair represents 1 whole shape and the smaller shape is a fraction of the larger shape. Write the fraction number for the smaller shape.

Example:

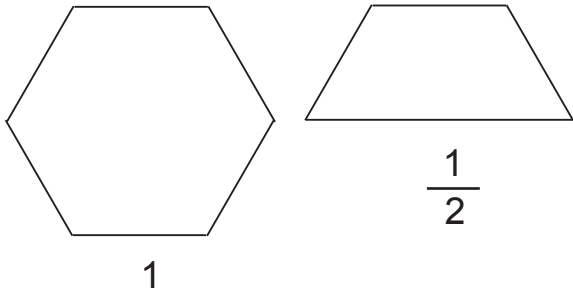

1  $\frac{1}{2}$

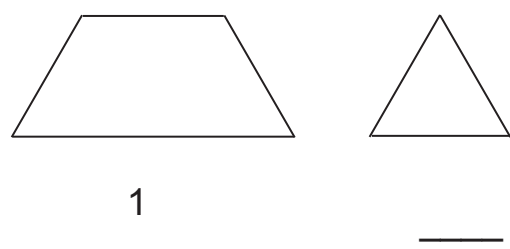

1 \_\_\_\_\_

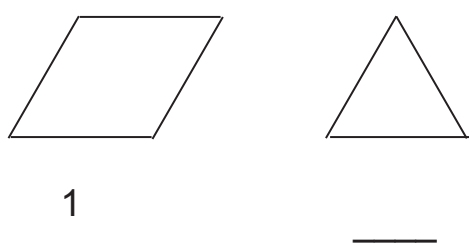

1 \_\_\_\_\_

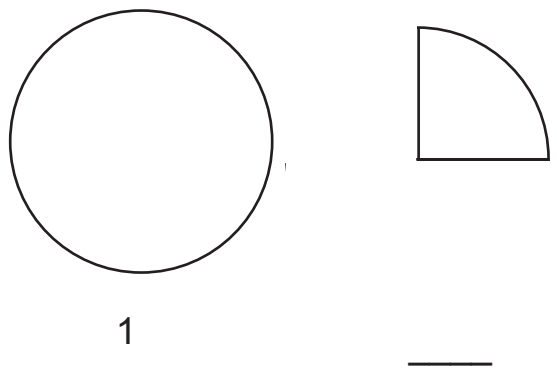

1 \_\_\_\_\_

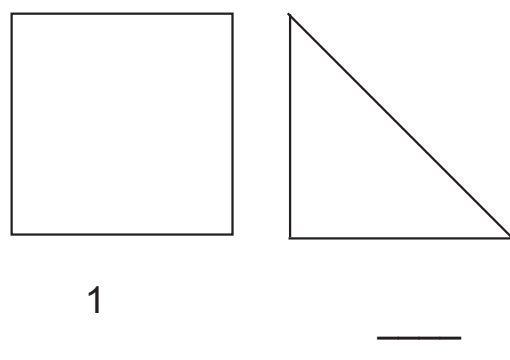

1 \_\_\_\_\_

Teacher's Remark(s):

Teacher's Signature and Date:

What fraction of the set is the indicated item in each set? Write the fraction number for it.

Example:

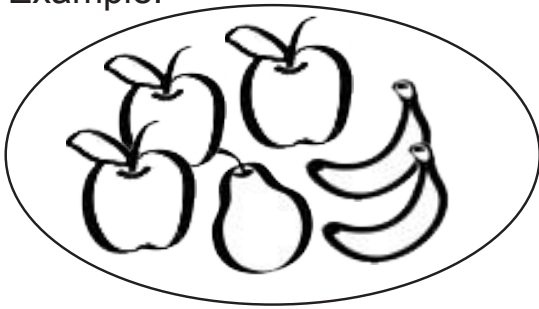

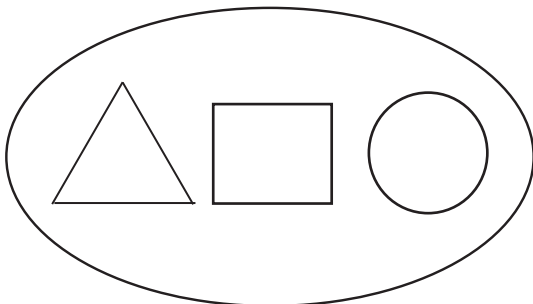
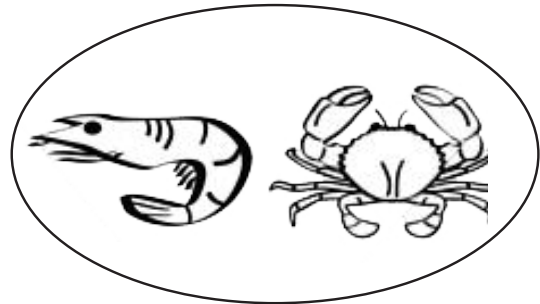
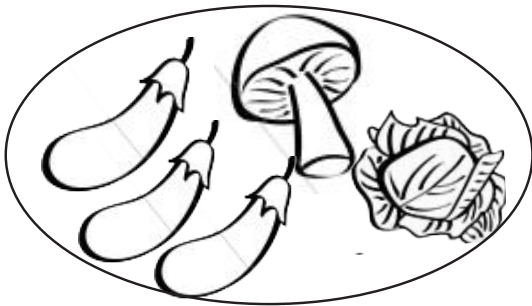
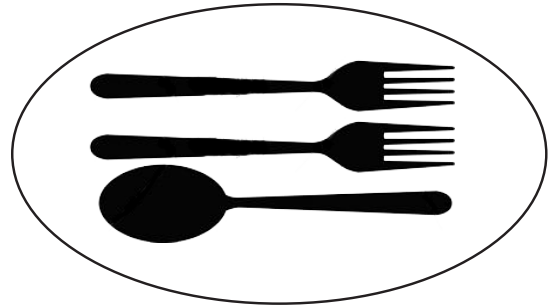

  $\frac{3}{6}$ 
  $\frac{1}{6}$ 
  $\frac{2}{6}$



Teacher's Remark(s):

Teacher's Signature and Date:

Look at the pairs of lines and decide if the pairs are **parallel lines** or **non-parallel lines**. Then, write the phrases, “parallel lines” or “non-parallel lines” below them accordingly.

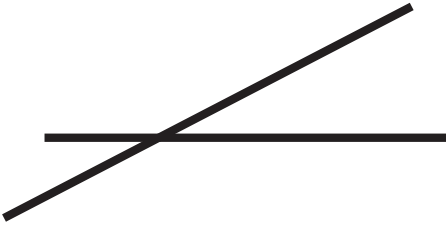
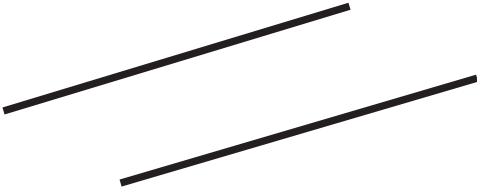
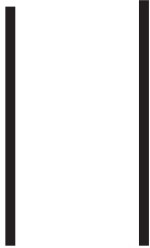
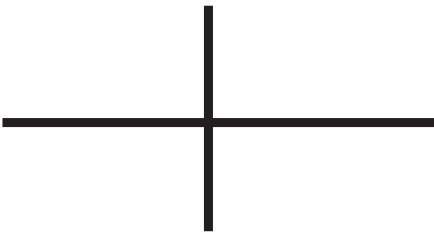

Teacher's Remark(s):

Teacher's Signature and Date:



Cut out the following pairs of lines and sort them into two sets.

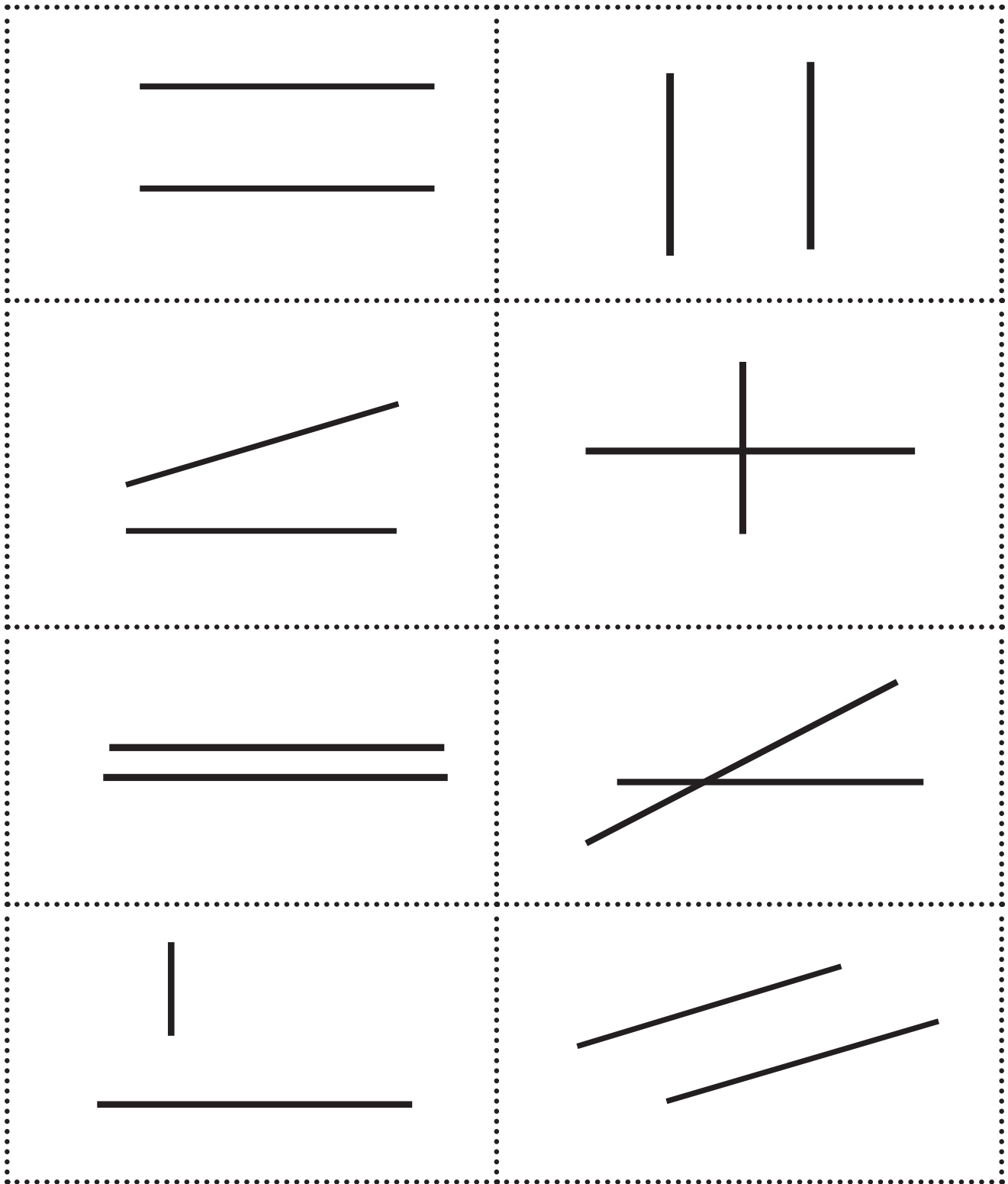

THIS PAGE IS LEFT BLANK

Cut out the following shapes and sort them into symmetrical and non-symmetrical shapes.

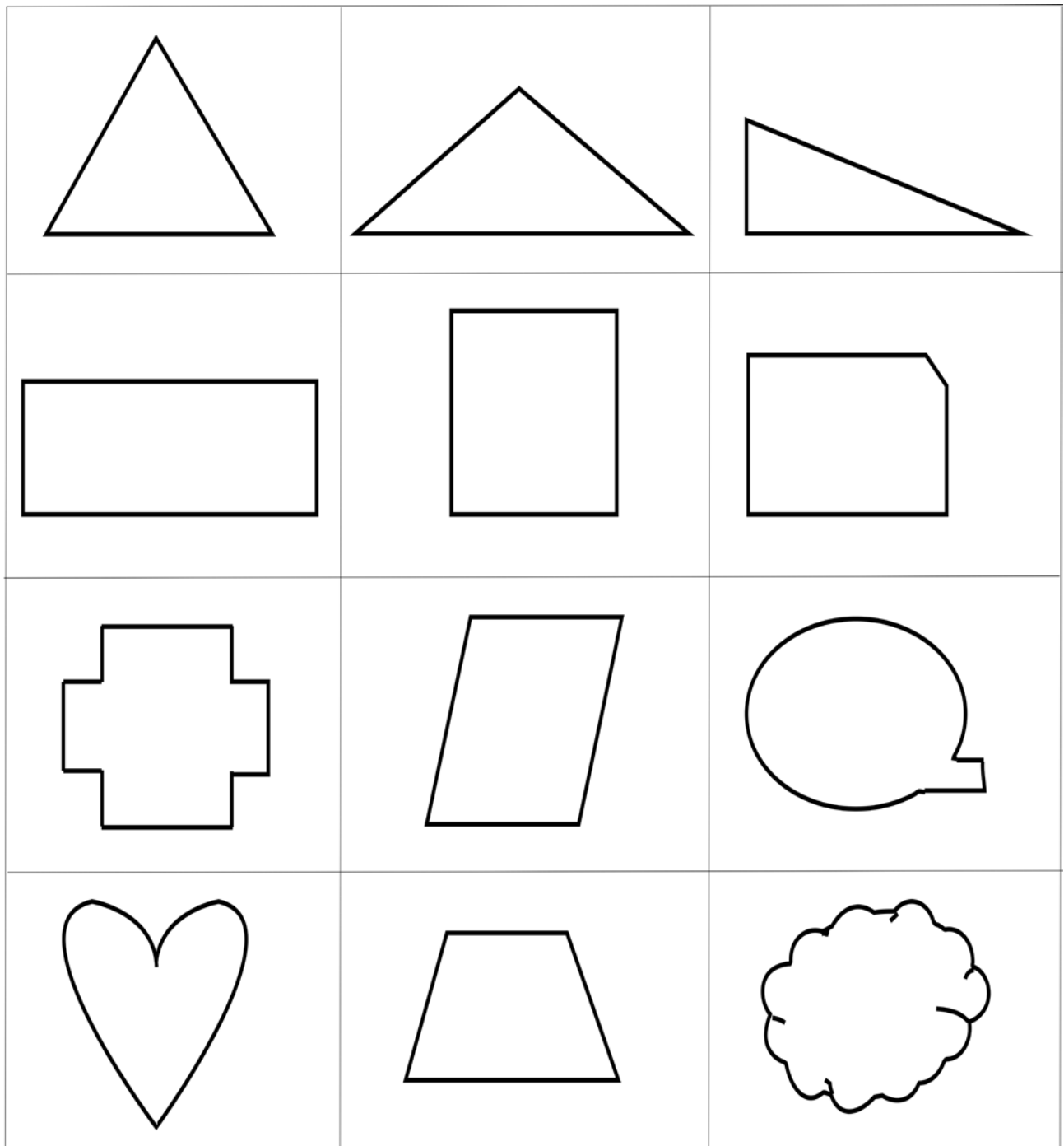

THIS PAGE IS LEFT BLANK

Draw all the lines of symmetry for each shape, and write the number of lines of symmetry below the shapes.



Number of lines of symmetry: \_\_\_\_

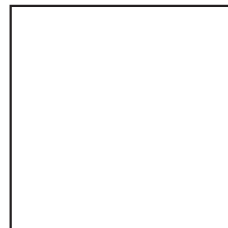

Number of lines of symmetry: \_\_\_\_



Number of lines of symmetry: \_\_\_\_

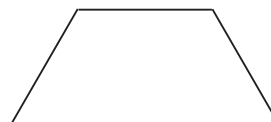

Number of lines of symmetry: \_\_\_\_

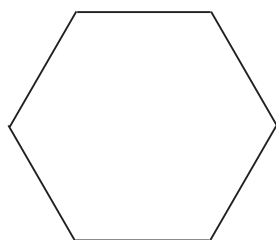

Number of lines of symmetry: \_\_\_\_

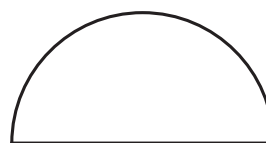







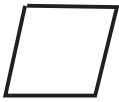

Number of lines of symmetry: \_\_\_\_

Teacher's Remark(s):

Teacher's Signature and Date:

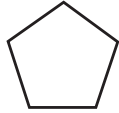
Fill up the table with the required information for each shape below.

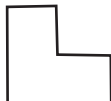
Shapes	Number of sides	Number of corners	Number of pairs of parallel lines	Number of lines of symmetry
This Triangle 				
This Triangle 				
This Rhombus 				
This Rectangle 				
This Rectangle (all sides same) 				
This Trapezoid 				
This Pentagon 				
This Hexagon 				
This Pentagon 				
This Hexagon 				

Teacher's Remark(s):

Teacher's Signature and Date:

Look at the following **rectangles**, and determine which are **squares** and which are not. Write the word “square” under the ones which are squares.

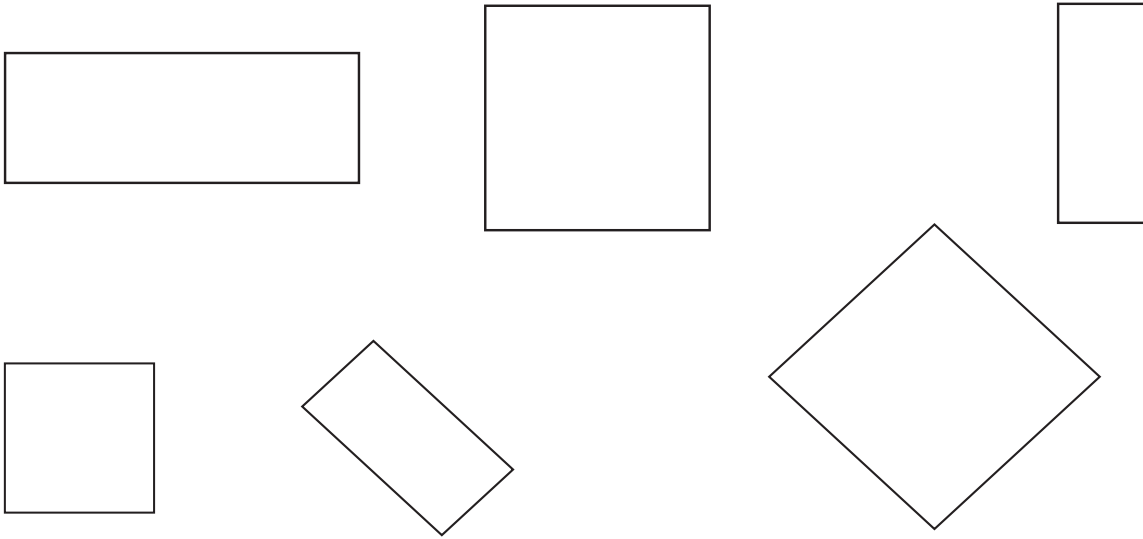

Draw a square.

Draw a rectangle which is not a square.

Write what you know about squares.

Teacher's Remark(s):

Teacher's Signature and Date:

Name the following 3-D shapes as **prism**, **pyramid**, **cone**, **cylinder** or **sphere**.

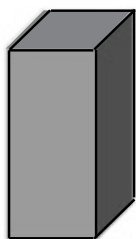

\_\_\_\_\_

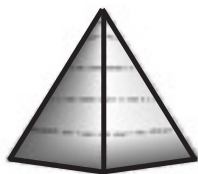

\_\_\_\_\_



\_\_\_\_\_

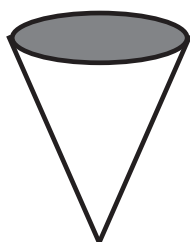

\_\_\_\_\_

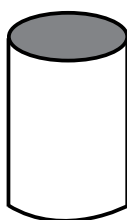

\_\_\_\_\_

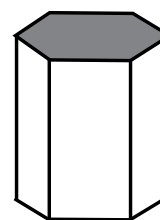

\_\_\_\_\_



\_\_\_\_\_

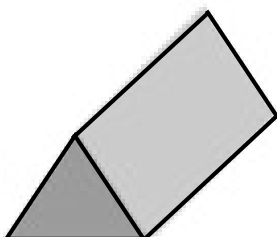

\_\_\_\_\_

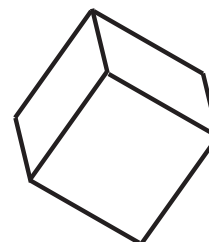

\_\_\_\_\_

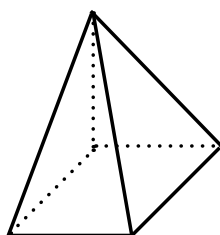

\_\_\_\_\_

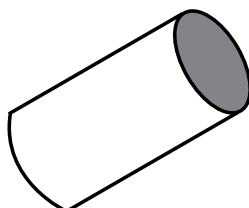

\_\_\_\_\_

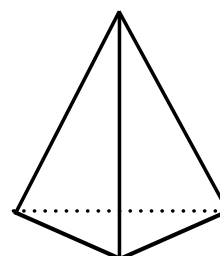

\_\_\_\_\_

Teacher's Remark(s):

Teacher's Signature and Date:



Draw a cylinder, and label its base and apex.

Draw a cone, and label its base and apex.

---

Teacher's Remark(s):

Teacher's Signature and Date:

Name the following prisms as **rectangular prism** or **triangular prism**. Label the bases for each prism.

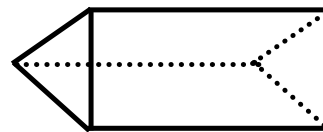
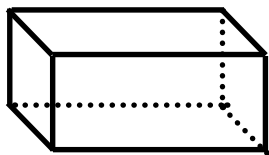

Write what you know about prisms.

Name the following pyramids as **rectangular pyramid** or **triangular pyramid**. Label the **base** and the **apex** for each pyramid.

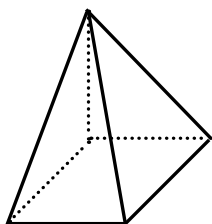

apex

base

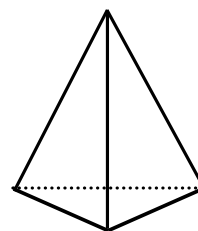

apex

base

Write what you know about pyramids.

Teacher's Remark(s):

Teacher's Signature and Date:

Fill up the table with the required information for each shape below.

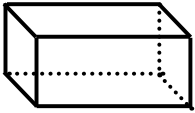
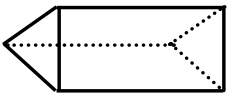
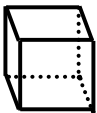
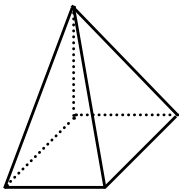
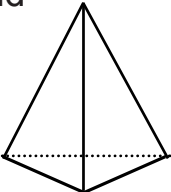
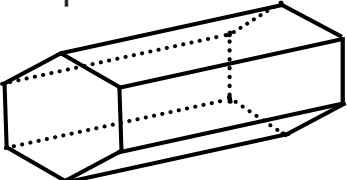
Shapes	Number of corners	Number of edges	Number of rectangular faces	Number of triangular faces
Rectangular prism 				
Triangular prism 				
Cube (Rectangular prism) 				
Rectangular pyramid 				
Triangular pyramid 				
Hexagonal prism 				

Teacher's Remark(s):

Teacher's Signature and Date:

Each shape below is a net for a 3-D shape. Name the 3-D shape for each net.

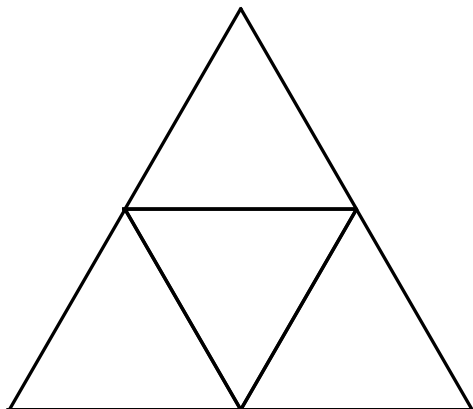

\_\_\_\_\_

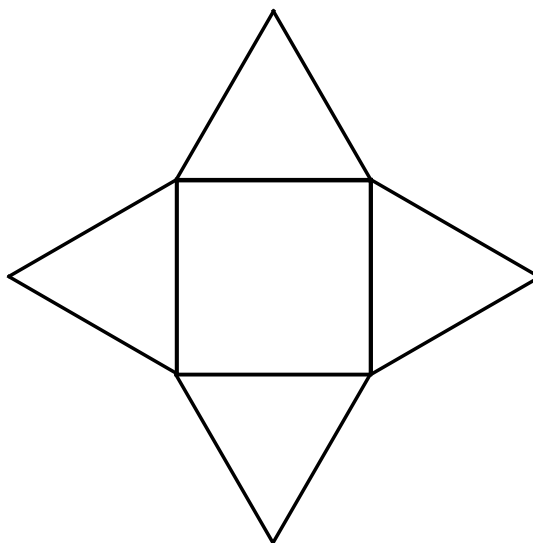

\_\_\_\_\_

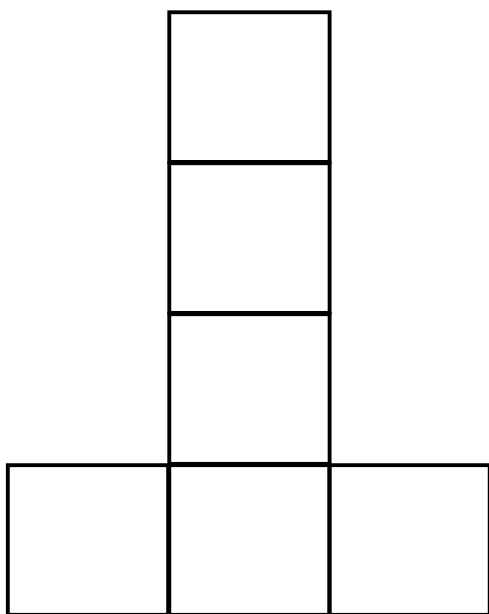

\_\_\_\_\_

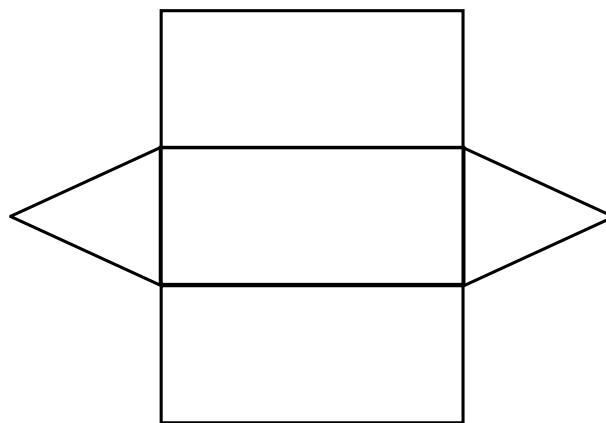

\_\_\_\_\_

Teacher's Remark(s):

Teacher's Signature and Date:

Cut out the following nets to make 3-D shapes. Name the 3-D shape that you get from each of the nets.

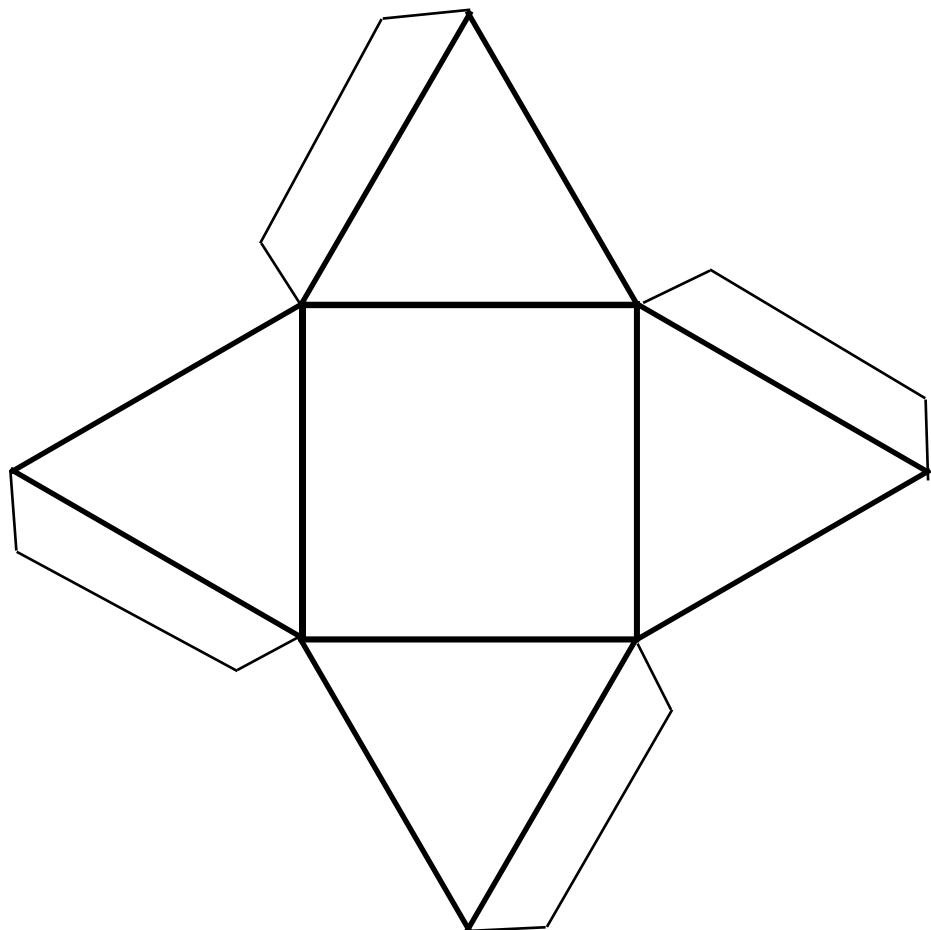
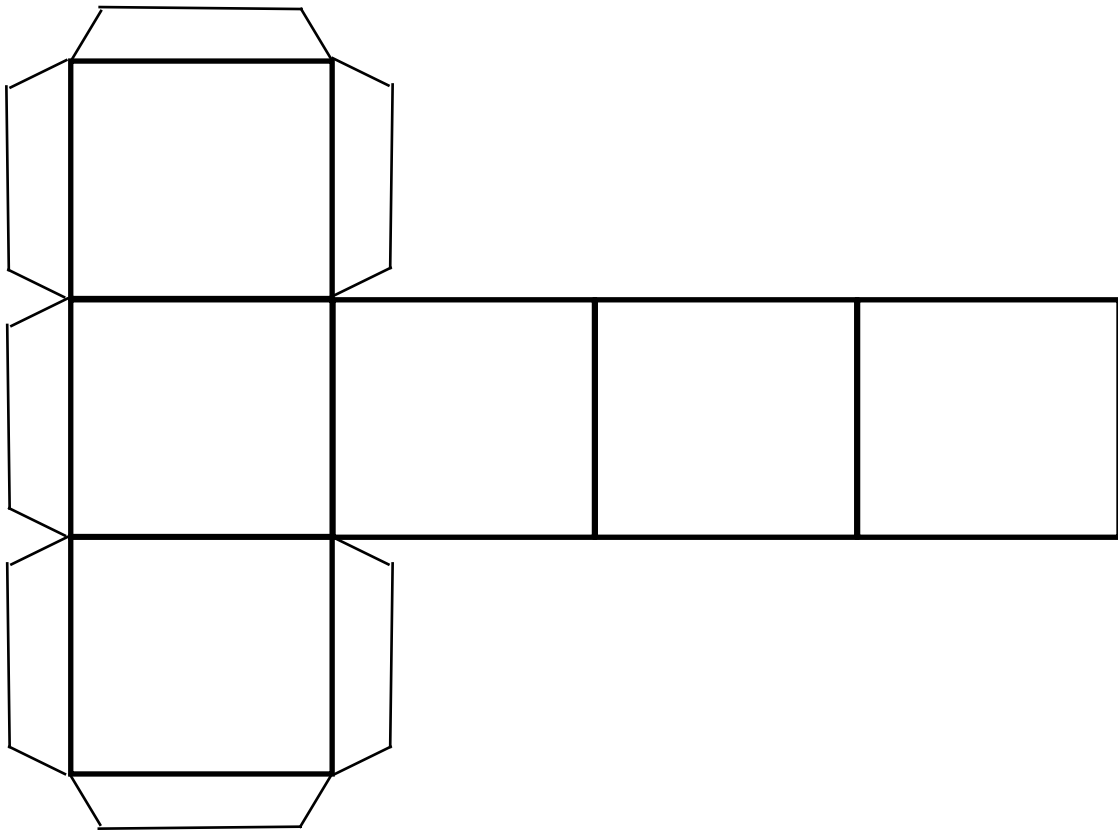

THIS PAGE IS LEFT BLANK

Cut out the following nets to make 3-D shapes. Name the 3-D shape that you get from each of the nets.

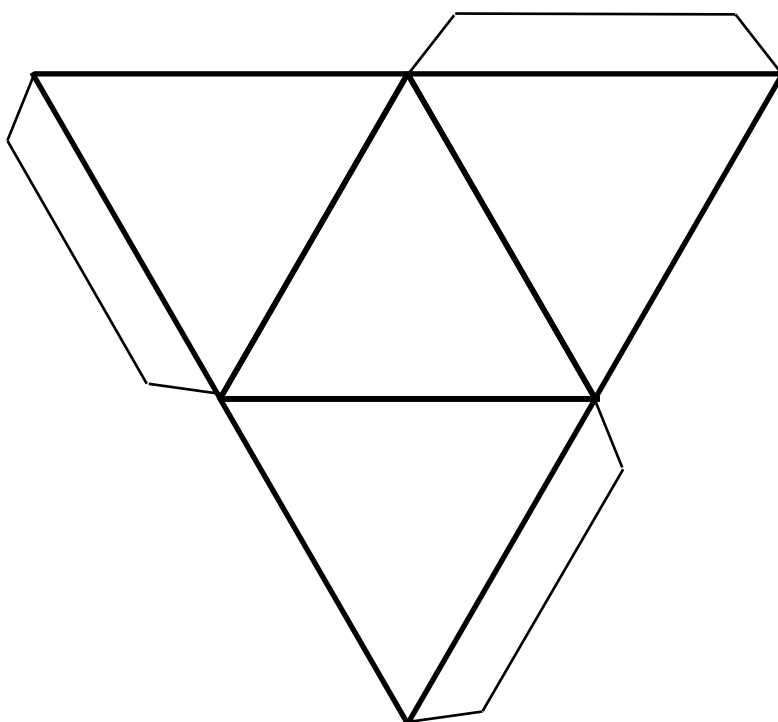
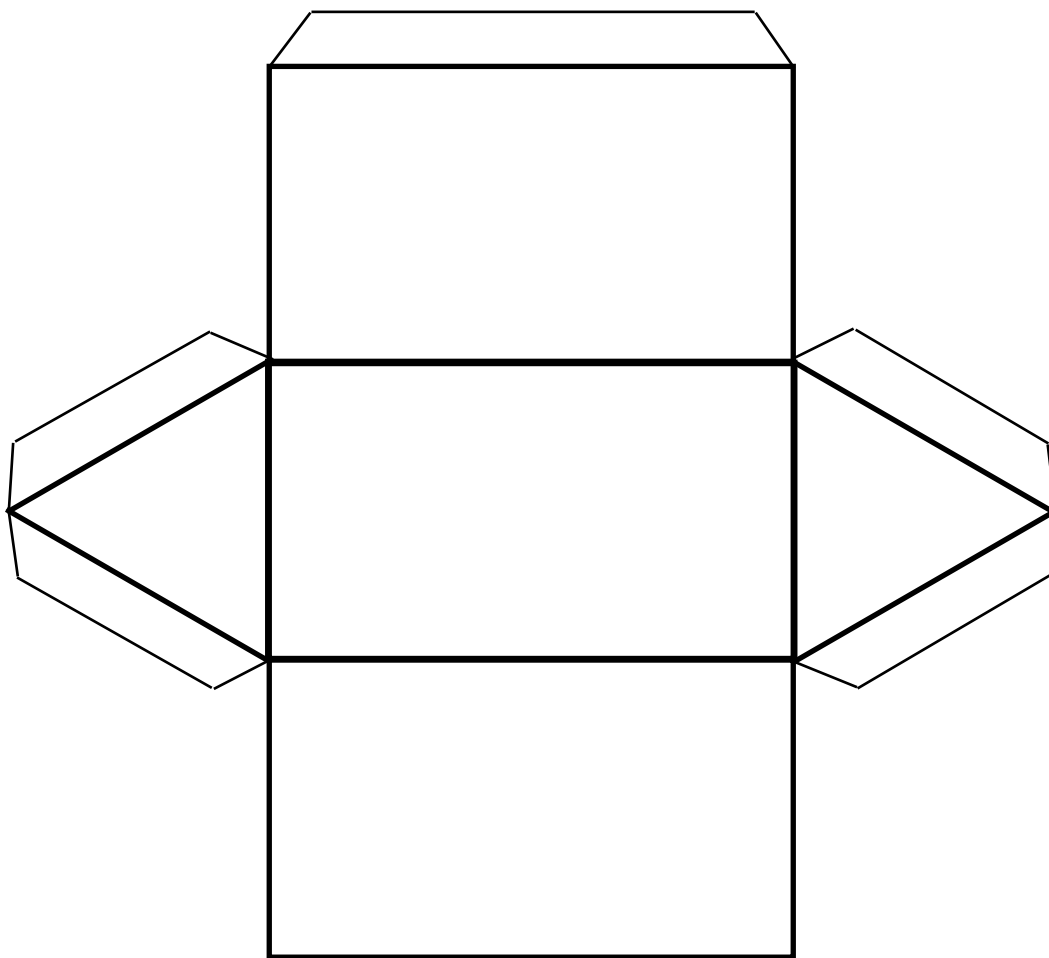

THIS PAGE IS LEFT BLANK



Each of the following diagrams represents 10.

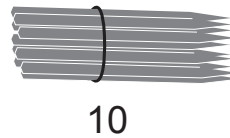
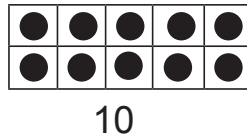
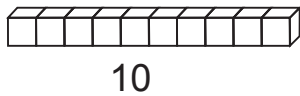

Represent the following sets of diagrams with addition sentences.

<p><b>Example:</b></p> <p style="text-align: center;"><math>30 + 20 = 50</math></p>	<p style="text-align: center;">_____ + _____ = _____</p>
<p style="text-align: center;">_____ + _____ = _____</p>	<p style="text-align: center;">_____ + _____ = _____</p>

Complete the following addition sentences.

3 tens + 2 tens = \_\_\_\_\_ tens

5 tens + 3 tens = \_\_\_\_\_ tens

7 tens + 2 tens = \_\_\_\_\_ tens

3 tens + 3 tens = \_\_\_\_\_ tens

5 tens + 1 ten = \_\_\_\_\_ tens

5 tens + 5 tens = \_\_\_\_\_ tens

30 + 20 = \_\_\_\_\_

50 + 30 = \_\_\_\_\_

70 + 20 = \_\_\_\_\_

20 + 20 = \_\_\_\_\_

50 + 40 = \_\_\_\_\_

30 + 30 = \_\_\_\_\_

42 + 10 = \_\_\_\_\_

36 + 10 = \_\_\_\_\_

42 + 20 = \_\_\_\_\_

36 + 30 = \_\_\_\_\_

Teacher's Remark(s):

Teacher's Signature and Date:

Find the **sum** for the following.

$30 + 10 = \underline{\quad}$

$30 + 20 = \underline{\quad}$

$34 + 10 = \underline{\quad}$

$34 + 20 = \underline{\quad}$

$34 + 22 = \underline{\quad}$

$34 + 25 = \underline{\quad}$

$62 + 22 = \underline{\quad}$

$73 + 15 = \underline{\quad}$

$55 + 33 = \underline{\quad}$

$18 + 31 = \underline{\quad}$

Find the sum for the following.

$39 + 21 = \underline{\quad}$

$63 + 27 = \underline{\quad}$

$39 + 26 = \underline{\quad}$

$56 + 26 = \underline{\quad}$

$56 + 16 = \underline{\quad}$

---

Teacher's Remark(s):

Teacher's Signature and Date:

Use the 100-chart to find the **sum** for the following.

1	2	3	4	5	6	7	8	9	10
11	12	13	14	15	16	17	18	19	20
21	22	23	24	25	26	27	28	29	30
31	32	33	34	35	36	37	38	39	40
41	42	43	44	45	46	47	48	49	50
51	52	53	54	55	56	57	58	59	60
61	62	63	64	65	66	67	68	69	70
71	72	73	74	75	76	77	78	79	80
81	82	83	84	85	86	87	88	89	90
91	92	93	94	95	96	97	98	99	100

$34 + 10 = \underline{\quad}$

$56 + 16 = \underline{\quad}$

$34 + 20 = \underline{\quad}$

$18 + 31 = \underline{\quad}$

$34 + 34 = \underline{\quad}$

$73 + 15 = \underline{\quad}$

$55 + 34 = \underline{\quad}$

$34 + 34 = \underline{\quad}$

$52 + 12 = \underline{\quad}$

$62 + 22 = \underline{\quad}$

$39 + 21 = \underline{\quad}$

$80 + 10 = \underline{\quad}$

$63 + 27 = \underline{\quad}$

$80 + 20 = \underline{\quad}$

---

Teacher's Remark(s):

---

Teacher's Signature and Date:

Find the **sums** by, first, adding the tens and the ones separately, and then, adding the sums of the tens and the ones.

Example:

$$34 + 22 = 50 + 6 = 56$$

$30 + 20$  (adding the tens)       $4 + 2$  (adding the ones)

$$36 + 32 = \underline{\quad} + \underline{\quad} = \underline{\quad}$$

$$36 + 41 = \underline{\quad} + \underline{\quad} = \underline{\quad}$$

$$36 + 24 = \underline{\quad} + \underline{\quad} = \underline{\quad}$$

$$73 + 23 = \underline{\quad} + \underline{\quad} = \underline{\quad}$$

$$63 + 27 = \underline{\quad} + \underline{\quad} = \underline{\quad}$$

$$46 + 24 = \underline{\quad} + \underline{\quad} = \underline{\quad}$$

$$15 + 15 = \underline{\quad} + \underline{\quad} = \underline{\quad}$$

$$16 + 16 = \underline{\quad} + \underline{\quad} = \underline{\quad}$$

$$25 + 25 = \underline{\quad} + \underline{\quad} = \underline{\quad}$$

$$25 + 24 = \underline{\quad} + \underline{\quad} = \underline{\quad}$$

$$39 + 39 = \underline{\quad} + \underline{\quad} = \underline{\quad}$$

$$65 + 10 = \underline{\quad} + \underline{\quad} = \underline{\quad}$$

$$57 + 24 = \underline{\quad} + \underline{\quad} = \underline{\quad}$$

---

Teacher's Remark(s):

Teacher's Signature and Date:

Find the **sums** by, first, adding the tens and the ones separately, and then adding the sums of the tens and the ones.

Example:

$$\begin{array}{r}
 34 \\
 + 22 \\
 \hline
 50 \leftarrow 30 + 20 \text{ (adding the tens)} \\
 \underline{6} \leftarrow 4 + 2 \text{ (adding the ones)} \\
 56
 \end{array}$$

$  \begin{array}{r}  63 \\  + 24 \\  \hline  \end{array}  $	$  \begin{array}{r}  45 \\  + 12 \\  \hline  \end{array}  $	$  \begin{array}{r}  36 \\  + 24 \\  \hline  \end{array}  $
$  \begin{array}{r}  56 \\  + 16 \\  \hline  \end{array}  $	$  \begin{array}{r}  16 \\  + 16 \\  \hline  \end{array}  $	$  \begin{array}{r}  75 \\  + 10 \\  \hline  \end{array}  $
$  \begin{array}{r}  73 \\  + 23 \\  \hline  \end{array}  $	$  \begin{array}{r}  47 \\  + 24 \\  \hline  \end{array}  $	$  \begin{array}{r}  25 \\  + 25 \\  \hline  \end{array}  $

Teacher's Remark(s):

Teacher's Signature and Date:

Find the sums for the following additions using place value tables.

Example 1:  $34 + 22$

Tens	Ones
3	4
+ 2	2
5	6

$$34 + 22 = 56$$

Example 2:  $43 + 29$

Tens	Ones
4	3
+ 2	9
6	12
7	2

10 + 2, or  
1 ten + 2 ones

6 tens + 1 ten is 7 tens

$$43 + 29 = 72$$

Tens	Ones
6	3
+ 3	8

$$63 + 38 = \underline{\quad}$$

Tens	Ones
5	5
+ 1	7

$$55 + 17 = \underline{\quad}$$

Tens	Ones
4	7
+ 4	3

$$47 + 43 = \underline{\quad}$$

Tens	Ones
1	8
+ 3	8

$$18 + 38 = \underline{\quad}$$

Tens	Ones
7	0
+ 1	9

$$70 + 19 = \underline{\quad}$$

Tens	Ones
4	4
+ 2	6

$$44 + 26 = \underline{\quad}$$

Teacher's Remark(s):

Teacher's Signature and Date:

Represent the second set of diagrams with a subtraction sentence.

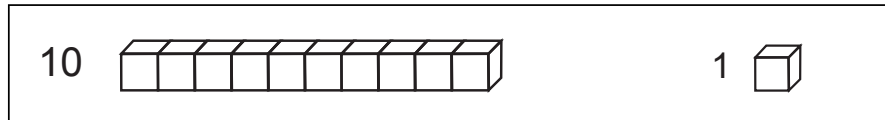

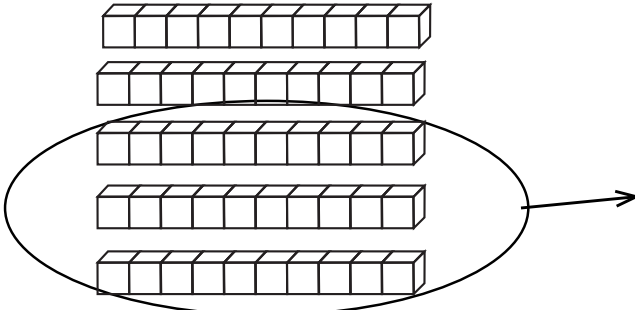
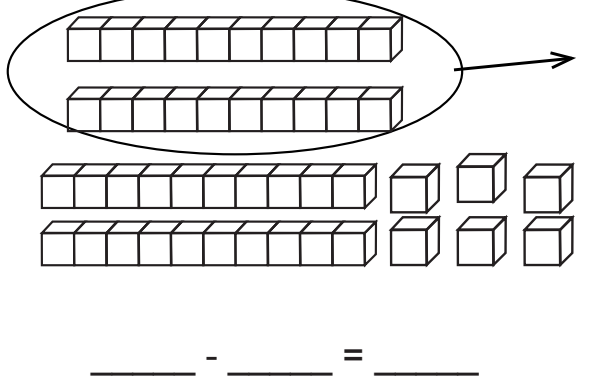
<p><b>Example:</b></p>  <p style="text-align: center;"><math>50 - 30 = 20</math></p>	 <p style="text-align: center;">____ - ____ = ____</p>
---	--

Complete the following subtraction sentences.

$5 \text{ tens} - 3 \text{ tens} = \underline{\quad} \text{ tens}$

$7 \text{ tens} - 3 \text{ tens} = \underline{\quad} \text{ tens}$

$6 \text{ tens} - 3 \text{ tens} = \underline{\quad} \text{ tens}$

$8 \text{ tens} - 7 \text{ tens} = \underline{\quad} \text{ ten}$

$10 \text{ tens} - 7 \text{ tens} = \underline{\quad} \text{ tens}$

$10 \text{ tens} - 3 \text{ tens} = \underline{\quad} \text{ tens}$

$5 \text{ tens} - 5 \text{ tens} = \underline{\quad} \text{ tens}$

$2 \text{ tens} - 1 \text{ tens} = \underline{\quad} \text{ ten}$

$50 - 30 = \underline{\quad}$

$40 - 10 = \underline{\quad}$

$56 - 20 = \underline{\quad}$

$60 - 30 = \underline{\quad}$

$42 - 10 = \underline{\quad}$

$65 - 30 = \underline{\quad}$

$80 - 70 = \underline{\quad}$

$42 - 20 = \underline{\quad}$

$60 - 60 = \underline{\quad}$

$20 - 10 = \underline{\quad}$

$42 - 30 = \underline{\quad}$

$10 - 10 = \underline{\quad}$

Teacher's Remark(s):

Teacher's Signature and Date:

Find the **differences** by, first, subtracting the tens and the ones separately, and, then, adding the differences of the tens and the ones.

Example:  $47 - 23 = (40 - 20) + (7 - 3) = 20 + 4 = 24$

difference of the tens   difference of the ones

$$34 - 22 = ( \quad - \quad ) + ( \quad - \quad ) = \quad + \quad = \quad$$

$$46 - 20 = ( \quad - \quad ) + ( \quad - \quad ) = \quad + \quad = \quad$$

$$46 - 21 = ( \quad - \quad ) + ( \quad - \quad ) = \quad + \quad = \quad$$

$$65 - 55 = ( \quad - \quad ) + ( \quad - \quad ) = \quad + \quad = \quad$$

$$24 - 12 = ( \quad - \quad ) + ( \quad - \quad ) = \quad + \quad = \quad$$

$$47 - 23 = ( \quad - \quad ) + ( \quad - \quad ) = \quad + \quad = \quad$$

$$57 - 55 = ( \quad - \quad ) + ( \quad - \quad ) = \quad + \quad = \quad$$

$$45 - 35 = ( \quad - \quad ) + ( \quad - \quad ) = \quad + \quad = \quad$$

$$97 - 53 = ( \quad - \quad ) + ( \quad - \quad ) = \quad + \quad = \quad$$

$$58 - 26 = ( \quad - \quad ) + ( \quad - \quad ) = \quad + \quad = \quad$$

Teacher's Remark(s): \_\_\_\_\_

Teacher's Signature and Date: \_\_\_\_\_



Find the **differences** by, first, subtracting the tens and the ones separately, and, then, adding the differences of the tens and the ones.

Example:

$$\begin{array}{r} 57 \\ - 23 \\ \hline 30 \\ + 4 \\ \hline 34 \end{array}$$

← 50 - 20 (difference of the tens)

← 7 - 3 (difference of the ones)

$\begin{array}{r} 34 \\ - 22 \\ \hline \end{array}$	$\begin{array}{r} 46 \\ - 22 \\ \hline \end{array}$	$\begin{array}{r} 65 \\ - 55 \\ \hline \end{array}$
$\begin{array}{r} 24 \\ - 12 \\ \hline \end{array}$	$\begin{array}{r} 47 \\ - 23 \\ \hline \end{array}$	$\begin{array}{r} 57 \\ - 55 \\ \hline \end{array}$
$\begin{array}{r} 79 \\ - 45 \\ \hline \end{array}$	$\begin{array}{r} 58 \\ - 26 \\ \hline \end{array}$	$\begin{array}{r} 75 \\ - 44 \\ \hline \end{array}$

Teacher's Remark(s):

Teacher's Signature and Date:

Find the **differences** for the following subtractions using the place value tables.

Example:  $57 - 23$

Tens	Ones
5	7
- 2	3
3	4

$$57 - 23 = 34$$

Tens	Ones
3	4
- 2	2

$$34 - 22 = \underline{\quad}$$

Tens	Ones
4	6
- 2	3

$$46 - 23 = \underline{\quad}$$

Tens	Ones
2	4
- 1	2

$$24 - 12 = \underline{\quad}$$

Tens	Ones
8	7
- 5	3

$$87 - 53 = \underline{\quad}$$

Tens	Ones
5	8
- 2	6

$$58 - 26 = \underline{\quad}$$

Tens	Ones
5	7
- 5	5

$$57 - 55 = \underline{\quad}$$

Tens	Ones
8	7
- 3	5

$$87 - 35 = \underline{\quad}$$

Tens	Ones
3	6
- 2	4

$$36 - 24 = \underline{\quad}$$

Tens	Ones
7	9
- 6	8

$$79 - 68 = \underline{\quad}$$

Teacher's Remark(s):

Teacher's Signature and Date:

Find the **differences** for the following subtractions, which require regrouping, using the place value tables.

Example: 62 - 38

Tens	Ones
<del>6</del> 5	<del>2</del> 12
- 3	8
2	4

Since we cannot subtract 8 ones from 2 ones because 8 is greater than 2, we regroup 62, which is 6 tens and 2 ones, as **5 tens and 12 ones**.

Now, we can subtract **8 ones** from **12 ones** to get **4 ones**, and we can also subtract **3 tens** from **5 tens** to get **2 tens**.

62 - 38 = 24

Tens	Ones
7	1
- 2	9

71 - 29 = \_\_\_\_\_

Tens	Ones
4	3
- 1	8

43 - 18 = \_\_\_\_\_

Tens	Ones
5	2
- 3	8

52 - 38 = \_\_\_\_\_

Tens	Ones
6	0
- 2	5

60 - 25 = \_\_\_\_\_

Teacher's Remark(s):

Teacher's Signature and Date:

Solve the following problems by either adding or subtracting the numbers in the stories. Show how you added or subtracted.

1. Karma went to buy some sugar and some salt from a shop. He paid Nu 55 for a packet of sugar and Nu 12 for a packet of salt. How much money did Karma spend altogether?
  
  
  
  
  
  
  
  
  
  
2. How much more did the sugar cost than the salt in the above story?
  
  
  
  
  
  
  
  
  
  
3. Lhamo has Nu 95. She gave Nu 25 to her younger sister. Now, how much money is left with Lhamo?

---

Teacher's Remark(s):

Teacher's Signature and Date:

---

Fill in the extended 100-chart with numbers beyond 100.

1	2	3	4	5	6	7	8	9	10
11	12	13	14	15	16	17	18	19	20
21	22	23	24	25	26	27	28	29	30
31	32	33	34	35	36	37	38	39	40
41	42	43	44	45	46	47	48	49	50
51	52	53	54	55	56	57	58	59	60
61	62	63	64	65	66	67	68	69	70
71	72	73	74	75	76	77	78	79	80
81	82	83	84	85	86	87	88	89	90
91	92	93	94	95	96	97	98	99	100
101									
									200

---

Teacher's Remark(s):

---

Teacher's Signature and Date:

Write the number words for the numerals.

<b>Numeral</b>	<b>Number word</b>
0	
1	
2	
3	
4	
5	
6	
7	
8	
9	
10	

<b>Numeral</b>	<b>Number word</b>
11	
12	
13	
14	
15	
16	
17	
18	
19	
20	
21	

<b>Numeral</b>	<b>Number word</b>
22	
23	
24	
25	
26	
27	
28	

<b>Numeral</b>	<b>Number word</b>
29	
30	
31	
32	
33	
34	
35	

Teacher's Remark(s):

Teacher's Signature and Date:

Write the number words for the numerals.

<b>Numeral</b>	<b>Number word</b>
40	
50	
60	
70	
80	
90	
100	
101	
102	
103	
104	

<b>Numeral</b>	<b>Number word</b>
110	
111	
112	
113	
114	
115	
196	
197	
198	
199	
200	

<b>Numeral</b>	<b>Number word</b>
201	
202	
203	
204	
205	
206	
207	

<b>Numeral</b>	<b>Number word</b>
300	
400	
500	
600	
700	
800	
900	

Teacher's Remark(s):

Teacher's Signature and Date:

The following diagrams represent the models for the numbers 1, 10 and 100.

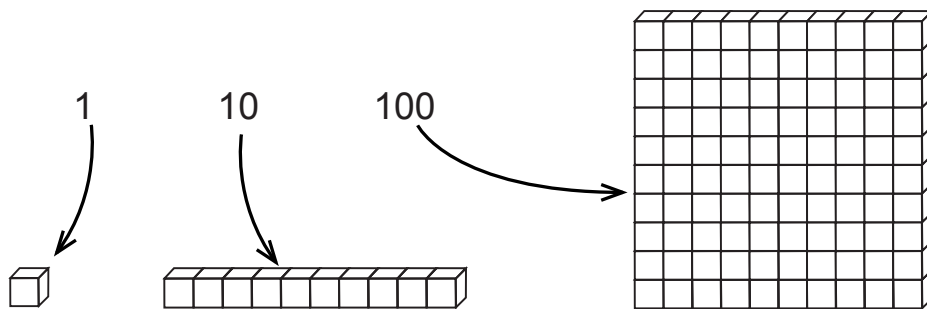

What number does each set of the following diagrams represent?

<p>_____</p>	<p>_____</p>
<p>_____</p>	<p>_____</p>

Teacher's Remark(s):

Teacher's Signature and Date:



What number does each set of the following diagrams represent?

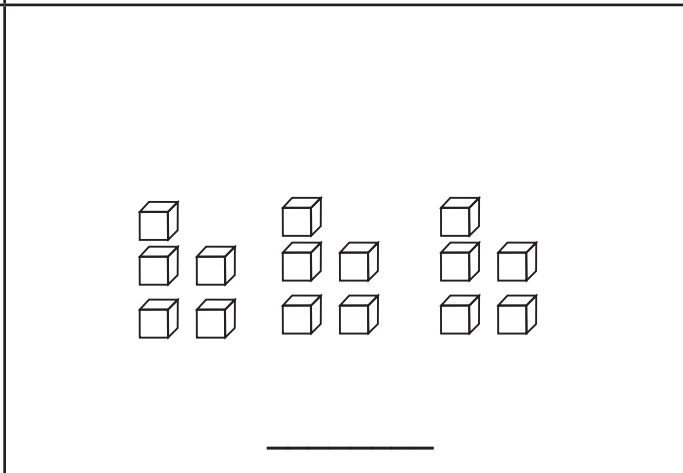
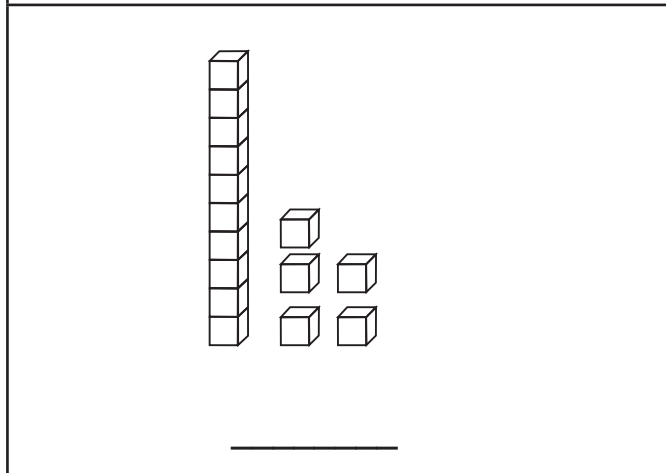
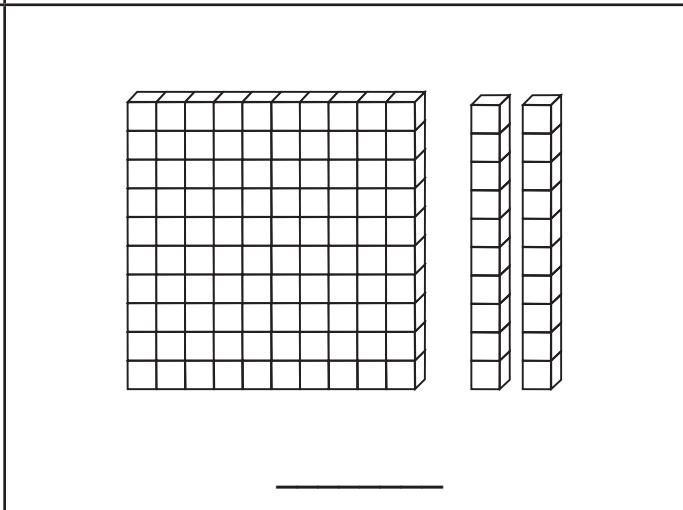
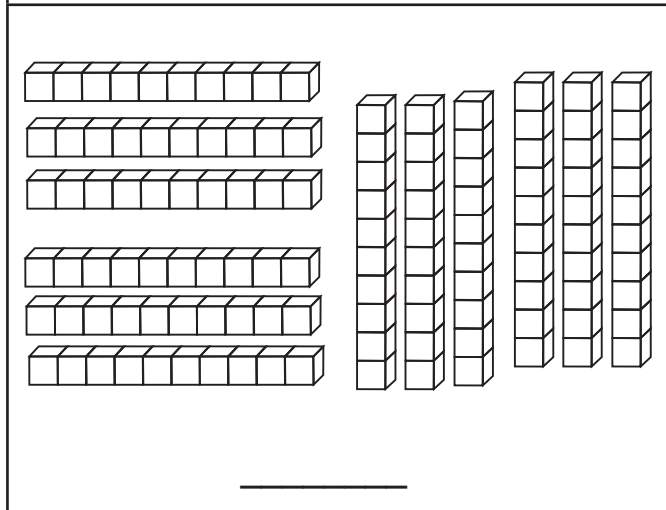
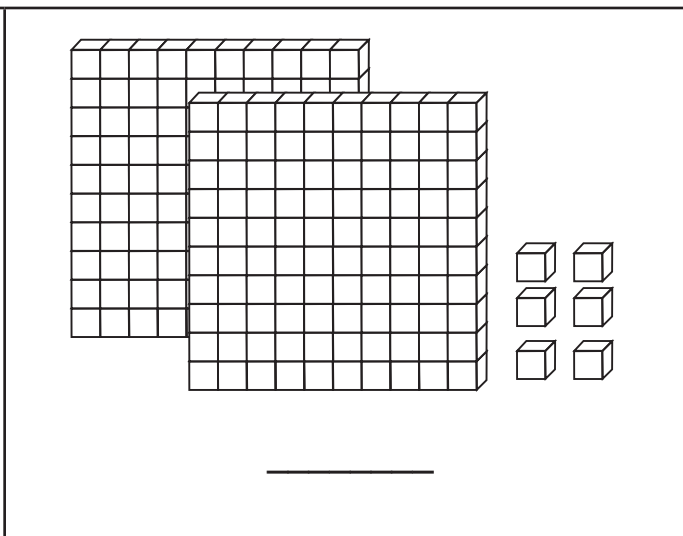
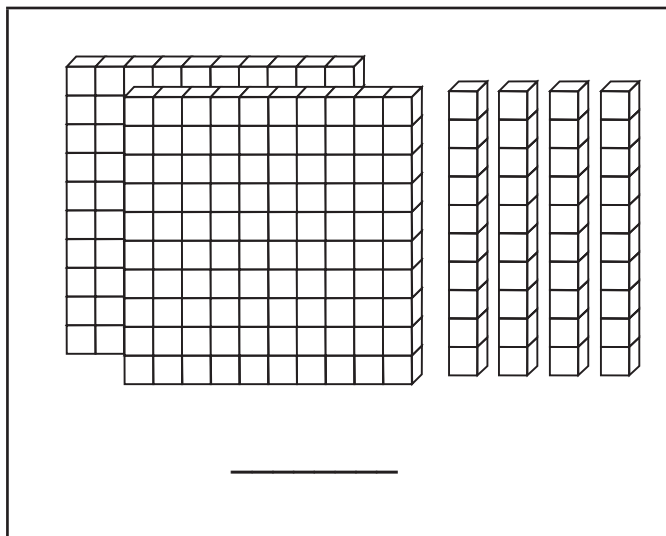

Teacher's Remark(s):

Teacher's Signature and Date:

Describe the numbers as groups of hundreds, tens and ones.

Example:  $526 = 5$  hundreds  $2$  tens  $6$  ones

$236 =$  \_\_\_\_\_ hundreds \_\_\_\_\_ tens \_\_\_\_\_ ones

$258 =$  \_\_\_\_\_ hundreds \_\_\_\_\_ tens \_\_\_\_\_ ones

$797 =$  \_\_\_\_\_ hundreds \_\_\_\_\_ tens \_\_\_\_\_ ones

$450 =$  \_\_\_\_\_ hundreds \_\_\_\_\_ tens \_\_\_\_\_ ones

$902 =$  \_\_\_\_\_ hundreds \_\_\_\_\_ tens \_\_\_\_\_ ones

$64 =$  \_\_\_\_\_ hundreds \_\_\_\_\_ tens \_\_\_\_\_ ones

$347 =$  \_\_\_\_\_

$123 =$  \_\_\_\_\_

$605 =$  \_\_\_\_\_

$870 =$  \_\_\_\_\_

Write the numbers described below.

Example:  $8$  hundreds  $4$  tens  $6$  ones  $= 846$

$5$  hundreds  $3$  tens  $9$  ones  $=$  \_\_\_\_\_

$4$  hundreds  $6$  tens  $3$  ones  $=$  \_\_\_\_\_

$7$  hundreds  $0$  tens  $5$  ones  $=$  \_\_\_\_\_

$0$  hundreds  $7$  tens  $3$  ones  $=$  \_\_\_\_\_

$8$  hundreds  $5$  tens  $0$  ones  $=$  \_\_\_\_\_

---

Teacher's Remark(s):

---

Teacher's Signature and Date:

Describe the following numbers as groups of tens.

Example:  $20 = 2$  tens

$70 =$  \_\_\_\_ tens

$120 =$  \_\_\_\_ tens

$30 =$  \_\_\_\_ tens

$80 =$  \_\_\_\_ tens

$130 =$  \_\_\_\_ tens

$40 =$  \_\_\_\_ tens

$90 =$  \_\_\_\_ tens

$140 =$  \_\_\_\_ tens

$50 =$  \_\_\_\_ tens

$100 =$  \_\_\_\_ tens

$150 =$  \_\_\_\_ tens

$60 =$  \_\_\_\_ tens

$110 =$  \_\_\_\_ tens

$10 =$  \_\_\_\_ tens

Describe the following numbers as groups of hundreds, tens and ones.

Example:  $146 = 1$  hundred  $4$  tens  $6$  ones

$235 =$  \_\_\_\_ hundreds \_\_\_\_ tens \_\_\_\_ ones

$154 =$  \_\_\_\_\_

$260 =$  \_\_\_\_\_

Describe the following numbers as groups of tens and ones.

Example:  $146 = 14$  tens  $6$  ones

$235 =$  \_\_\_\_ tens \_\_\_\_ ones

$154 =$  \_\_\_\_\_

$260 =$  \_\_\_\_\_

---

Teacher's Remark(s):

Teacher's Signature and Date:

Extend the following number patterns.

100, 200, 300, 400, \_\_\_\_\_, \_\_\_\_\_, \_\_\_\_\_, \_\_\_\_\_, \_\_\_\_\_

25, 50, 75, 100, 125, \_\_\_\_\_, \_\_\_\_\_, \_\_\_\_\_, \_\_\_\_\_, \_\_\_\_\_

175, 200, 225, 250, \_\_\_\_\_, \_\_\_\_\_, \_\_\_\_\_, \_\_\_\_\_, \_\_\_\_\_

400, 500, 600, \_\_\_\_\_, \_\_\_\_\_, \_\_\_\_\_, \_\_\_\_\_

10, 20, 30, 40, \_\_\_\_\_, \_\_\_\_\_, \_\_\_\_\_, \_\_\_\_\_, \_\_\_\_\_, \_\_\_\_\_

80, 90, 100, 110, 120, \_\_\_\_\_, \_\_\_\_\_, \_\_\_\_\_, \_\_\_\_\_, \_\_\_\_\_

200, 210, 220, 230, \_\_\_\_\_, \_\_\_\_\_, \_\_\_\_\_, \_\_\_\_\_, \_\_\_\_\_

900, 800, 700, \_\_\_\_\_, \_\_\_\_\_, \_\_\_\_\_, \_\_\_\_\_, \_\_\_\_\_, \_\_\_\_\_

90, 80, 70, \_\_\_\_\_, \_\_\_\_\_, \_\_\_\_\_, \_\_\_\_\_, \_\_\_\_\_, \_\_\_\_\_

200, 175, 150, \_\_\_\_\_, \_\_\_\_\_, \_\_\_\_\_, \_\_\_\_\_, \_\_\_\_\_

Create a number pattern which starts with 200 and the numbers increase by 100 each time.

Create a number pattern which starts with 125 and the numbers increase by 25 each time.

---

Teacher's Remark(s):

Teacher's Signature and Date:

Show or indicate where the following numbers would be on the number line.

150, 310, 499, 205, 350, 450, 700

Example: 150

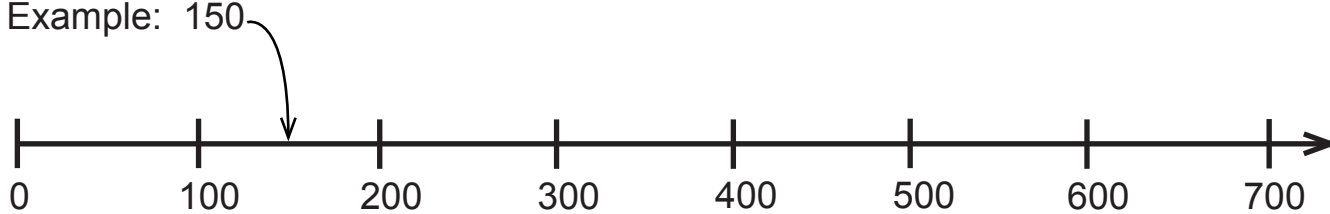

Show or indicate where the following numbers would be on the number line given below.

115, 129, 135, 153, 171



Make a number line and show the following numbers on it.

0, 50, 100, 150, 200, 250, 300

---

Teacher's Remark(s):

Teacher's Signature and Date:

Compare the pairs of numbers and write “is greater than”, “is less than”, or “is equal to” between them.

$250 \underline{\hspace{2cm}} 199$

$123 \underline{\hspace{2cm}} 97$

$99 \underline{\hspace{2cm}} 100$

$651 \underline{\hspace{2cm}} 651$

$500 \underline{\hspace{2cm}} 87$

$720 \underline{\hspace{2cm}} 270$

$50 \underline{\hspace{2cm}} 150$

$800 \underline{\hspace{2cm}} 800$

Compare the pairs of numbers and write the signs  $>$ ,  $<$ , or  $=$  in the boxes between them.

$40 \boxed{\phantom{0}} 30$

$123 \boxed{\phantom{0}} 96$

$30 \boxed{\phantom{0}} 40$

$651 \boxed{\phantom{0}} 651$

$30 \boxed{\phantom{0}} 30$

$96 \boxed{\phantom{0}} 100$

$214 \boxed{\phantom{0}} 314$

$900 \boxed{\phantom{0}} 900$

$314 \boxed{\phantom{0}} 99$

$555 \boxed{\phantom{0}} 600$

$770 \boxed{\phantom{0}} 690$

$670 \boxed{\phantom{0}} 669$

Teacher's Remark(s):

Teacher's Signature and Date:

The bar graph below shows the pet animals the students in a class have. Answer the questions based on the graph.

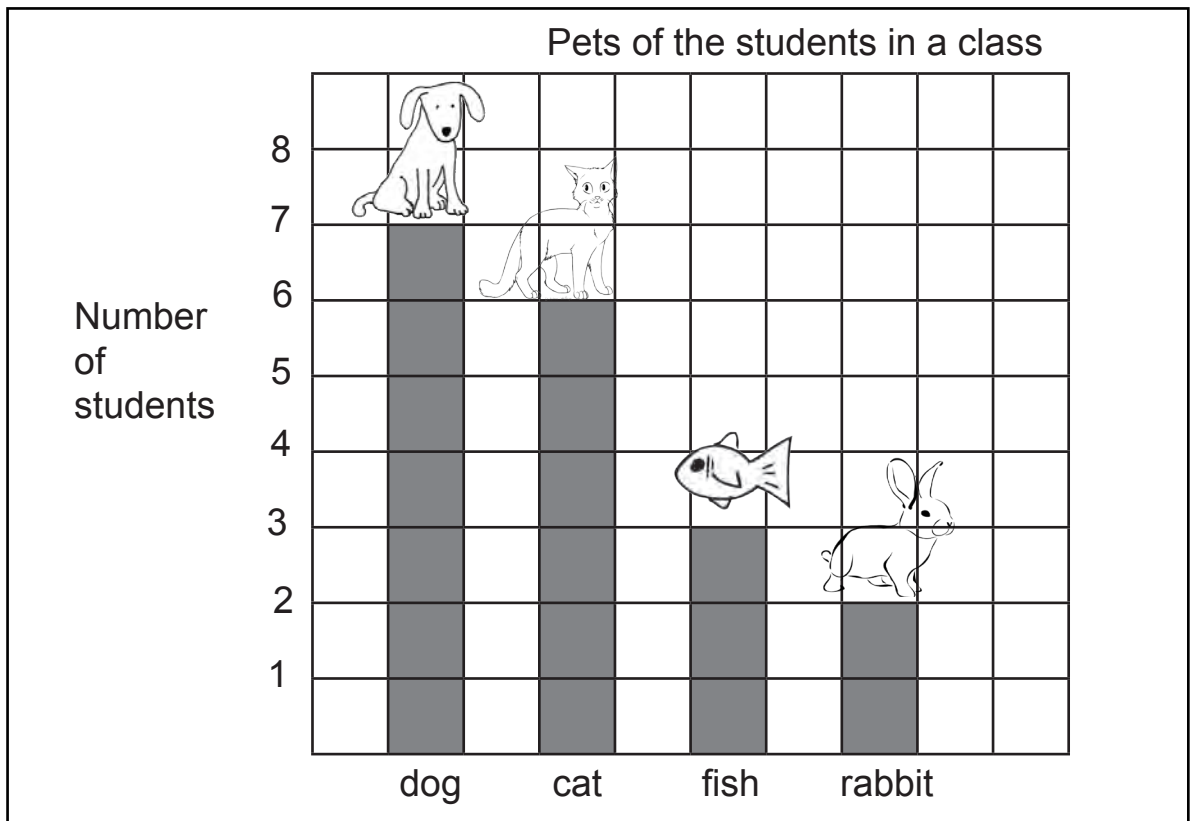

1. Name the pet animals that the students in the class have?

---

2. Which pet is owned by the most number of students in the class?

---

3. How many students have fish as their pet?

---

4. What is the title of the bar graph?

---

Teacher's Remark(s):

Teacher's Signature and Date:

The bar graph below shows the favourite fruits of the students in a class. Answer the questions based on it.

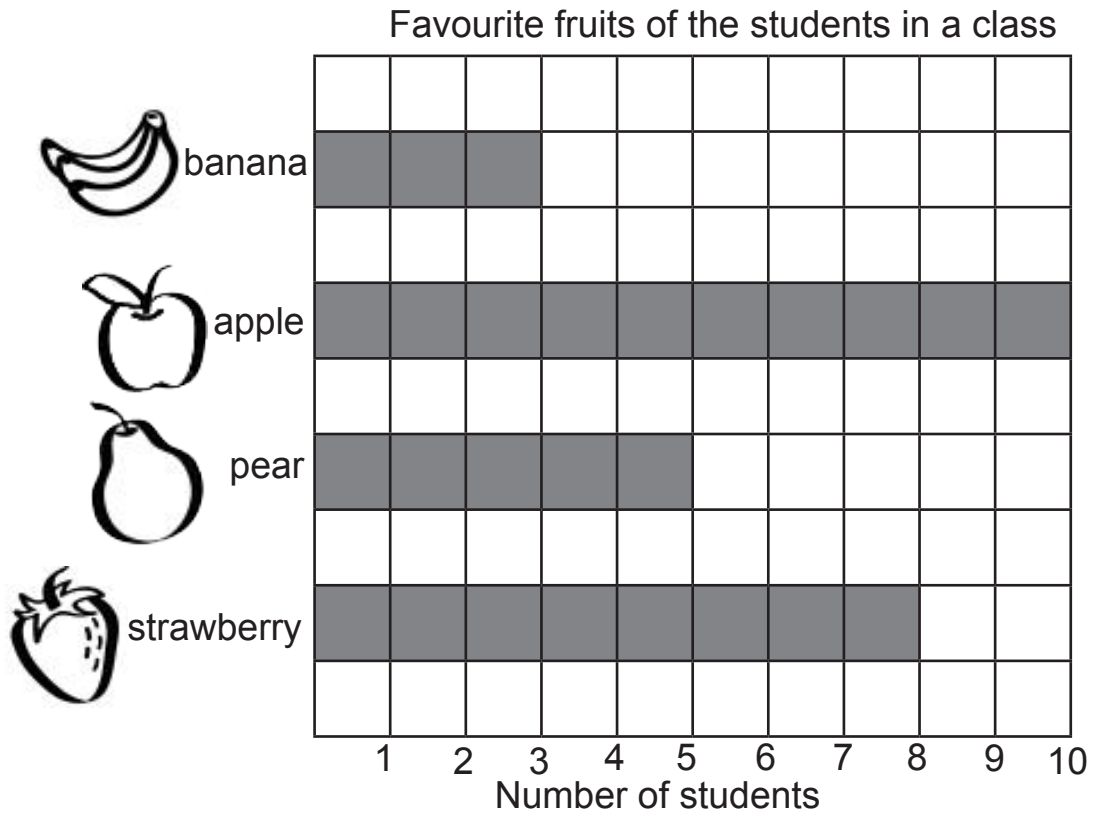

1. Are the bars in the graph vertical or horizontal?  
\_\_\_\_\_
2. How many students had said that apple is their favourite fruit?  
\_\_\_\_\_
3. What does the shortest bar tell?  
\_\_\_\_\_
4. How many students are there in this class as per this graph?  
\_\_\_\_\_
5. What is your favourite fruit?  
\_\_\_\_\_

Teacher's Remark(s): \_\_\_\_\_

Teacher's Signature and Date: \_\_\_\_\_



Make a bar graph for the number of sisters the students in your class have on the grid below. Do not forget to write the **title** and the **labels** for your graph.

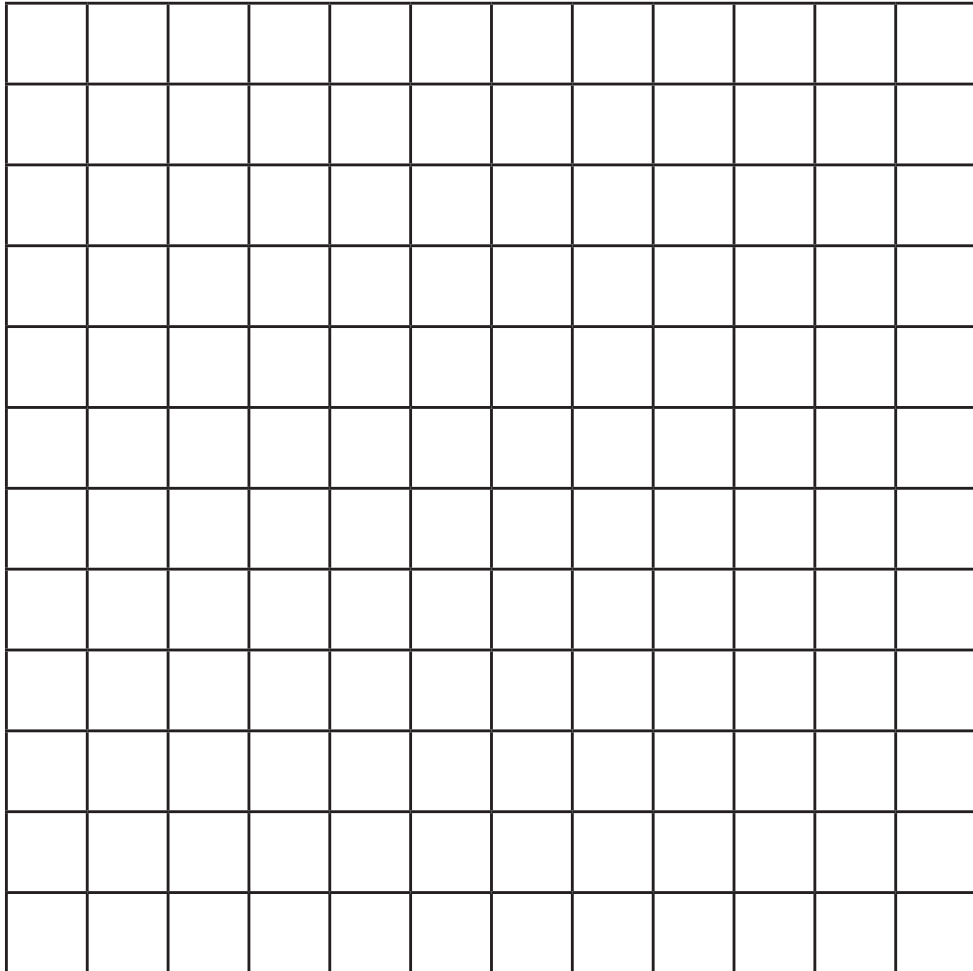

---

Teacher's Remark(s):

---

Teacher's Signature and Date:

Make a bar graph for the data you have collected about your friends during an earlier lesson on the grid provided below. Do not forget to write the **title** and the **labels** for your graph. You can make your bars either horizontal or vertical.

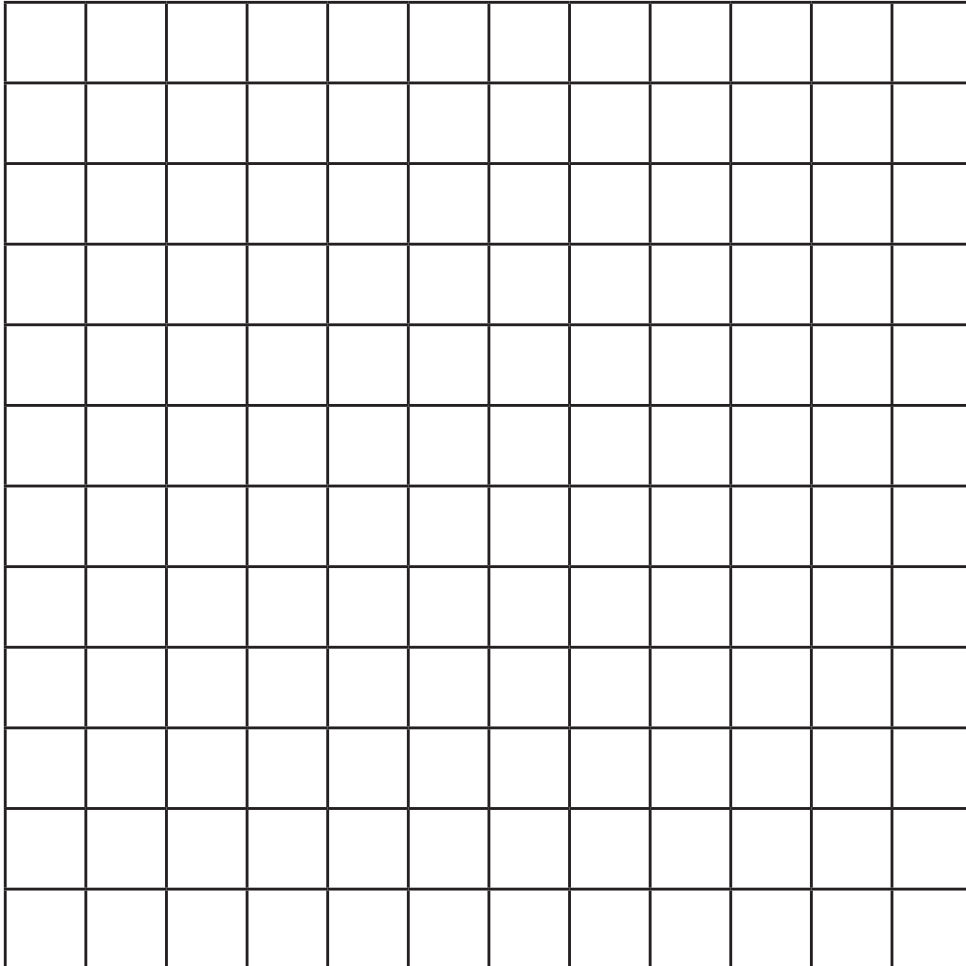

---

Teacher's Remark(s):

Teacher's Signature and Date:

What is the probability of each of the following situations happening. Read the statements and write one of these words (**certain**, **impossible**, **likely**, **unlikely**) after the each statement.

1. A yak will be a student in your class next year. \_\_\_\_\_
2. Tomorrow will be a sunny day. \_\_\_\_\_
3. Crows will become white when they grow old. \_\_\_\_\_
4. Some of your friends will become teachers in the future. \_\_\_\_\_
5. All of your friends will become teachers in the future. \_\_\_\_\_
6. Someday humans will grow wings and fly like birds. \_\_\_\_\_
7. If you put a stone in water, it will not sink. \_\_\_\_\_
8. It will snow this winter in your school. \_\_\_\_\_
9. One day you will fly in the Druk Air. \_\_\_\_\_
10. His Majesty the King will visit your school this year. \_\_\_\_\_

Write a statement for which you think the probability will be **certain**.

Write a statement for which you think the probability will be **impossible**.

---

Teacher's Remark(s):

---

Teacher's Signature and Date:

Palden rolled a pair of dice again and again, and recorded the **sums** of the numbers rolled each time as shown below. Answer the questions that follow.



Sum	
1	
2	
3	
4	
5	
6	

Sum	
7	
8	
9	
10	
11	
12	

- How many times had Palden rolled the dice?  
\_\_\_\_\_
- What sum did Palden get the most number of times?  
\_\_\_\_\_
- If he rolls the dice one more time, what would most likely be the sum?  
\_\_\_\_\_
- As you can see, Palden has not got 9 as a sum. Do you think he can get 9 as a sum if he rolls the dice some more times?  
\_\_\_\_\_
- Can Palden ever get 13 as a sum for his pair of dice? Why  
\_\_\_\_\_

Teacher's Remark(s): \_\_\_\_\_

Teacher's Signature and Date: \_\_\_\_\_

Look at the diagrams below and answer the questions that follow.

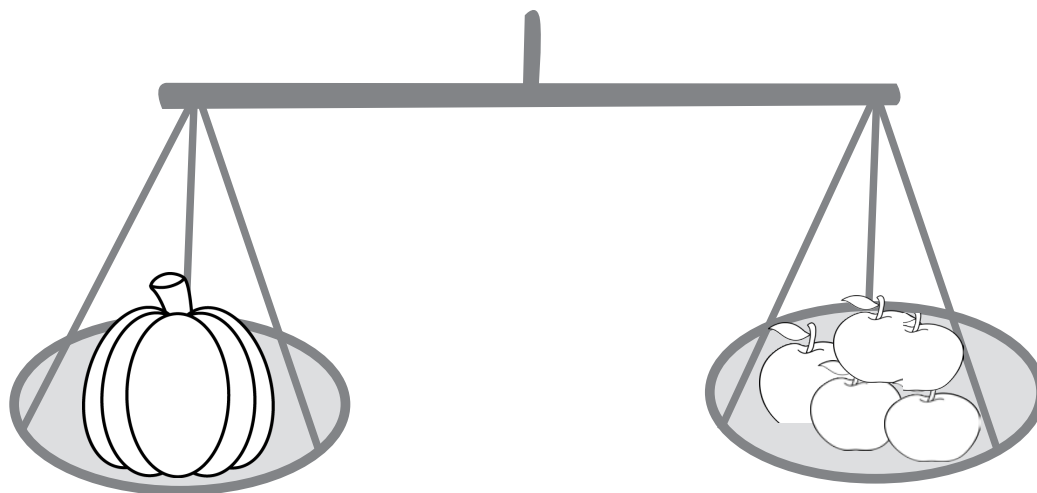

1. What is the **mass** of the pumpkin?

The **mass** of the pumpkin is \_\_\_\_\_ apples.

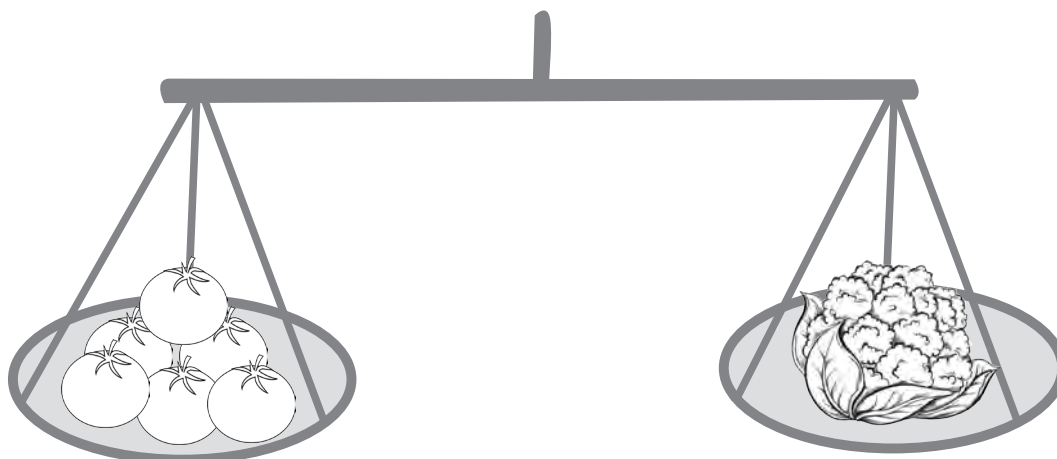

2. What is the **mass** of the cauliflower?

\_\_\_\_\_

Teacher's Remark(s):

Teacher's Signature and Date:

Look at the diagrams below and answer the questions that follow.

**Question:** What is the mass of the potatoes?

**Answer:** \_\_\_\_\_  
 \_\_\_\_\_



1 Kilogram



**Question:** How many kilograms of rice are there in this sack?

**Answer:** \_\_\_\_\_

Draw a picture of an object that has a **mass** of less than 1 kilogram.

---

Teacher's Remark(s):

---

Teacher's Signature and Date:

Look at the diagrams below and answer the questions that follows.

A bottle of apple juice can fill three glasses.



Apple Juice



Glasses

1. What is the **capacity** of the bottle?

The capacity of the bottle is \_\_\_\_\_ glasses.

A rectangular box can accommodate exactly 60 identical cubes.

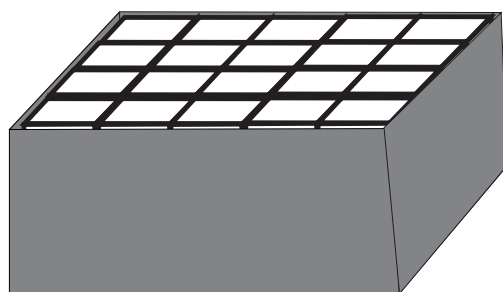

Box



Cube

2. What is the **capacity** of the box?

\_\_\_\_\_

Teacher's Remark(s):

Teacher's Signature and Date:

This jug can hold exactly 1 litre of water. So, the capacity of the jug is 1 litre.

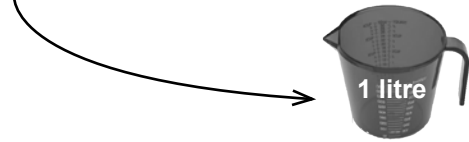

This bucket can hold exactly 10 jugful of water.



**Question:** What is the **capacity** of the bucket?

**Answer:** The capacity of the bucket is \_\_\_\_\_ litres.

Look at the following pictures of the containers and choose the appropriate capacity for each, by ticking the phrase “More than 1 litre” or “Less than 1 litre”.

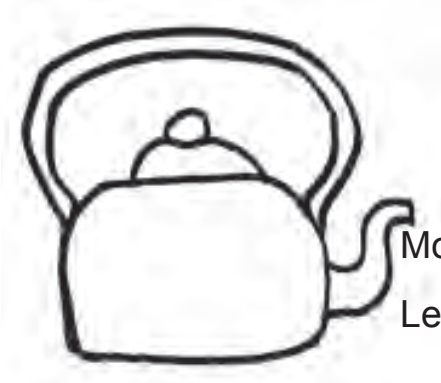

More than 1 litre  
Less than 1 litre



More than 1 litre  
Less than 1 litre



More than 1 litre  
Less than 1 litre



More than 1 litre  
Less than 1 litre

Teacher’s Remark(s):

Teacher’s Signature and Date:



Answer the following questions.

1. How many days are there in a week?

---

2. Write the names of the days in a week.

---

---

3. What day comes before Wednesday?

---

4. How many months are there in a year?

---

5. What is the 1<sup>st</sup> month of the year?

---

6. What is the 11<sup>th</sup> month of the year?

---

7. Write the names of the 4 seasons.

---

8. During which season do you have a long holiday from the school?

---

---

Teacher's Remark(s):

Teacher's Signature and Date:

Write the time shown by each clock.



\_\_\_\_\_ minutes past \_\_\_\_\_ o'clock

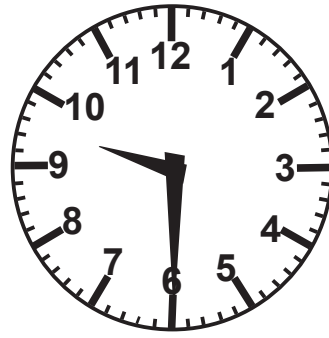

\_\_\_\_\_ minutes past \_\_\_\_\_ o'clock



\_\_\_\_\_ minutes past \_\_\_\_\_ o'clock

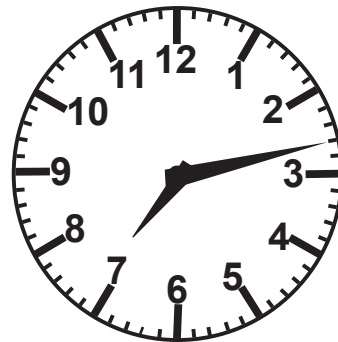

\_\_\_\_\_

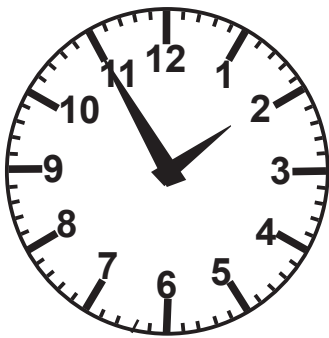

\_\_\_\_\_

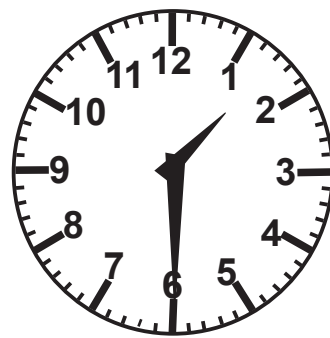

\_\_\_\_\_

Teacher's Remark(s):

Teacher's Signature and Date:

Draw the **minute hand** and the **hour hand** on each clock to show the time described below the clocks.

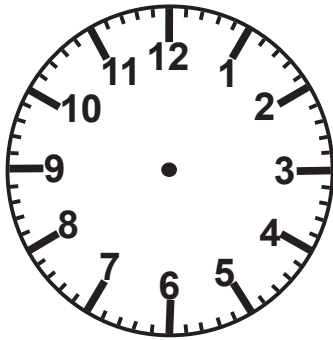

15 minutes past 8 o'clock

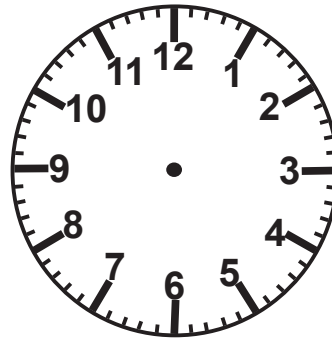

30 minutes past 3 o'clock

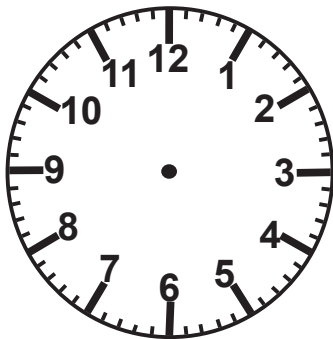

45 minutes past 10 o'clock

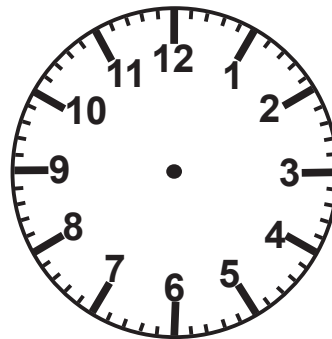

15 minutes past 10 o'clock

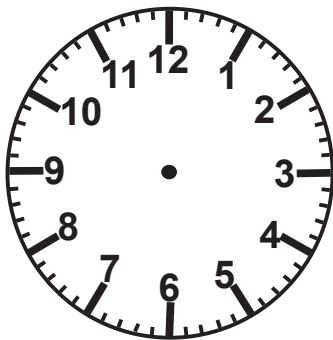

Half past 2 o'clock

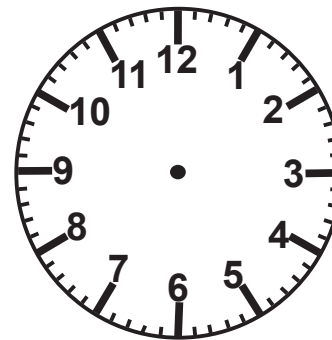

7 o'clock

---

Teacher's Remark(s):

---

Teacher's Signature and Date:

Write the times described below in digital clock format.

Example: 30 minutes past 9 o'clock	9:30
15 minutes past 6 o'clock	
0 minutes past 11 o'clock	
50 minutes past 4 o'clock	
5 minutes past 4 o'clock	

Describe the times written in the digital clock format.

Example: 6:05	5 minutes past 6 o'clock
6:45	
5:15	
10:20	
10:00	

---

Teacher's Remark(s):

Teacher's Signature and Date:



THIS PAGE IS LEFT BLANK

## Summative Assessment Recording Sheet

Student Name: \_\_\_\_\_ Roll no.: \_\_\_\_\_ Section: \_\_\_\_\_

### CHAPTER 1 NUMBERS TO 100

*Interview-based Performance Task (Please refer to the Introduction to the Teacher's Guide for Class 2 for the marking scheme while using the Interview-based Performance Task.)*

Task and Interview prompts	Key concepts and skills to look for
<p>Have 10-frames, counters and a calendar for the month ready. Present the student with a number, say 25, and tell/ask:</p> <p><b>Show me this number on the calendar. What date does it show? What day is the 25th of this month? Skip count by 5s backward from 25 to 0. How can you show 25 on 10-frames? Which number is more: 25 or 18? How can you show that? Or, How do you know that 25 is more than 18? Which of these two numbers, 18 and 25, is an even number? Can you show it is an even number?</b></p> <p>Present shrinking pattern (like; 12, 10, 8, ...), and ask:  <b>Can you extend this pattern? What kind of a pattern is this? Can you create/make a simple growing pattern? Explain how the pattern works.</b></p>	<p>The student is able to:</p> <ul style="list-style-type: none"> <li>- Say the dates in ordinal number form.</li> <li>- Read and relate dates with days on a calendar.</li> <li>- Skip count by 5s.</li> <li>- Represent numbers on 10-frames.</li> <li>- Compare numbers and say which is more/less.</li> <li>- Identify even numbers.</li> <li>- Show/represent even numbers.</li> <li>- Identify simple growing and shrinking patterns.</li> <li>- Extend simple patterns.</li> <li>- Create simple patterns.</li> </ul>
<p><b>Comments and Marks</b></p> <p>Strengths:</p>   <p>Areas of Need:</p>   <p>Follow up Steps:</p>   <p style="text-align: center;">Teacher's Signature and Date:</p>	

### Summary of the Summative Assessment for Chapter 1

CA marks from Chapter 1 (Marks out of 10): \_\_\_\_\_





## Summative Assessment Recording Sheet

Student Name: \_\_\_\_\_ Roll no.: \_\_\_\_\_ Section: \_\_\_\_\_

### CHAPTER 2 ADDITION AND SUBTRACTION STRATEGIES

*Interview-based Performance Task (Please refer to the Introduction to the Teacher's Guide for Class 2 for the marking scheme while using the Interview-based Performance Task.)*

Task and Interview prompts	Key concepts and skills to look for
<p>Provide the student with a set of snap cubes in two colours (e.g., 5 red cubes and 6 blue cubes), and a blank paper. And, ask: <b>Can you write an addition sentence for this set of cubes?</b> Use appropriate probing questions, if required. Have the student describe what each of the numbers in the sentence means. Have the student write the related addition and subtraction sentences, by asking questions such as: <b>Can you write this addition sentence in another way? How are these two addition sentences different? Why is the sum the same? Can you write a related subtraction sentence for this addition sentence? How do you know that <math>11 - 5 = 6</math>? What is another subtraction sentence for this situation?</b></p> <p>Have the student write an addition sentence using two different numbers, other than 5 and 6, for which the sum is 11. Ask him/her to tell how he/she determined the sum.</p> <p>Have the student write a subtraction sentence using two different numbers, other than 11 and 5, for which the difference is 6. Ask him/her to tell how he/she determined the sum.</p>	<p>The student is able to:</p> <ul style="list-style-type: none"> <li>- Represent a part-part-whole situation with an addition sentence.</li> <li>- Describe what each number in an addition sentence means.</li> <li>- Use the commutative property of addition.</li> <li>- Write the related addition and subtraction sentences for an addition sentence.</li> <li>- Write more than one addition fact for the same sum.</li> <li>- Use an appropriate strategy to add two numbers.</li> <li>- Write more than one subtraction fact for the same difference.</li> <li>- Use an appropriate strategy to find the difference of two numbers.</li> </ul>

#### Comments and Marks

Strengths:

Areas of Need:

Follow up Steps:

Teacher's Signature and Date:

#### Summary of the Summative Assessment for Chapter 2

CA marks from Chapter 2 (Marks out of 10): \_\_\_\_\_



## Summative Assessment Recording Sheet

Student Name: \_\_\_\_\_ Roll no.: \_\_\_\_\_ Section: \_\_\_\_\_

### CHAPTER 3 MEASURING LENGTH AND AREA

*Interview-based Performance Task (Please refer the Introduction to the Teacher's Guide for Class 2 for the marking scheme while using the Interview-based Performance Task.)*

Task and Interview prompts	Key concepts and skills to look for
<p>Have a 2-D shape drawn on a piece of paper, as shown below, some trapezoidal, rhomboidal and triangular pattern blocks ready. The shape should be such that it can fit 2 trapezoids, or 3 rhombuses, or 6 triangles on it.</p> <p>Ask the student: <b>Can you measure the area of this shape with one of these pattern blocks? So what is the area of this shape? Can you now measure the area with another of these blocks? What is the area using this unit? Has the area of the shape changed when you measured it with different units? Why has the number changed?</b></p> <p>Present the student with a rectangle that is 2 cm by 3 cm, and a ruler. Ask: <b>How many centimetres long do you think is this side of the rectangle</b> (indicating to one of the sides of the rectangle)? <b>Measure the side in centimetres using the ruler. So, how long is the side? Can you measure and write the perimeter of this shape in centimetres?</b></p> <p>Ask the student to draw a line that is 5 centimetres with the help of the ruler.</p>	<p>The student is able to:</p> <ul style="list-style-type: none"> <li>- Measure the area of a shape with non-standard units.</li> <li>- Describe the area of a shape in non-standard units.</li> <li>- Understand and tell that the area of a shape does not change even if we use different units to measure it.</li> <li>- Measure an area in more than one non-standard unit.</li> <li>- Make reasonable estimate of the length of a line in centimetres.</li> <li>- Measure the length of a line using a ruler correctly and express the length in centimetres.</li> <li>- Measure and record the perimeter of a shape in centimetres.</li> <li>- Draw a straight line for a given length in centimetres.</li> </ul>

#### Comments and Marks

Strengths:

Areas of Need:

Follow up Steps:

Teacher's Signature and Date:

#### Summary of the Summative Assessment for Chapter 3

CA marks from Chapter 3 (Marks out of 10): \_\_\_\_\_



## Summative Assessment Recording Sheet

Student Name: \_\_\_\_\_ Roll no.: \_\_\_\_\_ Section: \_\_\_\_\_

### CHAPTER 4 PLACE VALUE

*Interview-based Performance Task (Please refer to the Introduction to the Teacher's Guide for Class 2 for the marking scheme while using the Interview-based Performance Task.)*

Task and Interview prompts	Key concepts and skills to look for
<p>Have a place value chart with the columns for tens and ones, base ten blocks (tens and ones) ready.</p> <p>Provide the student with a 2-digit number, say 64, by writing it down on a paper, and ask:</p> <p><b>What is this number?</b></p> <p><b>Can you say this number in terms of tens and ones?</b></p> <p><b>Can you show this number with these blocks?</b></p> <p><b>Why is the tens on the left of the ones?</b></p> <p><b>Now, please put these block in this place value chart.</b></p> <p><b>If we add 20, or 2 tens to 64, what will be the sum?</b></p> <p><b>Write here <math>64 + 20 = 84</math>.</b></p> <p><b>What number in 64 has changed when you added 20? Why did that happen?</b></p> <p><b>Why did 4 not change when adding 20 to 64?</b></p>	<p>The student is able to:</p> <ul style="list-style-type: none"> <li>- Describe a number in terms of tens and ones.</li> <li>- Represent a number with base ten materials correctly.</li> <li>- Tell why the tens blocks are shown on the left of the ones blocks.</li> <li>- Place models for a number correctly on the place value chart.</li> <li>- Find the sum for adding 10s to a number correctly.</li> <li>- Explain why only the tens digit change when 10s are added to a number.</li> </ul>

#### Comments and Marks

Strengths:

Areas of Need:

Follow up Steps:

Teacher's Signature and Date:

#### Summary of the Summative Assessment for Chapter 4

CA marks from Chapter 4 (Marks out of 10): \_\_\_\_\_









## Summative Assessment Recording Sheet

Student Name: \_\_\_\_\_ Roll no.: \_\_\_\_\_ Section: \_\_\_\_\_

### CHAPTER 6 GEOMETRY

*Interview-based Performance Task (Please refer to the Introduction to the Teacher's Guide for Class 2 for the marking scheme while using the Interview-based Performance Task.)*

Task and Interview prompts	Key concepts and skills to look for
<p>Provide the student with models of a prism and a pyramid. Ask questions such as: <b>Which one of these is a prism? Which one is a pyramid? What is different about a prism and a pyramid? Show me the apex of this pyramid. How many edges can you count on this pyramid? What is the shape of the base of this pyramid? So, what is the name of this pyramid? What is the name of this prism?</b></p> <p>Provide the students a cylinder, and ask: <b>What is the same about this cylinder and this prism? What is different about the cylinder and the prism?</b></p> <p>Provide the student with cutouts of a rectangle which is not a square and a square. Tell: <b>These are both rectangles. Can you tell me what is different about these two rectangles? What do you call a rectangle that has all its 4 sides the same in length? This long rectangle has 2 lines of symmetry. Can you show me the lines of symmetry in it by folding the shape? Now how many lines of symmetry are there in this square? How many pairs of parallel lines are there in a rectangle? Can you show them?</b></p>	<p>The student is able to:</p> <ul style="list-style-type: none"> <li>- Identify prisms and pyramids.</li> <li>- Name prisms and pyramids according to the shape of their bases.</li> <li>- Tell the difference between a prism and a pyramid.</li> <li>- Describe the similarities between a prism and a pyramid.</li> <li>- Count the number of corners and edges in a 3-D shape.</li> <li>- Compare and describe the similarities and difference between a prism and a cylinder.</li> <li>- Recognise a square as a rectangle that has all the 4 sides equal in length.</li> <li>- Tell the difference between a square and a rectangle which is not a square.</li> <li>- Determine the lines of symmetry in a simple shape.</li> <li>- Recognise the pair of parallel lines in a rectangle.</li> </ul>

#### Comments and Marks

Strengths:

Areas of Need:

Follow up Steps:

Teacher's Signature and Date:

#### Summary of the Summative Assessment for Chapter 6

CA marks from Chapter 6 (Marks out of 10): \_\_\_\_\_



## Summative Assessment Recording Sheet

Student Name: \_\_\_\_\_ Roll no.: \_\_\_\_ Section: \_\_\_\_

### CHAPTER 7 TWO-DIGIT ADDITION AND SUBTRACTION

*Interview-based Performance Task (Please refer to the Introduction to the Teacher's Guide for Class 2 for the marking scheme while using the Interview-based Performance Task.)*

Task and Interview prompts	Key concepts and skills to look for																
<p>Ask the students: <b>What is the sum of 50 and 20? How did you add <math>50 + 20</math>? Can you write the addition sentence for <math>50 + 20</math> including their sum?</b></p> <p><b>How much more is 50 than 20? How do you know the difference? Write the subtraction sentence for <math>50 - 20</math> including their difference.</b></p> <p>Provide the student with a 2-digit addition on a place value table to solve, such as the one shown here. Ask related questions.</p> <table border="1" style="margin-left: auto; margin-right: auto; border-collapse: collapse; text-align: center;"> <thead> <tr> <th style="padding: 2px 10px;">Tens</th> <th style="padding: 2px 10px;">Ones</th> </tr> </thead> <tbody> <tr> <td style="padding: 2px 10px;">6</td> <td style="padding: 2px 10px;">5</td> </tr> <tr> <td style="padding: 2px 10px;">+ 2</td> <td style="padding: 2px 10px;">8</td> </tr> <tr> <td style="padding: 2px 10px;"> </td> <td style="padding: 2px 10px;"> </td> </tr> </tbody> </table> <p>Ask the student to solve a 2-digit subtraction on a place value table, such as the one provided here. Ask related questions.</p> <table border="1" style="margin-left: auto; margin-right: auto; border-collapse: collapse; text-align: center;"> <thead> <tr> <th style="padding: 2px 10px;">Tens</th> <th style="padding: 2px 10px;">Ones</th> </tr> </thead> <tbody> <tr> <td style="padding: 2px 10px;">6</td> <td style="padding: 2px 10px;">5</td> </tr> <tr> <td style="padding: 2px 10px;">- 2</td> <td style="padding: 2px 10px;">8</td> </tr> <tr> <td style="padding: 2px 10px;"> </td> <td style="padding: 2px 10px;"> </td> </tr> </tbody> </table>	Tens	Ones	6	5	+ 2	8			Tens	Ones	6	5	- 2	8			<p>The student is able to:</p> <ul style="list-style-type: none"> <li>- Add multiples of 10 mentally.</li> <li>- Describe the strategy used in adding 2-digit numbers.</li> <li>- Subtract multiples of 10 mentally.</li> <li>- Explain the strategy used in subtracting multiples of 10.</li> <li>- Add 2-digit numbers with regrouping on a place value table.</li> <li>- Subtract 2-digit numbers with regrouping on a place value table.</li> </ul>
Tens	Ones																
6	5																
+ 2	8																
Tens	Ones																
6	5																
- 2	8																
<b>Comments and Marks</b>																	
<p>Strengths:</p>   <p>Areas of Need:</p>   <p>Follow up Steps:</p>   <p style="text-align: right; margin-right: 50px;">Teacher's Signature and Date:</p>																	

#### Summary of the Summative Assessment for Chapter 7

CA marks from Chapter 7 (Marks out of 10): \_\_\_\_\_



## Summative Assessment Recording Sheet

Student Name: \_\_\_\_\_ Roll no.: \_\_\_\_\_ Section: \_\_\_\_\_

### CHAPTER 8 NUMBERS GREATER THAN 100

*Interview-based Performance Task (Please refer the Introduction to the Teacher's Guide for Class 2 for the marking scheme while using the Interview-based Performance Task.)*

Task and Interview prompts	Key concepts and skills to look for
<p>Have base ten blocks and a blank paper ready. Write a 3-digit number (e.g. 236) on the paper, and ask the student:  <b>Represent this number with the base ten blocks. How can you describe 236 as groups of hundred, tens and ones?</b>  <b>How can you represent 236 by using only the ten and ones blocks and not using any hundred blocks?</b>  <b>Now describe 236 in terms of only tens and ones. Write 236 in words.</b></p> <p>Write another number (e.g. 250) next to 236, as shown here: 236 250. Ask: <b>Which is greater: 236 or 250? Why? Which number is less then? Write the symbol: &gt; or &lt; between these two numbers.</b></p> <p>Write the following sequences on the paper, and ask the student to complete them. Ask how they know the remaining numbers in each of the sequences.</p> <p>300, 400, 500, _____, _____, _____</p> <p>125, 150, 175, 200, _____, _____, _____, _____</p>	<p>The student is able to:</p> <ul style="list-style-type: none"> <li>- Model a 3-digit number with base ten blocks in more than one way.</li> <li>- Describe a 3-digit number in terms of hundreds, tens and ones.</li> <li>- Describe a 3-digit number in terms of only tens and ones.</li> <li>- Write a 3-digit number in number words.</li> <li>- Compare 3-digit numbers and say which is greater and which number is less.</li> <li>- Use the greater than sign and less than sign correctly.</li> <li>- Skip count numbers in 100s.</li> <li>- Skip count numbers in 25s</li> </ul>
<b>Comments and Marks</b>	
<p>Strengths:</p>          <p>Areas of Need:</p>          <p>Follow up Steps:</p>          <p style="text-align: center;">Teacher's Signature and Date: _____</p>	

#### Summary of the Summative Assessment for Chapter 8

CA marks from Chapter 8 (Marks out of 10): \_\_\_\_\_



## Summative Assessment Recording Sheet

Student Name: \_\_\_\_\_ Roll no.: \_\_\_\_\_ Section: \_\_\_\_\_

### CHAPTER 9 DATA AND PROBABILITY

*Interview-based Performance Task (Please refer to the Introduction to the Teacher's Guide for Class 2 for the marking scheme while using the Interview-based Performance Task.)*

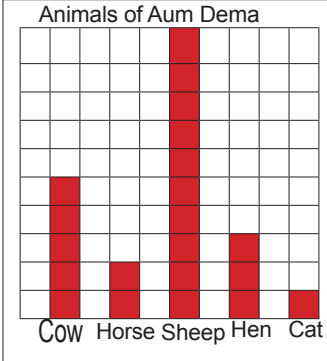
Task and Interview prompts	Key concepts and skills to look for												
<p>Make a bar graph as shown here on a paper. Explain what it shows briefly and ask the student questions such as:</p> <p><b>How many types of animals does Aum Dema have? How many cats does she have? Which animal does she have the greatest number of? What is the title of this bar graph?</b></p> <div style="text-align: center;">  <table border="1" style="margin: 0 auto; border-collapse: collapse; text-align: center;"> <caption>Animals of Aum Dema</caption> <thead> <tr> <th>Animal</th> <th>Count</th> </tr> </thead> <tbody> <tr> <td>COW</td> <td>3</td> </tr> <tr> <td>Horse</td> <td>2</td> </tr> <tr> <td>Sheep</td> <td>5</td> </tr> <tr> <td>Hen</td> <td>3</td> </tr> <tr> <td>Cat</td> <td>1</td> </tr> </tbody> </table> </div> <p>Put about 3 red cubes and 15 blue cubes in a feely bag or a container, with the full knowledge of the student. Mix the cubes thoroughly. Tell the student to say a probability word (certain, impossible, possible, likely, unlikely) for the statements you will make related to drawing out cubes from the container without looking. Ask the student to tell the reason for the choice of the words for each situation.</p> <p><b>I will draw out a blue cube.</b>  <b>I will draw out a red cube.</b>  <b>I will draw out a black cube.</b>  <b>I will draw out either a blue cube or a red cube.</b></p>	Animal	Count	COW	3	Horse	2	Sheep	5	Hen	3	Cat	1	<p>The student is able to:</p> <ul style="list-style-type: none"> <li>- Read information from a bar graph.</li> <li>- Identify and tell the title of a bar graph.</li> <li>- Predict the outcome of an experiment using probability words such as impossible, possible, certain, likely and unlikely.</li> <li>- Explain the reasons for the predictions made.</li> </ul>
Animal	Count												
COW	3												
Horse	2												
Sheep	5												
Hen	3												
Cat	1												
<b>Comments and Marks</b>													
<p>Strengths:</p>  <p>Areas of Need:</p>  <p>Follow up Steps:</p>  <p style="text-align: center;">Teacher's Signature and Date:</p>													

#### Summary of the Summative Assessment for Chapter 9

CA marks from Chapter 9 (Marks out of 10): \_\_\_\_\_





## Summative Assessment Recording Sheet

Student Name: \_\_\_\_\_ Roll no.: \_\_\_\_ Section: \_\_\_\_

### CHAPTER 10 MEASURING MASS, CAPACITY AND TIME

*Interview-based Performance Task (Please refer the Introduction to the Teacher's Guide for Class 2 for the marking scheme while using the Interview-based Performance Task.)*

Task and Interview prompts	Key concepts and skills to look for
<p>Have some rice (or sand), an empty plastic bag, a pan balance, and 1 kg weight (or 1 kg mass such as a package of salt). Tell/ask the student:  <b>Put about a kilogram of rice in this plastic bag. How do you know that it is about 1 kilogram? How can you measure it so that you have exactly 1 kilogram of rice here? Can you measure 2 kilograms of rice in another plastic bag?</b></p> <p>Have a container which has a capacity of 1 litre such as a mineral water bottle, a larger container, a bucket of water, a jug and a funnel if possible. Tell the student that the bottle has a capacity of 1 litre. Ask/tell the student:  <b>What would be the capacity of this (larger) container? How can you measure it? What is the capacity of it?</b></p> <p>Draw a diagram of an analog clock showing a time such as half past 3 o'clock. Ask/tell the student:  <b>What time does this clock show? What is another way of saying this time?</b></p>	<p>The student is able to:</p> <ul style="list-style-type: none"> <li>- Estimate a mass of 1 kilogram reasonably.</li> <li>- Measure mass in kilograms.</li> <li>- Predict or estimate the capacity of a container in litres reasonably.</li> <li>- Measure the capacity of a container in litres.</li> <li>- Describe or express the capacity of a container in litres appropriately.</li> <li>- Read the times from and analog clock.</li> <li>- Tell a time in terms of “__ minutes past __ o'clock”.</li> <li>- Tell the time in digital clock format such as “two thirty” for 2:30.</li> </ul>
<p><b>Comments and Marks</b></p> <p>Strengths:</p>   <p>Areas of Need:</p>   <p>Follow up Steps:</p>          <p style="text-align: center;">Teacher's Signature and Date:</p>	

#### Summary of the Summative Assessment for Chapter 10

CA marks from Chapter 10 (Marks out of 10): \_\_\_\_\_

