

*Teacher's Guide to*  
***Understanding Mathematics***  
*Textbook for Class VI*



ཉེས་རིག

Department of School Education  
Ministry of Education and Skills Development  
Royal Government of Bhutan

Published by:  
Department of School Education (DSE)  
Ministry of Education and Skills Development (MoESD)  
Royal Government of Bhutan  
Tel: +975-2-332885/332880

Copyright © 2023 DSE, MoESD, Thimphu

### **ALL RIGHTS RESERVED**

No part of this book may be reproduced in any form without permission from the DSE, MoESD, Thimphu.

## **ACKNOWLEDGEMENTS**

### **Advisors**

Dasho Dr. Pema Thinley, Secretary, Ministry of Education  
Tshewang Tandin, Director, Department of School Education, Ministry of Education  
Yangka, Director for Academic Affairs, Royal University of Bhutan  
Karma Yeshey, Chief Curriculum Officer, CAPSD

### **Research, Writing, and Editing**

One, Two, ..., Infinity Ltd., Canada

### **Authors**

Marian Small  
Wendi Morrison

### **Reviewers**

Tara Small

### **Editors**

Jackie Williams  
Carolyn Wagner

### **Bhutanese Reviewers**

Sonam Dorji M	Bjishong MSS, Gasa
Dorji Penjor	Logodama PS, Punakha
Padam P Kafley	Tsaphel LSS, Haa
Kuenga Loday	Umling CPS, Sarpang
Dorji Wangdi	Panbang LSS, Zhemgang
Pelden Dorji	Moshi CPS, Trashigang
Radhika Chettri	Tencholing PS, Wangdue
R.K. Chettri	Tencholing PS, Wangdue
Devika Gurung	Mongar LSS, Mongar
Kinley Wangchuk	Norbugang CPS, Pemagatsel
Namgyel Dhendup	Patala PS, Tsirang
Karchung Dorji	Tangmachu PS, Lhuntse
Tshering Yangzom	RinchenKunphen PS, Thimphu
Rupak Sharma	Khasadrapchu MSS, Thimphu
Mindu Gyeltshen	EMSSD, Thimphu
Ugyen Lhadon	Gaupel LSS, Paro
Arjun Chettri	PCE, Paro
Lobzang Dorji	CAPSD, Paro

### **Coordination**

Karma Yeshey and Lobzang Dorji, Curriculum Officers, CAPSD

The Ministry of Education wishes to thank

- all teachers in the field who have given support and feedback on this project
- the World Bank, for ongoing support for School Mathematics Reform in Bhutan
- Nelson Publishing Canada, for its publishing expertise and assistance

1st edition 2008  
Reprint 2024

ISBN: 99936-0-326-0

# CONTENTS

**FOREWORD vii**

**INTRODUCTION ix**

How Mathematics Has Changed **ix**

The Design of the Student Textbook **x**

The Design of the Teacher's Guide **xiv**

Assessing Mathematical Performance **xvii**

The Classroom Environment **xviii**

Mathematical Tools **xx**

The Student Notebook **xx**

**CLASS VI CURRICULUM**

Strand A: Number **xxi**

Strand B: Operations **xxii**

Strand C: Patterns and Relationships **xxiv**

Strand D: Measurement **xxv**

Strand E: Geometry **xxvi**

Strand F: Data Management **xxvii**

Strand G: Probability **xxviii**

**UNIT 1 FRACTIONS AND DECIMALS**

Getting Started **4**

*Chapter 1 Relating Fractions*

**1.1.1** Relating Mixed Numbers to Improper Fractions **7**

**1.1.2** Comparing and Ordering Fractions **10**

**1.1.3** EXPLORE: Adding and Subtracting Fractions **13**

**1.1.4** Adding Fractions **15**

CONNECTIONS: Fractions Between Fractions **18**

**1.1.5** Subtracting Fractions **19**

*Chapter 2 Relating Fractions to Decimals*

**1.2.1** Naming Decimals as Fractions **22**

GAME: Fraction Match **24**

**1.2.2** Naming Fractions as Decimals **25**

UNIT 1 Revision **27**

UNIT 1 Test **29**

UNIT 1 Performance Task **31**

UNIT 1 Blackline Masters **34**

## **UNIT 2 GEOMETRY**

Getting Started **44**

### ***Chapter 1 2-D Geometry: Transformations***

**2.1.1** Rotations **46**

**2.1.2** Rotational Symmetry **50**

**2.1.3** Combining Transformations **53**

GAME: Transformation Challenge **56**

**2.1.4** EXPLORE: Tessellations **57**

CONNECTIONS: Escher-type Tessellations **60**

### ***Chapter 2 2-D Geometry: Shapes and Properties***

**2.2.1** Measuring Angles **61**

**2.2.2** Bisectors **64**

**2.2.2** EXPLORE: Sorting Quadrilaterals **68**

GAME: Go Fish **70**

### ***Chapter 3 3-D Geometry***

**2.3.1** EXPLORE: Planes of Symmetry **71**

**2.3.2** EXPLORE: Cross-sections **73**

**2.3.3** Interpreting Orthographic Drawings **75**

**2.3.4** Creating Orthographic Drawings **78**

UNIT 2 Revision **81**

UNIT 2 Test **84**

UNIT 2 Assessment Interview **87**

UNIT 2 Performance Task **88**

UNIT 2 Blackline Masters **91**

## **UNIT 3 DECIMAL COMPUTATION**

Getting Started **110**

### ***Chapter 1 Multiplication***

**3.1.1** Estimating a Product **113**

**3.1.2** Multiplying a Decimal by a Whole Number **115**

**3.1.3** Multiplying Decimals **118**

GAME: Target 10 **121**

### ***Chapter 2 Division***

**3.2.1** Estimating a Quotient **122**

**3.2.2** Dividing a Decimal by a Whole Number **125**

**3.2.3** EXPLORE: Dividing by 0.1, 0.01, and 0.001 **127**

**3.2.4** Dividing Decimals **129**

### ***Chapter 3 Combining Operations***

**3.3.1** Order of Operations **133**

**3.3.2** Solving a Problem Using all Four Operations **136**

CONNECTIONS: Decimal Magic Squares **138**

UNIT 3 Revision **139**  
UNIT 3 Test **141**  
UNIT 3 Performance Task **144**  
UNIT 3 Blackline Masters **146**

## **UNIT 4 MEASUREMENT**

Getting Started **150**

### ***Chapter 1 Area***

**4.1.1** Area of a Parallelogram **152**

CONNECTIONS: Changing a Parallelogram **155**

**4.1.2** Area of a Triangle **156**

GAME: Grid Fill **158**

**4.1.3** EXPLORE: Relating Areas **159**

### ***Chapter 2 Volume***

**4.2.1** Volume of a Rectangular Prism **162**

**4.2.2** Relating Volume to Capacity **165**

### ***Chapter 3 Time and Mass***

**4.3.1** The 24-hour Clock System **168**

**4.3.2** The Tonne **170**

UNIT 4 Revision **172**

UNIT 4 Assessment Interview **173**

UNIT 4 Test **174**

UNIT 4 Performance Task **176**

UNIT 4 Blackline Masters **178**

## **UNIT 5 RATIO, RATE, AND PERCENT**

Getting Started **182**

### ***Chapter 1 Ratio and Rate***

**5.1.1** Introducing Ratios **185**

**5.1.2** Equivalent Ratios **188**

**5.1.3** Comparing Ratios **191**

**5.1.4** EXPLORE: Similarity **193**

**5.1.5** Introducing Rates **195**

### ***Chapter 2 Percent***

**5.2.1** Introducing Percent **197**

**5.2.2** Representing a Percent in Different Ways **200**

GAME: Ratio Match **201**

**5.2.3** EXPLORE: Writing a Fraction as a Percent **202**

CONNECTION: Map Scales **204**

UNIT 5 Revision **205**

UNIT 5 Test **207**

UNIT 5 Performance Task **209**

UNIT 5 Blackline Masters **211**

## **UNIT 6 NUMBER RELATIONSHIPS**

Getting Started **217**

### ***Chapter 1 Large Whole Numbers***

**6.1.1 EXPLORE: Solving Problems With Large Numbers 219**

**6.1.2 Place Value With Large Whole Numbers 221**

**6.1.3 Renaming Numbers 224**

### ***Chapter 2 Decimals and Integers***

**6.2.1 Place Value With Decimals 227**

**6.2.2 Comparing and Ordering Decimals 229**

**6.2.3 Introducing Integers 231**

### ***Chapter 3 Number Theory***

**6.3.1 Prime Numbers 233**

CONNECTIONS: The Sieve of Eratosthenes **235**

**6.3.2 EXPLORE: Square and Triangular Numbers 236**

CONNECTIONS: Triangular Numbers as Products **237**

**6.3.3 EXPLORE: Factors 238**

GAME: Down to Prime **239**

**6.3.4 Common Factors 240**

UNIT 6 Revision **243**

UNIT 6 Test **245**

UNIT 6 Performance Task **247**

UNIT 6 Blackline Masters **249**

## **UNIT 7 DATA AND PROBABILITY**

Getting Started **256**

### ***Chapter 1 Collecting Data***

**7.1.1 Choosing a Sample 259**

**7.1.2 EXPLORE: Sample Size 261**

### ***Chapter 2 Graphing Data***

**7.2.1 Double Bar Graphs with Intervals 263**

**7.2.2 Stem and Leaf Plots 267**

**7.2.3 Line Graphs 271**

CONNECTIONS: Telling a Story about a Graph **275**

**7.2.4 Coordinate Graphs 276**

GAME: Four in a Line **279**

### ***Chapter 3 Statistics and Probability***

**7.3.1 Mean, Median, and Mode 280**

**7.3.2 Theoretical Probability 282**

UNIT 7 Revision **285**

UNIT 7 Test **289**

UNIT 7 Performance Task **292**

UNIT 7 Blackline Masters **296**



MINISTER

ROYAL GOVERNMENT OF BHUTAN

ཤེས་རིག་ལྷན་ཁག།  
MINISTRY OF EDUCATION  
THIMPHU :BHUTAN

*Cultivating the Grace of Our Mind*



December 15, 2008

**Foreword**

I am at once awed and fascinated by the magic and potency of numbers. I am amazed at the marvel of the human mind that conceived of fantastic ways of visualizing quantities and investing them with enormous powers of representation and symbolism. As my simple mind struggles to make sense of the complexities that the play of numbers and formulae presents, I begin to realize, albeit ever so slowly, that, after all, all mathematics, as indeed all music, is a function of forming and following patterns and processes. It is a supreme achievement of the human mind as it seeks to reduce apparent anomalies and to discover underlying unity and coherence.

Abstraction and generalization are, therefore, at the heart of meaning-making in Mathematics. We agreed, propped up as by convention, that a certain figure, a sign, or a symbol, would carry the same meaning and value for us in our attempt to make intelligible a certain mass or weight or measure. We decided that for all our calculations, we would allow the signifier and the signified to yield whatever value would result from the tension between the quantities brought together by the nature of their interaction.

One can often imagine a mathematical way of ordering our surrounding and our circumstance that is actually finding a pattern that replicates the pattern of the universe – of its solid and its liquid and its gas. The ability to engage in this pattern-discovering and pattern-making and the inventiveness of the human mind to anticipate the consequence of marshalling the power of numbers give individuals and systems tremendous privilege to the same degree which the lack of this facility deprives them of.

Small systems such as ours cannot afford to miss and squander the immense power and privilege the ability to exploit and engage the resources of Mathematics have to present. From the simplest act of adding two quantities to the most complex churning of data, the facility of calculation can equip our people with special advantage and power. How intelligent a use we make of the power of numbers and the precision of our calculations will determine, to a large extent, our standing as a nation.

I commend the good work done by our colleagues and consultants on our new Mathematics curriculum. It looks current in content and learner-friendly in presentation. It is my hope that this initiative will give the young men and women of our country the much-needed intellectual challenge and prepares them for life beyond school. The integrity of the curriculum, the power of its delivery, and the absorptive inclination of the learner are the eternal triangle of any curriculum. Welcome to Mathematics.

Imagine the world without numbers! Without the facility of calculation!

Tashi Delek.

Thakur S Powdyel.





## HOW MATHEMATICS HAS CHANGED

Mathematics is a subject with a long history. Although newer mathematical ideas are always being created, much of what your students will be learning is mathematics that has been known for hundreds of years, if not longer.

There are some changes in the content that you will teach. It may be that the content is new to your class, but not to your curriculum. Or, it may be new to your curriculum. For example, work on isometric drawings in geometry is new.

What you may notice most is a change in the approach to mathematics. Worldwide, there is now a greater emphasis on the need for students to understand the mathematics they learn rather than to memorize rote procedures. There are many reasons for this.

*Worldwide, there is now a greater emphasis on the need for students to understand the mathematics they learn rather than to memorize rote procedures.*

- In the long run, it is very unlikely that students will remember the mathematics they learn unless it is meaningful. It is much harder to memorize “nonsense” than something that relates to what they already know.
- Some approaches to mathematics have not been successful; there are many adults who are not comfortable with mathematics even though they were successful in school.

In this new program, you will find many ways to make mathematics more meaningful.

- We will always talk about why something is true, not simply that it is true. For example, the reason why you multiply decimals just like whole numbers and then place the appropriate number of decimal points is explained, not just stated.
- Mathematics should be taught using contexts that are meaningful to the students. They can be mathematical contexts or real-world contexts. These contexts will help students see and appreciate the value of mathematics

*It is important always to talk about why something is true, not simply that it is true.*

For example:

- In Unit 3 (Decimal Computation), a task with a real-world context involves estimating the number of cases of bottled water needed for an archery competition.
- A task with a broader context in Unit 6 (Number Relationships) involves comparing Bhutan to Australia.

The area of Bhutan is about 0.0061 of the area of Australia.  
The population of Bhutan is about 0.0369 of the population of Australia.

- a) Which decimal is greater?
- b) What does that tell you?

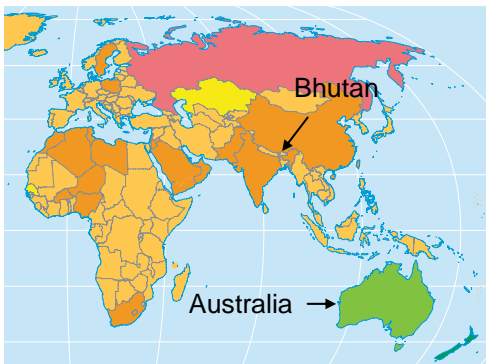

- When discussing mathematical ideas, we expect students to use the processes of problem solving, communication, reasoning, making connections (connecting mathematics to the real world and connecting mathematical topics to each other) and representation (representing mathematical ideas in different ways, such as manipulatives, graphs, and tables). For example, students use grids to represent decimal thousandths. This will help them visualize the relationship between thousandths, hundredths, and tenths.
- There is an increased emphasis on problem solving because the reason we learn mathematics is to solve problems. Once students are adults, they are not told when to factor or when to multiply; they need to know how to apply those skills to solve certain problems. Students will be given opportunities to make decisions about which concepts and skills they need in certain situations.

A significant amount of research evidence has shown that these more meaningful approaches work. Scores on international tests are higher when the emphasis is on higher level thinking and not only on the application of skills.

*We expect students to use the processes of problem solving, communication, reasoning, making connections, and representation.*

*Scores on international tests are higher when the emphasis is on higher level thinking and not only on the application of skills.*

## THE DESIGN OF THE STUDENT TEXTBOOK

Each unit of the textbook has the following features:

- a *Getting Started* to review prerequisite content
- two or three chapters, which cluster the content of the unit into sections that contain related content
- regular lessons and at least one *Explore* lesson
- a *Game*
- at least one *Connections* feature
- a *Unit Revision*

### Getting Started

There are two parts to the *Getting Started*. They are designed to help you know whether the students are missing critical prerequisites and to remind students of knowledge and terminology they have already learned that will be useful in the unit.

- The *Use What You Know* section is an activity that takes 20 to 30 minutes. Students are expected to work in pairs or in small groups. Its purpose is consistent with the rest of the text's approach, that is, to engage students in learning by working through a problem or task rather than being told what to do and then just carrying it through.
- The *Skills You Will Need* section is a more straightforward review of required prerequisite skills for the unit. This should usually take about 20 to 30 minutes.

*The Getting Started is designed to help you know whether the students are missing critical prerequisites and to remind students of knowledge and terminology they will need for the unit.*

### Regular Lessons

- Each lesson might be completed in one or two hours (i.e., one or two class periods), although some are shorter. The time is suggested in this *Teacher's Guide*, but it is ultimately at your discretion.
- Lessons are numbered #.#.#. The first number tells the unit, the second number the chapter, and the third number the lesson within the chapter. For example, Lesson 4.2.1 is Unit 4, Chapter 2, Lesson 1.

*Lessons are numbered #.#.#. The first number tells the unit, the second number the chapter, and the third number the lesson within the chapter.*

- Each lesson is divided into five parts:
  - A *Try This* task or problem
  - The exposition (the main points of the lesson)
  - A question that revisits the *Try This* task, called *Revisiting the Try This* in this guide
  - one or more *Examples*
  - *Practising and Applying* questions

### *Try This*

- The *Try This* task is in a shaded box, like the one below from Unit 3, lesson 3.1.2 on page 73.

#### **Try This**

Lobzang can run 100 m in 12.4 s.

**A.** About how long would it take him to run 300 m at that speed? Explain how you estimated.



*The Try This is a brief task or problem that students complete in pairs or small groups to motivate new learning.*

- The *Try This* is a brief task or problem that students complete in pairs or small groups. It serves to motivate new learning. Students can do the *Try This* without the new concepts or skills that are the focus of the lesson, but the problem is related to the new learning. It should be completed in 5 to 10 minutes. The reason to start with a *Try This* is that we believe students should do some mathematics independently before you intervene.
- The answers to the *Try This* questions are not found in the back of the student book (but they are in this *Teacher's Guide*).

*The exposition presents the main concepts and skills of the lesson and is taught in different ways, as suggested in this guide.*

### *The Exposition*

- The exposition presents the main concepts and skills of the lesson. Examples are often included to clarify the points being made.
- You will help the students through the exposition in different ways (as suggested in this *Teacher's Guide*). Sometimes you will present the ideas first, using the exposition as a reference. Other times students will work through the exposition independently, in pairs, or in small groups.
- Key mathematical terms are introduced and described in the exposition. When a key term first appears in a unit of the textbook, it is highlighted in **bold type** to indicate that it is found in the glossary (at the back of the student textbook).
- Students are not expected to copy the exposition into their notebooks either directly from the book or from your recitation.

### *Revisiting the Try This*

- The *Revisiting the Try This* question follows the exposition and appears in a shaded lozenge, like this example from Unit 3, lesson 3.1.2 on page 74.

**B. i)** Exactly how long would it take Lobzang to run 300 m at a speed of 100 m in 12.4 s?  
**ii)** How does your exact answer compare to your estimate from **part A**?



- The *Revisiting the Try This* question links the *Try This* task or problem to the new ideas presented in the exposition. This is designed to build a stronger connection between the new learning and what students already understand.

*The Revisiting the Try This question links the Try This task to the new ideas presented in the exposition.*

### Examples

- The *Examples* are designed to provide additional instruction by modelling how to approach some of the questions students will meet in *Practising and Applying*. Each example is a bit different from the others so that students have multiple models from which to work.
- The *Examples* show not only the formal mathematical work (in the left hand *Solution* column), but also student reasoning (in the right hand *Thinking* column). This model should help students learn to think and communicate mathematically. Photographs of students are used to further reinforce this notion.
- Some of the *Examples* present two different solutions. The example below, from Unit 3, lesson 3.1.3 on page 79, shows two possible ways to approach the task, *Solution 1* and *Solution 2*.

*The Examples model how to approach some of the questions students will meet in Practising and Applying*

<b>Example 3 Multiplying Decimals in Parts</b>	
Calculate $2.2 \times 4.15$ .	
<b>Solution 1</b> $2.2 = 2 + 0.2$ $2.2 \times 4.15 = (2 \times 4.15) + (0.2 \times 4.15)$ $2 \times 4.15 = 8.30$ $0.2 \times 4.15 = 0.1 \times (2 \times 4.15)$ $\quad = 0.1 \times 8.30$ $\quad = 0.830$ $8.30 + 0.830 = 9.130$ $2.2 \times 4.15 = 9.130$	<b>Thinking</b> • I knew that 2.2 groups of 4.15 was 2 groups of 4.15 plus another 0.2 of a group of 4.15, so I calculated them separately and then added them together. 
<b>Solution 2</b> $\begin{array}{r} 1 \\ \frac{1}{2} \\ 415 \\ \times 22 \\ \hline 830 \\ + 8300 \\ \hline 9130 \end{array}$ $2.2 \times 4.14$ is about $2 \times 4 = 8$ $2.2 \times 4.15 = 9.130$	<b>Thinking</b> • I multiplied 415 by 22 and then estimated to figure out where the decimal point would be — because $2 \times 4 = 8$ , then the decimal in 9130 must be after the 9. 

*The Examples show the formal mathematical work in the Solution column and model student reasoning in the Thinking column. This model should help students learn to think and communicate mathematically.*

- The treatment of *Examples* varies and is discussed in the *Teacher's Guide*. Sometimes the students work through these independently, sometimes they work in pairs or small groups, and sometimes you are asked to lead them through some or all of the examples.
- A number of the questions in the *Practising and Applying* section are modelled in the *Examples* to make it more likely that students will be successful.

### *Practising and Applying*

- Students work on the *Practising and Applying* questions independently, with a partner, or in a group, using the exposition and *Examples* as references.
- The questions usually start like the work in the *Examples* and get progressively more conceptual, with more explanations and more problem solving required later in the exercise set.
- The last question in the section always brings closure to the lesson by asking students to summarize the main learning points. This question could be done as a whole class.

### **Explore Lessons**

- *Explore* lessons provide an opportunity for students to work in pairs or small groups to investigate some mathematics in a less directed way. Often, but not always, the content is revisited more formally in a regular lesson immediately before or after the *Explore* lesson. The *Teacher's Guide* indicates whether the *Explore* lesson is optional or core.
- There is no exposition or teacher lecture in an *Explore* lesson, so the parts of the regular lesson are not there. Instead, a problem or task is posed and students work through it by following a sequence of questions or instructions that direct their investigation.
- The answers for these lessons are not found in the back of the textbook, but are found in this *Teacher's Guide*.

### **Connections**

- The *Connections* is an optional feature that relates the content of the unit to something else.
- There are always one or more *Connections* features in a unit. The placement of a *Connections* feature in a unit is not fixed; it depends on the content knowledge required. Sometimes it will be early in the unit and sometimes later.
- The *Connections* feature always gives students something to do beyond simply reading it.
- Students usually work in pairs or small groups to complete these activities.

### **Game**

- There is at least one *Game* per unit.
- The *Game* provides an enjoyable way to practise skills and concepts introduced in the unit.
- Its placement in the unit is based on where it makes most sense in terms of the content required to play the *Game*.
- In most *Games* students work in pairs or small groups, as indicated in the instructions.
- The required materials and rules are listed in the student book. Usually there is a sample shown to make sure that students understand the rules.
- Most *Games* require 15 to 20 minutes, but students can often benefit from playing them more than once.



Fraction Match game from UNIT 1

*Students work on the Practising and Applying questions independently, with a partner, or in a group, using the exposition and Examples as references.*

*Explore lessons provide an opportunity for students to work with a partner or in small groups to investigate some mathematics in a less directed way.*

*The Connections feature takes many forms. Sometimes it is a relevant and interesting historical note. Sometimes it relates the mathematical content of a unit to the content of a different unit. Other times it relates the mathematical content to a real world application.*

*The Game provides an enjoyable way to practise skills and concepts introduced in the unit.*

## Unit Revision

- The *Unit Revision* provides an opportunity for review for students and for you to gather informal assessment data. *Unit Revisions* review all lesson content except the *Getting Started* feature, which is based on previous class content. There is always a mixture of skill, concept, and problem solving questions.
- The order of the questions in the *Unit Revision* generally follows the order of the lessons in the unit. Sometimes, if a question reflects more than one lesson, it is placed where questions from the later lesson would appear.
- Students can work in pairs or on their own, as you prefer.
- The *Unit Revision*, if done in one sitting, requires one or more hours. If you wish, you might break it up and assign some questions earlier in the unit and some questions later in the unit.

*The Unit Revision provides an opportunity for review for students and allows you to gather informal assessment data.*

## Glossary

- At the end of the student textbook, there is a glossary of key mathematical terminology introduced in the units. When new terms are introduced in the units, they are in **bold** type. All of these terms are found in the glossary.
- The glossary also contains important mathematical terms from previous classes that students might need to refer to.
- In addition, there is a set of instructional terms commonly used in the *Practising and Applying* questions (for example, explain, predict, ...) along with descriptions of what those terms require the student to do.

*The glossary contains key mathematical terminology introduced in the units, important terms from previous classes, and a set of instructional terms.*

## Answers

- Answers to most numbered questions are provided in the back of the student textbook. In most cases, only the final answers are shown, not full solutions and explanations. For example, if students are asked to solve a problem and then "Show your work" or "Explain your thinking", only the final answer to the problem is included, not the work or the reasoning.
- There is often more than one possible answer. This is indicated by the phrase *Sample Response*.
- Full solutions to the questions and explanations that show reasoning are provided in this *Teacher's Guide*, as are the answers to the lettered questions (such as A or B) in the *Try This* and the *Explore* lessons. When an answer or any part of an answer is enclosed in square brackets, this indicates that it has been omitted from the answers at the back of the student textbook.

*The answers to most of the numbered questions are found in the back of the student book. This Teacher's Guide contains a full set of answers.*

## THE DESIGN OF THE TEACHER'S GUIDE

The *Teacher's Guide* is designed to complement and support the use of the student textbook.

- The sequencing of material in the guide is identical to the sequencing in the student textbook.
- The elements in the *Teacher's Guide* for each unit include:
  - a *Unit Planning Chart*
  - *Math Background* for the unit
  - a *Rationale for Teaching Approach*
  - support for each lesson
  - a *Unit Test*
  - a *Performance Task*
  - an *Assessment Interview* (Units 2 and 4)

*The Teacher's Guide is designed to complement and support the use of the student textbook.*

The support for each lesson includes:

- *Curriculum outcomes* covered in that lesson
- *Outcome relevance* (*Lesson relevance* in the case of optional *Explore* lessons)
- *Pacing* in terms of minutes or hours
- *Materials* required to teach the lesson
- *Prerequisites* that the lesson assumes students possess
- *Main Points to be Raised* explicitly in the lesson
- suggestions for working through the parts of the lesson
- *Suggested assessment* for the lesson
- *Common errors* to be alert for
- *Answers*, often with more complete solutions than are found in the student text
- suggestions for *Supporting Students* who are struggling and/or for enrichment

## Unit Planning Chart

This chart provides an overview of the unit and indicates, for each lesson, which curriculum outcomes are being covered, the pacing, the materials required, and suggestions for which questions to use for formative assessment.

*The Unit Planning Chart provides an overview of the unit.*

## Math Background and Rationale for Teaching Approach

This explains the organization of the unit or provides some background for you that you might not have, particularly in the case of less familiar content. In addition, there is generally an indication of why the material is approached the way it is.

*This section provides information about the math behind the unit, and an explanation of why the math is approached the way it is.*

## Regular Lesson Support

- Suggestions for grouping and instructional strategies are offered under the headings *Try This*, *Revisiting the Try This*, *The Exposition — Presenting the Main Ideas*, *Using the Examples*, and *Practising and Applying — Teaching Tips*.
- *Common errors* are sometimes included. If you are alert for these and apply some of the suggested remediation, it is less likely that students will leave the lessons with mathematical misunderstandings.
- A number of *Suggested assessment questions* are listed for each lesson. This is to emphasize the need to collect data about different aspects of the students' performance — sometimes the ability to apply skills, sometimes the ability to solve problems or communicate mathematical understanding, and sometimes the ability to show conceptual understanding.
- It is not necessary to assign every *Practising and Applying* question to each student, but they are all useful. You should go through the questions and decide where your emphasis will be. It is important to include a balance of skills, concepts, and problem solving. You might use the *Suggested assessment questions* as a guide for choosing questions to assign.
- You may decide to use the last *Practising and Applying* question to focus a class discussion that revisits the main ideas of the lesson and to bring closure to the lesson.

*Regular lesson support includes grouping and instructional strategies, alerts for common errors, suggestions for assessment, and teaching tips.*

## Explore Lesson Support

- As with regular lessons, for *Explore* lessons there is an indication of the curriculum outcomes being covered, the relevance of the lesson, and whether the lesson is optional or essential.
- Because the style of the lesson is different, the support provided is different than for the regular lessons. There are suggestions for grouping the students for the exploration, a list of *Observe and assess* questions to guide your informal formative assessment, and *Share and reflect* ideas on how to consolidate and bring closure to the exploration.

*Because the style of an Explore lesson is different than a regular lesson, the support provided in the Teacher's Guide is also different.*

## Unit Test

A pencil-and-paper unit test is provided for each unit. It is similar to the unit revision, but not as long. If it seems that the test might be too long (for example, if students would require more than one class period to complete it) some questions may be omitted. It is important to balance the items selected for the test to include questions involving skills, concepts, and problem solving, and to include at least one question requiring mathematical communication.

*If the test seems too long, some questions may be omitted but it is important to ensure a balance of questions involving skills, concepts, problem solving, and communication.*

## Performance Task

- The *Performance Task* is designed as a summative assessment task. Performance on the task can be combined with performance on a *Unit Test* to give a mark for a student on a particular unit.
- The task requires students to use both problem solving and communication skills to complete it. Students have to make mathematical decisions to complete the task.
- It is not appropriate to mark a performance task using percentages or numerical grades. For that reason, a rubric is provided to guide assessment. There are four levels of performance that can be used to describe each student's work on the task. A level is assigned for each different aspect of the task and, if desired, an overall profile can be assigned. For example, if a student's performance is level 2 on most of the aspects of the task, but level 3 on one aspect, an overall profile of level 2 might be assigned.
- A sample solution is provided for each task.

*The Performance Task is designed as a summative assessment task that can be combined with a student's performance on the Unit Test to give an overall mark.*

## Unit Assessment Interviews

- Selected units (2 and 4) provide a structure for an interview that can be used with one or several students to determine their understanding of the outcomes.
- Interviews are a good way to collect information about students because they allow you to interact with the students and to follow up if necessary. Interviews are particularly appropriate for students whose performance is inconsistent or who do not perform well on written tests, but who you feel really do understand the content.
- You may use the data you collect in combination with class work or even a unit test mark.

*Interviews are a good way to collect information about students, since interviews allow you to interact with the students and to follow up if necessary.*



# ASSESSING MATHEMATICAL PERFORMANCE

## Forms of Assessment

It is important to consider both formative (continuous) and summative assessment.

### *Formative*

- Formative assessment is observation to guide further instruction. For example, if you observe that a student does not understand an idea, you may choose to re-teach that idea to that student using a different approach.
- Formative assessment opportunities are provided through
  - prerequisite or diagnostic assessment in the *Getting Started*
  - suggestions for assessment questions in each regular lesson
  - questions that might be asked while students work on the *Try This* or during an *Explore* lesson
  - the *Unit Revision*
  - the unit *Assessment Interview* (for the units with interviews)
- Formative assessment can be supplemented by
  - everyday observation of students' mathematical performance
  - formal or informal interviews to reveal students' understanding
  - journals in which students comment on their mathematical learning
  - short quizzes
  - projects
  - a portfolio of work so students can see their progress over time, for example, in problem solving or mathematical communication (see *Portfolios* below)

*Formative assessment is observation to guide further instruction.*

### *Summative*

- Summative assessment is used to see what students have learned and is often used to determine a mark or grade.
- Summative assessment opportunities are provided through
  - the *Unit Test*
  - the *Performance Task*
  - the *Assessment Interview*
- Summative assessment can be supplemented with
  - short quizzes
  - projects
  - a portfolio that is assessed with respect to progress in, for example, problem solving or communication

*Summative assessment is used to see what students have learned and is often used to determine a mark.*

### *Portfolios*

One of the advantages of using portfolios for assessment is that students can observe their own growth over time, leading to greater confidence. In each unit, the section on math background identifies items that pertain to the various mathematical processes. The portfolio could be made up of student work items related to one of the mathematical processes: problem solving, communication, reasoning, or representation.

*One of the advantages of using portfolios for assessment is that students can observe their own growth over time, leading to greater confidence.*

### **Assessment Criteria**

- It is right and fair to inform students about what will be assessed and how it will be assessed. For example, students should know whether the intent of a particular assessment task is to focus on application or on problem solving.

*It is right and fair to inform students about what will be assessed and how it will be assessed.*

- A student's mark and all assessments should reflect the curriculum outcomes for Class VI. The proportions of the mark assigned for each unit should reflect both the time spent on the unit and the importance of the unit. The modes of assessment used for a particular unit should be appropriate for the content. For example, if the unit focuses mostly on skills, the main assessment might be a paper-and-pencil test or quizzes. If the unit focuses on concepts and application, more of the student's mark should come from activities like performance tasks.
- The focus of this curriculum is not on procedures for their own sake but on a conceptual understanding of mathematics so that it can be applied to solve problems. Procedures are important too, but only in the context of solving problems. All assessment should balance procedural, conceptual, and problem solving items, although the proportions will vary in different situations.
- Students should be informed whether a test is being marked numerically, using letter grades, or with a rubric. If a rubric is being used, then it should be shared with students before they begin the task to which it is being applied.

*The modes of assessment used for a particular unit should be appropriate for the content.*

*All assessment should balance procedural, conceptual, and problem solving items, although the proportions may vary in different situations.*

### **Determining a Mark**

- In determining a student's mark, you can use the tools described above along with other information, such as work on a project or poster. It is important to remember that the mark should, as closely as possible, reflect student competence with the mathematical outcomes of the course. The mark should not reflect behaviour, neatness, participation, and other non-mathematical aspects of the student's learning. These are important to assess as well, but not as part of the mathematics mark.
- In looking at a student's mathematics performance, the most recent data might be weighted more heavily. For example, suppose a student does poorly on some of the quizzes given early in Unit 1, but you later observe that he or she has a better understanding of the material in the unit. You might choose to give the early quizzes less weight in determining the student's mark for the unit.
- At present, you are required to produce a numerical mark for a student, but that should not preclude your use of rubrics to assess some mathematical performance. One of the values of rubrics is their reliability. For example, if a student performs at level 2 on a particular task one day, he or she is very likely to perform at the same level on that task another day. On the other hand, a student who receives a test mark of 45 one day might have received a mark of 60 on a different day if one question on the test had changed or if he or she had read an item more carefully.
- You can combine numerical and rubric data using your own judgment. For example, if a student's marks on tests average 50%, but the rubric performance is higher, for example, level 3, it is fair and appropriate to use a higher average for that student's class mark.

*It is important to remember that the mark should reflect student competence with the mathematical outcomes of the course and not behaviour, neatness, participation, and so on.*

## **THE CLASSROOM ENVIRONMENT**

This new curriculum requires a change in the classroom environment to include more pair and group work and an increased emphasis on communication. It is only in this way that students will really become engaged in mathematical thinking instead of being spectators.

- In every lesson, students should be engaged in some pair or small group work (for the *Try This*, selected *Practising and Applying* questions, or during an *Explore* lesson).
- Students should be encouraged to communicate with each other to share responses that are different from those offered by other students or from the responses you might expect. Communication involves not only talking and writing, but also listening and reading.

*This new curriculum requires a change in the classroom environment to include more pair and group work and an increased emphasis on communication.*

## Pair and Group Work

- There are many reasons why students should be working in pairs or groups, including
  - to ensure that students have more opportunities to communicate mathematically (instead of competing with the whole class for a turn to talk)
  - to make it easier for them to take the risk of giving an answer they are not sure of (rather than being embarrassed in front of so many other people if they are incorrect)
  - to see the different mathematical viewpoints of other students
  - to share materials more easily
- Sometimes students can work with the students who sit near them, but other times you might want to form the groups so that students who are struggling are working together. Then you can help them while the other students move forward. Students who need enrichment can also work together so that you can provide an extra challenge for them all at once.



- For students who are not used to working in pairs or groups, you should set down rules of behaviour that require them to attend to the task and to participate fully. You need to avoid a situation where four students are working together, but only one of them is really doing the work. You might post Rules for Group Work, as shown here to the right.
- Once students are used to working in groups, you might sometimes be able to base assessment on group performance rather than on individual performance.

### Rules for Group Work

- Make sure you understand all the work produced by the group.
- If you have a question, ask your group members first, before asking your teacher.
- Find a way to work out disagreements without arguing.
- Listen to and help others.
- Make sure everyone is included and encouraged.
- Speak just loudly enough to be heard.

## Communication

Students should be communicating regularly about their mathematical thinking. It is through communication that they clarify their own thinking as well as show you and their classmates what they do or do not understand. When they give an answer to a question, you can always be asking questions like, *How did you get that? How do you know? Why did you do that next?*

- Communication is practised in small group settings, but is also appropriate when the whole class is working together.
- Students will be reluctant to communicate unless the environment is risk-free. In other words, if students believe that they will be reprimanded or made to feel badly if they say the wrong thing, they will be reluctant to communicate. Instead, show your students that good thinking grows out of clarifying muddled thinking. It is reasonable for students to have some errors in their thinking and it is your job to help shape that thinking. If a student answers incorrectly, it is your job to ask follow-up questions that will help the student clarify his or her own thinking. For example, suppose a problem requires a student to describe the common factors of two numbers. The student hesitates or answers inappropriately. Follow up by asking questions like the following:

*It is through communication that students clarify their own thinking as well as show you and their classmates what they do or do not understand.*

*Students will be reluctant to communicate unless the environment is risk-free.*

- *What is a factor?*
- *Are the factors of 30 more or less than 30?*
- *Is 2 a factor of both numbers?*
- *Why could you call it a common factor?*

- Many of the questions in the textbook require students to explain their thinking. The sample *Thinking* in the *Examples* is designed to provide a model for mathematical communication.
- One of the ways students communicate mathematically is by describing how they know an answer is right. Even when a question does not ask students to check their work, you should encourage them to think about whether their answer makes sense. When they check their work, they should usually check using a different way than the way they used to find their answer so that they do not make the same reasoning error twice. This will enhance their mathematical flexibility.

*The sample Thinking in the Examples is designed to provide a model for mathematical communication.*

## MATHEMATICAL TOOLS

### Manipulatives

There is great value in using manipulative materials in mathematics instruction. Sometimes, it is essential. For example, Chapter 3 in Unit 2 cannot be completed without using interlocking or connecting cubes. Other times, for example, in Unit 1, some students will be successful without manipulative materials, but all students will benefit from using pattern block shapes. Students will start to see not only how to perform arithmetic calculations, but why they are done the way they are.

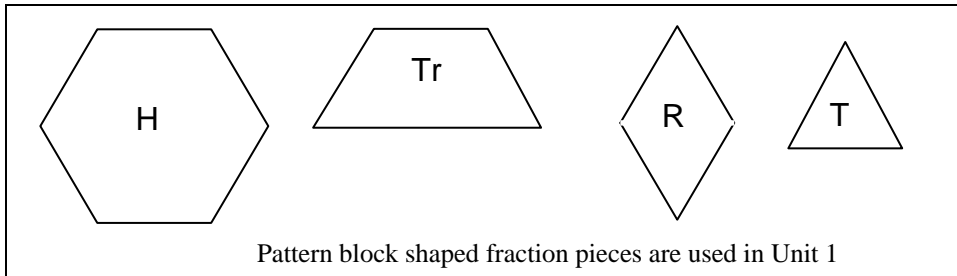

## THE STUDENT NOTEBOOK

It is valuable for students to have a well-organized, neat notebook to look back at to review the main mathematical ideas they have learned. However, it is also important for students to feel comfortable doing rough work in that notebook or doing rough work elsewhere without having to waste time copying it neatly into their notebooks. In addition to the things you tell students to include in their notebooks, they should be allowed to make some of their own decisions about what to include in their notebooks.



*Students should be allowed to make some of their own decisions about what to include in their notebooks.*

## STRAND A: NUMBER

**KSO Number** *By the end of Class 6 students should*

- ◆ *have strong number sense with respect to whole numbers and decimals, and be able to draw on a wide variety of relationships and strategies to solve problems in new situations*
- ◆ *have a strong sense of the base ten system to millions and thousandths, and use place value patterns to understand new ideas and apply reasoning to computational problems and mental mathematics within mathematics itself and in real world situations*
- ◆ *efficiently select and apply appropriate estimation strategies, to answer real life questions and check for reasonableness of answers in calculation*
- ◆ *understand fractions and decimals to thousandths, and the relationship between them, and move freely from one form of representation to another, as might be appropriate in a given situation, to provide a strong foundation for higher level fractional ideas and computation*
- ◆ *understand meanings and appropriate application of integers, ratios, and percent in real world situations*
- ◆ *apply number theory concepts in relevant situations as a way to solve problems*

Toward this, students in **Class 6** will be expected to master the following **SO** (Specific Outcomes):

### **6-A1 Renaming: mixed numbers and improper fractions**

- move between improper and mixed number formats

### **6-A2 Comparing Fractions: develop procedures**

- compare fractions using benchmarks
- compare fractions using a common denominator
- compare fractions using a common numerator
- compare using equivalent decimals

### **6-A3 Renaming: simple fractions and decimals**

- use models to make the connection between fractions and division
- investigate repeating decimals through concrete models (no symbolism)

### **6-A4 Ratio: part to part, part to whole**

- represent ratios with concrete models
- understand that ratios are comparisons
- compare a part to a whole (e.g., in a group of 6 boys and 4 girls, the ratio 6 : 10 describes the ratio of boys to the whole group)
- compare a part to a part (e.g., in a group of 6 boys and 4 girls, the ratio 6 : 4 describes the ratio of boys to girls)

### **6-A5 Equivalent Ratios: using models and symbols**

- connect models and symbols to develop multiplicative relationships (e.g., 3 : 5, 6 : 10, 12 : 20, ...)
- simplify ratios to make interpretation of situations easier (e.g., 36 : 9 = 4 : 1)

### **6-A6 Similarity: name, describe, and represent**

- understand when shapes are similar (corresponding angles are equal and pairs of corresponding sides are equal multiples of each other)

**6-A7 Rates: relating to ratio**

- recognize that rates are just like ratios except that they are comparisons of items in different units.
- recognize that a rate can be described in more than one way
- compare rates

**6-A8 Percent: developing benchmarks and number sense**

- understand that percent is a special part-to-whole ratio, where the second term is 100
- represent percentages pictorially
- recognize everyday situations in which percent is used
- use percents as equivalent ratios to make comparisons easier
- relate percent and decimal names of ratios (e.g.,  $37\% = 0.37 = 37$  hundredths)
- find percent equivalents for benchmark fractions/ratios such as  $\frac{1}{4}$ ,  $\frac{1}{2}$ , and  $\frac{3}{4}$

**6-A9 Large Numbers: reading and writing**

- read and write large numbers in words (e.g., three hundred forty-five million)
- write large numbers in terms of different units (e.g., 13,200,000 as 13,200 thousand or 13.2 million)
- write the expanded form of a number (e.g., 3402 as  $3 \times 1000 + 4 \times 100 + 2$ )

**6-A10 Place Value: understanding place value patterns**

- understand that the place value system follows a pattern: each place has a value that is 10 times as much as the place to its right and each place has a value that is  $\frac{1}{10}$  as much as the place to its left
- understand that digits are grouped in 3s for the purpose of interpreting and reading numbers

**6-A11 Integers: negative and positive**

- develop meaning of integers using models and symbols
- explore negative integers in context (e.g., temperature, money, sea level heights)
- understand that each negative integer is the opposite of a positive integer with respect to 0 on a number line
- understand that 0 is neither positive or negative
- compare integers

**6-A12 Prime Numbers: distinguish from composites**

- understand that a prime number is a number that has exactly two factors
- model prime numbers as dimensions (other than 1) of unique rectangles with particular whole number areas
- understand that 1 is not a prime number

**6-A13 Factors: whole numbers**

- conclude that a number is a multiple of any of its factors
- find factors by dividing systematically
- understand, through investigation, that the greatest factor is always the number itself and the least factor is always 1
- understand, through investigation, that the second greatest factor is always  $\frac{1}{2}$  the number or less

**6-A14 Common Factors: whole numbers**

- find factors in a systematic way
- understand that 1 is always a common factor of any two numbers
- find common factors of two or three numbers

## STRAND B: OPERATIONS

**KSO Operations** *By the end of Class 6 students should*

- ♦ *model and solve computational problems involving whole numbers and decimals by selecting appropriate operations and procedures for computation, estimation, and mental math*
- ♦ *choose an appropriate method of computation in given situations (including pencil/paper, mental math, estimation)*
- ♦ *model and solve problems involving the addition and subtraction of simple fractions and be able to justify answers through reasoning*
- ♦ *informally explore simple algebraic situations*
- ♦ *demonstrate flexibility in procedures chosen to solve computational problems*

Toward this, students in **Class 6** will be expected to master the following **SO** (Specific Outcomes):

### **6-B1 Addition and Subtraction: simple fractions with various denominators**

- develop conceptual understanding of fraction addition and subtraction by exploring models (pattern blocks, fraction circles)
- solve fractions problems in context

### **6-B2 Estimation Strategies for Multiplication and Division: whole numbers and decimals**

- apply estimation strategies: rounding, front-end

### **6-B3 Multiply Decimals by Whole Numbers: pictorially, symbolically**

- compute products of whole numbers using an algorithm
- know when to use a pencil/paper algorithm or a mental procedure
- regularly estimate when performing computations

### **6-B4 Multiply Decimals by Decimals: concretely and symbolically**

- use meaningful strategies to calculate products of decimals
- regularly estimate when performing computations

### **6-B5 Whole Numbers and Decimals: single-digit division**

- relate to whole number division
- link concrete models to algorithms
- regularly estimate when performing computations

### **6-B6 Divide Mentally: whole numbers by 0.1, 0.01, 0.001**

- recognize the pattern of changes produced by dividing by 0.1, 0.01, 0.001 is the same as that produced by multiplying by 10, 100, 1000
- describe these patterns in terms of place value changes

### **6-B7 Divide Decimals by Decimals: estimating and developing algorithms through reasoning**

- use meaningful strategies to calculate quotients of decimals

### **6-B8 Addition and Subtraction of Decimals and Whole numbers: choosing most appropriate method**

- choose among written, mental calculations, estimation as the most appropriate method
- regularly estimate when performing computations
- apply strategies: front-end estimation, compensation (e.g.,  $14.95 + 1.99 + 10.98 - 7.1 = 15 + 2 + 11 - 8 = 20$ )

## STRAND C: PATTERNS AND RELATIONSHIPS

**KSO Patterns and Relationships** *By the end of Class 6 students should*

- ◆ *describe, extend, and create patterns to solve problems in real world situations and mathematical contexts (in number, geometry, and measurement)*
- ◆ *use patterns to generalize mathematical situations to aid in solving problems and understanding relationships*
- ◆ *explore and generalize how a change in one quantity in a relationship affects another, in order to efficiently solve similar but new problems*
- ◆ *represent mathematical patterns and relationships in a variety of ways (charts, tables, graphs, and numerically)*
- ◆ *use patterns to assist in mental math strategies*
- ◆ *informally solve linear equations via open sentences using reasoning*

Toward this, students in **Class 6** will be expected to master the following **SO** (Specific Outcomes):

### **6-C1 Linear Equations: using open frames**

- solve simple linear open frame equations in context (e.g., 23 students, 8 are absent, others are sitting in groups of 3. How many groups?  $3 \times \square + 8 = 23$ )
- replace open frames with letters

### **6-C2 Literals to Represent Variables: represent situations describing literal variables**

- use letters to represent variable quantities
- understand irrelevance of the choice of letter to represent a variable

### **6-C3 Volume Patterns: explore**

- explore how a change in one dimension of affects the volume of a rectangular prism and relate this to the volume formula,  $V = l \times w \times h$

### **6-C4 Area Patterns: explore**

- represent symbolically changes in area based on changes in linear dimensions (e.g., parallelograms:  $A = bh$  so if  $b$  and  $h$  are both doubled, area is quadrupled; if  $b$  is doubled but  $h$  is halved the area remains the same)

### **6-C5 Equivalent Ratios: change in one term affects the other term**

- explore symbolically how a change in one term of a ratio affects the other

### **6-C6 Square and Triangular Numbers: represent pictorially and symbolically**

- represent square and triangular numbers pictorially and symbolically to show both geometric and numerical patterns
- understand that square numbers may be represented in square arrays and are the products of numbers multiplied by themselves
- understand that a triangular number is half the number in an array with dimensions that are one unit apart



## STRAND D: MEASUREMENT

**KSO Measurement** *By the end of Class 6 students should*

- ◆ *understand relationships among common SI units and choose appropriate units to solve measurement problems in given situations*
- ◆ *move freely among common SI units to communicate measurement ideas effectively, appropriate to a given measurement situation*
- ◆ *estimate effectively using a variety of strategies to solve measurement problems and understand when estimation is appropriate*
- ◆ *use relationships and reasoning to develop and apply procedures for measuring in real situations and mathematical contexts*

Toward this, students in **Class 6** will be expected to master the following **SO** (Specific Outcomes):

### **6-D1 Area: calculate to solve problems**

- calculate area in  $\text{cm}^2$ ,  $\text{m}^2$ ,  $\text{km}^2$
- choose appropriate units for situations

### **6-D2 Parallelograms: relate bases, heights, and areas**

- understand that the area of a parallelogram is the same as the area of a rectangle with the same base and height
- determine the base or height, given the area and the other dimension
- understand that a variety of parallelograms can have the same area

### **6-D3 Area of a Triangle: relate to area of a parallelogram**

- understand that any triangle is one half of a parallelogram
- understand that the area of a triangle is half the area of the parallelogram with the same base and height
- understand that the areas of different triangles are equal if their bases and heights are equal

### **6-D4 SI Units: Relationships**

- investigate the relationship between linear SI units and the relationship between corresponding SI area and volume units

### **6-D5 Volume and Capacity: relationships**

- understand that capacity and volume are both measures of the size of a 3-D shape
- understand that volume is a measure of how much space is occupied by a 3-D shape
- understand that capacity is a measure of how much a 3-D shape can hold
- explore the relationship between the cubic units of volume and capacity ( $1 \text{ cm}^3 = 1 \text{ mL}$ ,  $1 \text{ dm}^3 = 1 \text{ L}$ ,  $1 \text{ m}^3 = 1 \text{ kL}$ )

### **6-D6 Time: solve problems**

- solve problems involving time
- read and record time using the 24-hour clock
- change time in 24-hour time to 12-hour time and vice versa

### **6-D7 Mass: tonnes**

- understand that the tonne is a measure of mass and is equivalent to 1000 kg
- solve problems involving tonnes

### **6-D8 Angles: estimate, measure, and draw**

- use a protractor as a tool for measuring angles
- estimate, measure, and draw angles from  $0^\circ$  to  $180^\circ$

## STRAND E: GEOMETRY

**KSO Geometry** *By the end of Class 6 students should*

- ♦ *identify, draw, compare, and build physical models of 2-D and 3-D shapes to focus on their attributes and understand how they affect everyday life*
- ♦ *predict and verify results of transforming, combining, and subdividing shapes to understand other shapes and explain other geometrical ideas*
- ♦ *use geometric relationships and spatial reasoning to solve problems and understand everyday events and objects, as well as higher geometrical ideas*
- ♦ *appreciate the importance of geometry in understanding mathematical ideas and the world around us*

Toward this, students in **Class 6** will be expected to master the following **SO** (Specific Outcomes):

**6-E1 Rotations:**  $\frac{1}{4}$  (**90°**),  $\frac{1}{2}$  (**180°**), and  $\frac{3}{4}$  **turns**

- use a variety of turn centres: a vertex, on a side, and inside and outside the shape

**6-E2 Rotational Symmetry Properties: squares and rectangles**

- recognize, through concrete investigation, when a shape has rotational symmetry
- discover, through concrete investigation, that a square has rotational symmetry of order 4 while a non-square rectangle has rotational symmetry of order 2
- relate rotational symmetry of squares and rectangles to other properties of squares and rectangles

**6-E3 Rotational Symmetry: properties**

- generalize for quadrilaterals and regular polygons
- understand that, for a 2-D shape to have rotational symmetry, it must be turned around a point so that it exactly coincides with its original position at least once in less than a complete rotation
- understand that the number of times it appears in the identical original position during one complete rotation is the order of turn symmetry
- understand that if a shape has turn symmetry of order 1 (i.e., it needs to be rotated 360° before it appears in the identical original position), then it does not have rotational symmetry

**6-E4 Combining Transformations: predict and confirm results**

- predict and confirm the results of two transformations
- understand that two congruent shapes on the same plane are images of one another under a translation, reflection, rotation, or any combination of these three transformations

**6-E5 Tessellations**

- understand that, to tessellate, a shape must cover a surface with replications and without gaps or overlaps
- describe, predict, and investigate a variety of shapes for tessellating properties

**6-E6 Bisectors: angles and line segments**

- recognize and describe angle bisectors
- recognize and describe line segment bisectors, including perpendicular bisectors

**6-E7 Quadrilaterals: sort by attributes**

- sort concretely by angles

**6-E8 Diagonal Properties: generalize**

- generalize about diagonals for a rhombus: the diagonals are perpendicular to each other and bisect each other, form four congruent right triangles, and are its two lines of reflective symmetry
- generalize about diagonals for a parallelogram: the diagonals bisect each other and form two pairs of congruent triangles
- generalize about diagonals for a kite: the diagonals are perpendicular and form two pairs of congruent right triangles; one of the diagonals is bisected, and the other diagonal is a line of reflective symmetry
- understand that there are no special properties of the diagonals of a general trapezoid

**6-E9 Planes of Symmetry: 3-D shapes**

- understand that some 3-D shapes have planes of reflective symmetry
- investigate cubes, cones, cylinders, prisms, and pyramids for planes of symmetry

**6-E10 Cross Sections: cones, cylinders, prisms, and pyramids**

- understand that a cross-section is the 2-D face produced when a straight cut is made through a 3-D shape
- examine the properties of cross-sections concretely (e.g., cone: if a cut is made parallel to its base, the cross-section face produced is a circle; if a cut is made through its vertex and perpendicular to its base, the cross-section face is a triangle)

**6-E11 Orthographic Drawings: make and interpret**

- make and interpret structures built from cubes
- understand that orthographic drawings are a set of 2-D views of a 3-D structure drawn by looking at it directly from the front, sides, top, and back

**STRAND F: DATA MANAGEMENT**

**KSO Data Management** *By the end of Class 6 students should*

- ◆ *collect, record, organize, and describe data in multiple ways to draw conclusions about everyday issues*
- ◆ *construct a variety of data displays and choose the most appropriate*
- ◆ *predict, read, interpret, and modify predictions for a variety of data displays, including interpolation and extrapolation (i.e., draw conclusions about things not specifically represented by the data)*
- ◆ *develop and apply measures of central tendency to data reflecting relevant situations, in order to draw conclusions and make decisions*
- ◆ *design and implement strategies for the collection of data*

Toward this, students in **Class 6** will be expected to master the following **SO** (Specific Outcomes):

**6-F1 Evaluate Data: choose appropriate samples**

- consider the issue of sampling (sources of bias and sample size)

**6-F2 Bar and Double Bar Graphs: construct and interpret**

- construct and interpret bar graphs and double bar graphs with intervals

**6-F3 Stem and Leaf Plots: grouping and displaying data**

- construct stem and leaf plots to display grouped numerical data (e.g., heights of students in a class)

11 | 0 7 6  
 12 | 1 4 4 3  
 13 | 2 4

**6-F4 Line Graphs: construct and interpret**

- understand that the purpose of a line graph is to focus on trends implicit in the data (e.g., for temperature change over time)

**6-F5 Coordinates: plotting**

- plot data in all four quadrants
- understand that a negative number for the second coordinate indicates that the point is below the horizontal axis
- understand that a negative number for the first coordinate indicates that the point is left of the vertical axis
- understand that the point at which the axes intersect has coordinates (0, 0) and is known as the origin

**6-F6 Mean, Median, and Mode: concepts**

- understand conceptually
  - the mean is the average calculated by taking a total amount of the pieces of data and sharing it equally among the pieces of data
  - the median is another type of average; it is the middle number in an ordered set of data
- understand that the mean and median may be the same or may be different
- understand that the mode is a type of average; it shows the data that appear most often

## STRAND G: PROBABILITY

**KSO Probability** *By the end of Class 6 students should*

- ◆ *explore, interpret, and make predictions for everyday events by estimating and conducting experiments*
- ◆ *understand the difference between theoretical and experimental probability and when each is relevant*
- ◆ *conduct simulations to model and understand real-life probability situations*
- ◆ *understand the relationship between the numerical representations of probability and the events they represent*

Toward this, students in **Class 6** will be expected to master the following **SO** (Specific Outcomes):

**6-G1 Reliability: evaluate**

- evaluate sampling results
- understand that data from larger samples generally produce more reliable probabilities

**6-G2 Theoretical Probability: determine**

- understand that theoretical probability is the number of favourable outcomes divided by the number of possible outcomes
- use fractions, decimals, and percents to describe probabilities
- identify events that might be associated with a particular theoretical probability

# UNIT 1 FRACTIONS AND DECIMALS

## UNIT 1 PLANNING CHART

	Outcomes or Purpose	Suggested Pacing	Materials	Suggested Assessment
Getting Started SB p. 1 TG p. 4	Review prerequisite concepts, skills, and terminology and pre-assessment	1 h	None	All questions
<b>Chapter 1 Relating Fractions</b>				
1.1.1 Relating Mixed Numbers to Improper Fractions SB p. 3 TG p. 7	<b>6-A1 Renaming: mixed numbers and improper fractions</b> • move between improper and mixed number formats	1 h	• 3 paper squares for each student or pair • Scissors	Q1, 2, 4, 5
1.1.2 Comparing and Ordering Fractions SB p. 6 TG p. 10	<b>6-A2 Comparing Fractions: develop procedures</b> • compare fractions using benchmarks • compare fractions using a common denominator • compare fractions using a common numerator • compare using equivalent decimals	1 h	None	Q1, 3, 5
1.1.3 EXPLORE: Adding and Subtracting Fractions (Optional) SB p. 9 TG p. 13	<b>6-B1 Addition and Subtraction: simple fractions with various denominators</b> • develop conceptual understanding of fraction addition and subtraction by exploring models (pattern blocks, fraction circles) • solve fractions problems in context	40 min	• Pattern blocks, or Pattern Block Fraction Pieces (BLM)	Observe and Assess questions
1.1.4 Adding Fractions SB p. 10 TG p. 15	<b>6-B1 Addition and Subtraction: simple fractions with various denominators</b> • develop conceptual understanding of fraction addition and subtraction by exploring models (pattern blocks, fraction circles) • solve fraction problems in context	1 h	• Fraction Strips (BLM) • Scissors • Grid paper or Small Grid Paper (BLM) (optional)	Q2, 3, 8
CONNECTIONS: Fractions between Fractions (Optional) SB p. 14 TG p. 18	<b>6-A2 Comparing Fractions: develop procedures</b> • compare fractions using benchmarks	30 min	• Fraction Strips (BLM)	N/A
1.1.5 Subtracting Fractions SB p. 15 TG p. 19	<b>6-B1 Addition and Subtraction: simple fractions with various denominators</b> • develop conceptual understanding of fraction addition and subtraction by exploring models (pattern blocks, fraction circles) • solve fraction problems in context	1 h	• Fraction Strips (BLM) • Grid paper or Small Grid Paper (BLM) (optional)	Q2, 4, 5

## UNIT 1 PLANNING CHART [Continued]

	Outcomes or Purpose	Suggested Pacing	Materials	Suggested Assessment
<b>Chapter 2 Relating Fractions to Decimals</b>				
<b>1.2.1</b> Naming Decimals as Fractions <b>SB p. 19</b> <b>TG p. 22</b>	<b>6-A3 Renaming: simple fractions and decimals</b> • use models to make the connection between fractions and division <b>6-A2 Comparing Fractions: develop procedures</b> • compare fractions using equivalent decimals	1 h	• Hundredths Grids (BLM)	Q1, 4, 6
GAME: Fraction Match <b>SB p. 21</b> <b>TG p. 24</b>	Practise renaming fractions and decimals in a game situation	20 min	• Fraction Match Game Cards (BLM)	N/A
<b>1.2.2</b> Naming Fractions as Decimals <b>SB p. 22</b> <b>TG p. 25</b>	<b>6-A3 Renaming: simple fractions and decimals</b> • use models to make the connection between fractions and division • investigate repeating decimals through concrete models (no symbolism)	1 h	• Hundredths Grids (BLM)	Q1, 3, 4
UNIT 1 Revision <b>SB p. 25</b> <b>TG p. 27</b>	Review the concepts and skills in the unit	2 h	• Fraction Strips (BLM) • Hundredths Grids (BLM)	All questions
UNIT 1 Test <b>TG p. 29</b>	Assess the concepts and skills in the unit	1 h	• Fraction Strips (BLM) • Hundredths Grids (BLM)	All questions
UNIT 1 Performance Task <b>TG p. 31</b>	Assess concepts and skills in the unit	1 h	• Fraction Strips (BLM)	Rubric provided
UNIT 1 Blackline Masters <b>TG p. 34</b>	BLM 1 Fraction Match Game Cards BLM 2 Fraction Strips (1 Whole to Twelfths) BLM 3 Pattern Block Fraction Pieces (for <b>lesson 1.1.3</b> ) BLM 4 Hundredths Grids BLM 5 Small Grid Paper			

## Math Background

- Work with fractions and decimals is fundamental to success in mathematics beyond Class VI. This number unit supports students' development in this area.
- The focus of the unit is on relating fractions and mixed numbers to each other. Students will learn to compare fractions and to rename them either as other fractions or as decimals. They will use concrete materials to explore adding and subtracting fractions.
- As students proceed through this unit they will use a variety of mathematical processes, including problem solving, communication, reasoning, representation, visualization, and making connections.

For example:

- Students use problem solving in **question 4** in **lesson 1.1.4**, where they find pairs of fractions with a particular sum, and in **question 4** in **lesson 1.1.5**, where they find pairs of fractions with a particular difference.
- Students use communication in **question 7** in **lesson 1.1.2**, where they discuss situations that make fractions easier to compare, in **question 6** in **lesson 1.1.5**, where they think about when they can and cannot compare two fractions, and in **question 3** in **lesson 1.2.2**, where they explain how knowing one piece of information gives them insight into other information.
- Students use reasoning in answering questions such as **question 6** in **lesson 1.1.1**, where students consider what numerator is possible for a mixed number, in **question 6** in **lesson 1.1.2**, where they calculate missing values for open number sentences, and in **question 5** in **lesson 1.1.4**, where they decide how a statement might be true
- Students consider representation in **lesson 1.1.3**, where they represent fraction sums and differences by relating to pattern blocks, in **question 3** in **lesson 1.1.5**, where they write a subtraction sentence to fit a model, and in **lesson 1.2.1**, where they realize that a decimal hundredth can be represented in several ways.

- Students use visualization skills in **question 2** in **lesson 1.1.2**, where they use a diagram to compare two fractions, in **question 2** in **lesson 1.1.4**, where they use fraction strips to add fractions, and in **question 3** in **lesson 1.2.1**, where they use pictures of hundredths grids to compare decimals.
- Students make connections in situations like those in **question 3** in **lesson 1.1.1**, where they link mixed numbers to improper fractions, in **question 4** in **lesson 1.1.2**, where they relate comparisons of fractions to real-world situations, and in **question 7** in **lesson 1.2.1**, where they relate decimals to fractions.

## Rationale for Teaching Approach

- This unit is divided into two chapters.  
**Chapter 1** focuses on fractions.  
**Chapter 2** focuses on relating fractions and decimals.
- The **Explore** lesson allows students to develop their own ideas about how fractions should be added or subtracted before they are taught strategies.
- The **Connections** section models for students how to explore a conjecture (hypothesis) about how fractions can be compared.
- The **Game** provides an opportunity for students to practice renaming fractions as decimals and as other fractions.
- Throughout the unit, the focus is on developing meaning and not on just learning rules. It is important for students to recognize the value in doing this.

## Getting Started

Curriculum Outcomes	Outcome relevance
4 Mixed Numbers: modelling 4 Hundredths: model and record 5 Meaning of Fractions: division 5 Rename Fractions: with and without models (conceptual) 5 Compare and Order fractions (using reasoning)	Students will find the work in the unit easier after they review their work on fractions and decimals from Classes IV and V.

Pacing	Materials	Prerequisites
1 h	None	<ul style="list-style-type: none"> <li>interpreting and representing fractions and mixed numbers</li> <li>deciding whether two fractions are equivalent</li> <li>comparing fractions</li> <li>using decimal hundredths to describe a model</li> </ul>

### Main Points to be Raised

#### Use What You Know

- A fraction can represent a part of a set, a part of a whole (region), or a position on a number line.
- The denominator of a fraction tells into how many equal parts the whole is divided. The numerator tells how many parts are being used.
- There are many representations for the same fraction.

#### Skills You Will Need

- Fractions are equivalent if they represent the same part of a whole.
- One fraction is less than another fraction if it occupies less of a whole.
- A mixed number includes a whole number part which is added to a fraction part.
- The decimal  $0.ab$  represents  $ab$  parts of 100.

### Use What You Know — Introducing the Unit

- Before assigning the activity, draw a square on the board. Divide it into three equal sections and mark two of the sections. Ask students what fraction you have marked. Ask how they know.

- Ask students to tell you as much as they can about the fraction  $\frac{2}{3}$ .

For example, they might say that the denominator is 3 (you could ask what the 3 means) or that the numerator is 2 (you could ask what the 2 means). They might compare it to  $\frac{1}{3}$  or perhaps to  $\frac{1}{2}$ .

- If students have not yet suggested that  $\frac{2}{3}$  could represent 2 out of 3 objects, erase the square and draw three identical, but separate, squares. Ask students how you could mark  $\frac{2}{3}$  of the group of squares.
- Students can then work in pairs to complete the activity.

While you observe students at work, you might ask questions such as the following:

- What does the 1 tell you?* (Only one boy is younger than 4 years old.)
- I notice all of your pictures are circles. How could you show  $\frac{1}{4}$  of a rectangle?* (I could cut out a rectangle and fold it in half twice.)



- How did you know that the  $\frac{1}{4}$  went there? (I imagined splitting the line in half and then I divided the first half of the line in half again.)
- Why did you choose  $\frac{17}{41}$  to describe our class? (It tells what fraction of the class are boys because there are 17 boys and 41 students.)

### Skills You Will Need

- To ensure students have the required skills for this unit, assign these questions.
- You may wish to check that students recall what decimals are by asking what 0.02 mean and what 0.3 means before the students begin work.
- Students can work individually.

### Answers

NOTE: Read about **Answers** on **page xiv** in the **Introduction** to this **Teacher's Guide**.

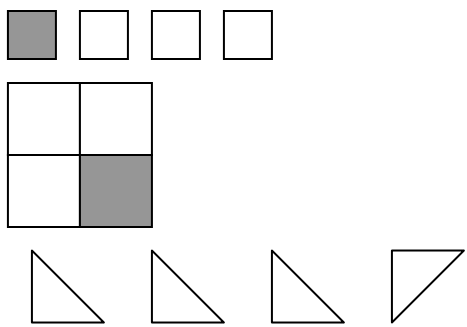
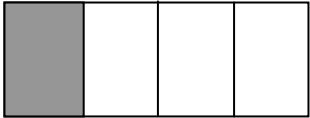
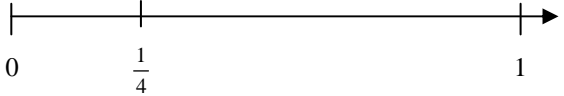
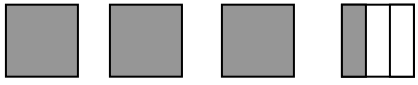
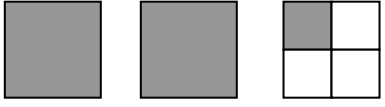
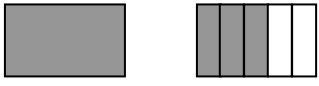
<p><b>A.</b> <math>\frac{1}{4}</math></p> <p><b>B. Sample response:</b></p> 	<p><b>C.</b></p>  <p><i>Sample response:</i> I divided the rectangle in half and then I divided each half in half.</p> <p><b>D.</b></p>  <p><b>E. Sample response:</b></p> <ul style="list-style-type: none"> <li>• We are working in groups of 4 and 1 of the 4 people in my group is a girl.</li> <li>• There are 4 windows, but only 1 of them is open all the way.</li> </ul>
<p><b>1.</b> A and B</p> <p><b>2. a) i)</b> <math>\frac{3}{4}</math>                      <b>ii)</b> <math>\frac{1}{3}</math></p> <p><b>iii)</b> <math>\frac{1}{6}</math>                              <b>iv)</b> <math>\frac{2}{4}</math></p> <p><b>b)</b> <math>\frac{1}{6}, \frac{1}{3}, \frac{2}{4}, \frac{3}{4}</math></p>	<p><b>3. Sample responses:</b></p> <p><b>a)</b></p>  <p><b>b)</b></p>  <p><b>c)</b></p>  <p><b>4. a)</b> 0.3 or 0.30                      <b>b)</b> 0.19</p>

## Supporting Students

### *Struggling students*

- Some students who are comfortable identifying fractions may have difficulty representing them, particularly as parts of groups or as points on a number line. You may need to do some review work with these students, emphasizing how they can begin with one representation to get other representations.

For example, show them how to start with a part of a whole representation. You might show  $\frac{3}{5}$  by joining together 5 identical squares and colouring 3 of them. They can then separate the squares to show  $\frac{3}{5}$  of a group. Then they can push the squares together again and place them against a number line to represent  $\frac{3}{5}$  as a point on the number line.

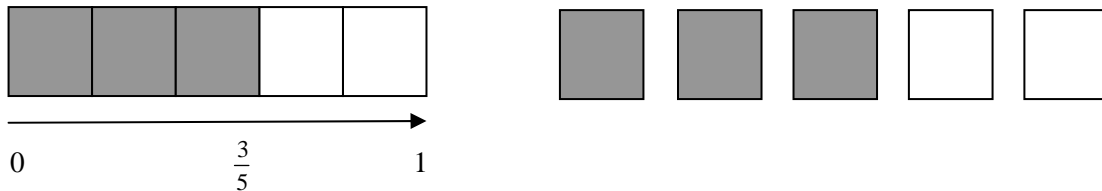

- Some students might think that fractions like  $\frac{3}{5}$  and  $\frac{3}{8}$  are equivalent because the numerators are the same. Make sure they understand that equivalent means that the same area of a whole would be shaded, not just that there are the same number of parts.

### *Enrichment*

- Encourage students to draw more unusual shapes to answer **part B** of **Use What You Know**.

For example, they could use shapes like these:

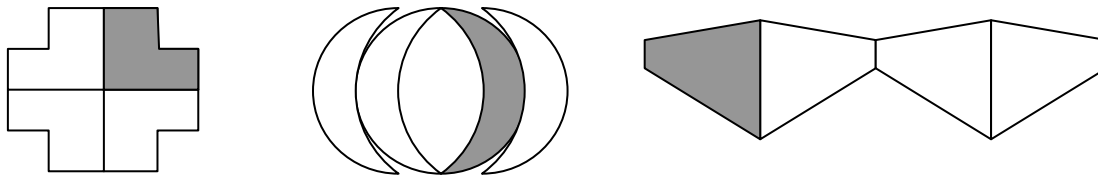

# Chapter 1 Relating Fractions

## 1.1.1 Relating Mixed Numbers to Improper Fractions

Curriculum Outcomes		Outcome relevance
<b>6-A1 Renaming: mixed numbers and improper fractions</b> <ul style="list-style-type: none"><li>• move between improper and mixed number formats</li></ul>		Although students normally have a better sense of the size of a fraction greater than 1 if it is written as a mixed number, it is important to be able to rename a mixed number as an improper fraction for certain fraction calculations in higher classes.
Pacing	Materials	Prerequisites
1 h	<ul style="list-style-type: none"><li>• 3 paper squares for each student or pair</li><li>• Scissors</li></ul>	<ul style="list-style-type: none"><li>• representing fractions as parts of a whole</li><li>• identifying fractions as parts of a whole</li><li>• understanding that 1 can be written as a fraction of the form <math>\frac{a}{a}</math></li></ul>

### Main Points to be Raised

- The denominator of a fraction tells how many equal parts make a whole. The numerator tells how many parts of the whole the fraction is describing.
- If the numerator of a fraction is greater than or equal to the denominator, it is called an improper fraction.
- A mixed number is made up of a whole number part and a fraction part. The mixed number is the sum of the two parts.
- To write an improper fraction as a mixed number, you can divide the numerator by the denominator. The quotient is the number of wholes. The remainder tells you the fraction part.
- To write a mixed number as an improper fraction, rewrite each whole number as a fraction of the form  $\frac{a}{a}$ , where  $a$  is the denominator of the fraction part of the mixed number and the parts are combined.

### Try This — Introducing the Lesson

A. Allow students to try this alone or with a partner. While you observe students at work, you might ask questions such as the following:

- *How did you divide your square into fourths?* (I folded it in half one way and then in half the other way.)
- *How many fourths are there altogether?* (twelve fourths)
- *Why is your design that uses 9 fourths called  $\frac{9}{4}$  no matter what it looks like?* (There are many ways to show any fraction. For example,  $\frac{1}{4}$  can be part of a circle or part of a square.)

### The Exposition — Presenting the Main Ideas

- On the board, draw three circles, each divided into sixths. Fully shade the first two circles and shade two sections of the third circle.

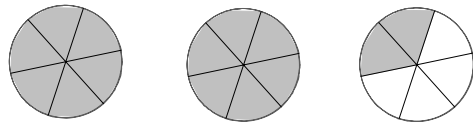

Ask students how many sixths of each circle are shaded. Write each fraction and point out the denominator and numerator in each case.

Ask why you might write  $2\frac{2}{6}$  to describe the whole amount. Ask why you could also write  $\frac{14}{6}$ .

Point out that the two expressions are equal and how it makes sense that 14 sixths = (6 + 6 + 2) sixths.

Help students see that to get from  $2\frac{2}{6}$  to  $\frac{14}{6}$ , you rewrite each whole as 6 sixths ( $\frac{6}{6}$ ). [Continued]

Point out that if you start with  $\frac{14}{6}$ , you work backwards. You need 6 sixths to make each whole, so you have to find out how many 6s are in 14. Since  $14 \div 6 = 2 \text{ R } 2$ , the mixed number is  $2\frac{2}{6}$ . There are 2 wholes because there are 2 groups of 6 in 14. There are  $\frac{2}{6}$  because there is a remainder of 2 objects that are sixths.

- Have students look at the models in the exposition on page 3 to see why  $\frac{7}{3} = 2\frac{1}{3}$ .

### Revisiting the Try This

**B.** Some students may realize that expressions like *ab fourths* suggest an improper fraction form. They should also realize that the whole number part of the mixed number tells how many squares of the original size they could have made.

### Using the Examples

- Write the questions in **examples 1 and 2** on the board. Ask students to try them and then compare their solution and their thinking to what is in the student text. Point out that they are expected to write down their work, much like what they see on the left (under **Solution**), while they might be thinking what they read on the right (under **Thinking**).
- Work through **example 3** with the students. Make sure they understand why the student in the example used division.

### Practising and Applying

#### Teaching points and tips

**Q 1:** Encourage students to draw sketches to support their work.

**Q 2:** If students draw pictures, ask them why they would split the 3 wholes into halves, the 4 wholes into fourths and the 6 wholes into fifths to figure out the improper fractions.

**Q 3 a):** This question involves reasoning. Students need to realize that they can multiply the denominator by 5 and by 6 and use numerators between those two values.

For example,  $\frac{?}{5} \rightarrow 5 \times 5 = 25$  and  $5 \times 6 = 30$ , so  $\frac{?}{5}$  could be  $\frac{26}{5}$  ( $5\frac{1}{5}$ ),  $\frac{27}{5}$  ( $5\frac{2}{5}$ ),  $\frac{28}{5}$  ( $5\frac{3}{5}$ ), or  $\frac{29}{5}$  ( $5\frac{4}{5}$ ).

**Q 4:** Observe whether students change the mixed numbers to improper fractions or the improper fractions to mixed numbers. Either way is correct.

**Q 5:** Ask students how they know that the numerator for **part a)** has to be between 24 and 30 and how they know that the fraction part of the mixed numbers for all possible answers to **part b)** is  $\frac{4}{6}$ .

**Q 6:** This question is designed to alert students to the notion that when an improper fraction is written as a mixed number, the fraction part should be less than 1.

**Q 7:** This question might be discussed in small groups.

#### Common errors

- Some students write improper fractions as, for example,  $1\frac{6}{5}$  rather than  $2\frac{1}{5}$ . Make sure students understand that although both are representations for  $\frac{11}{5}$ , we normally use only the second form.

#### Suggested assessment questions from Practising and Applying

<b>Question 1</b>	to see if students can write an improper fraction as a mixed number
<b>Question 2</b>	to see if students can write a mixed number as an improper fraction
<b>Question 4</b>	to see if students can compare fractions and mixed numbers
<b>Question 5</b>	to see if students can solve simple problems involving mixed numbers and improper fractions

## Answers

**A. Sample responses:**

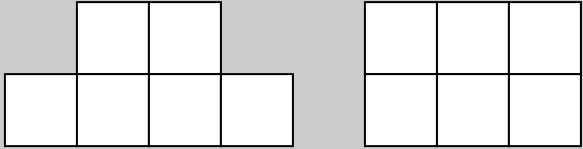
**i)** 

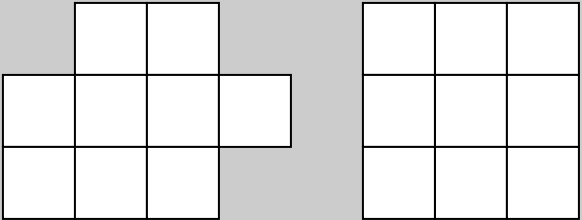
**ii)** 

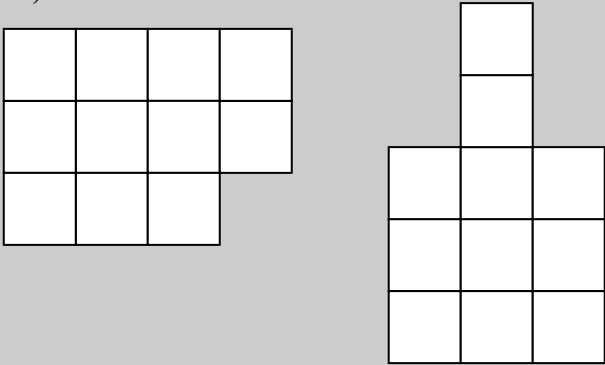
**iii)** 

**B.**  $\frac{6}{4}$  and  $1\frac{2}{4}$ ;  $\frac{9}{4}$  and  $2\frac{1}{4}$ ;  $\frac{11}{4}$  and  $2\frac{3}{4}$ .

*NOTE: Answers or parts of answers to numbered questions that are in square brackets throughout the Teacher's Guide are NOT found in the answers at the back of the student text. (See **Answers** on page **xiv** in the **Introduction** to this Teacher's Guide.)*

**1. a)**  $2\frac{1}{6}$       **b)**  $8\frac{1}{2}$       **c)**  $7\frac{2}{3}$

**2. a)**  $\frac{7}{2}$       **b)**  $\frac{19}{4}$       **c)**  $\frac{32}{5}$

**3. a) i)** 26 to 29  
**ii)** 41 to 47  
**iii)** 51 to 59  
**[b) Sample response:**  
 When I divide the numerator by the denominator, I need a quotient of 5 and a remainder.  
 $\frac{?}{5} \rightarrow ? \div 5 = 5 + R$   
 If the numerator is any number between 26 and 29, it works because  $5 \times 5 = 25$  and  $5 \times 6 = 30$ .]

**4. a)**  $5\frac{3}{4}$ ; [both have a whole number part of 5, but  $\frac{3}{4} > \frac{1}{4}$ .]  
**b)**  $\frac{24}{6}$ ; [ $24 \div 6 = 4$ , which is greater than  $3\frac{2}{3}$ .]

**5. Sample responses:**  
**a)**  $\frac{25}{6}$  and  $\frac{29}{6}$   
**b)**  $3\frac{4}{6}$  and  $5\frac{4}{6}$

**6.** 1 or 2; [*Sample response:*  
 If  $4\frac{?}{3}$  is a mixed number, the fraction part has to be less than 1 and greater than 0.]

**[7. Sample response:**  
 It tells you approximately where the number goes on a number line without counting each part separately.]

## Supporting Students

### Struggling students

- Some students will benefit from continuing to use objects and pictures to show the relationship between improper fractions and mixed numbers rather than moving too quickly to symbolic rules. Using grid paper allows these students to represent any possible numerator and denominator.

For example, to show  $\frac{13}{6}$ , they could draw rectangles made up of 6 squares and count 13 of those squares.

### Enrichment

- You can ask students to create questions like **questions 3 and 6**. Each student can trade questions with a classmate and solve the other's problem.

## 1.1.2 Comparing and Ordering Fractions

Curriculum Outcomes	Outcome relevance
<b>6-A2 Comparing Fractions: develop procedures</b> <ul style="list-style-type: none"><li>• compare fractions using benchmarks</li><li>• compare fractions using a common denominator</li><li>• compare fractions using a common numerator</li><li>• compare using equivalent decimals</li></ul>	Comparing fractions is fundamental to comparing ratios, which is part of real-world consumer math.

Pacing	Materials	Prerequisites
1 h	None	<ul style="list-style-type: none"><li>• representing and identifying fractions</li><li>• finding equivalent fractions</li></ul>

### Main Points to be Raised

- If two fractions have the same denominator, the fraction with the greater numerator is greater.
- If two fractions have the same numerator, the fraction with the greater denominator is less.
- One way to compare two fractions is to compare them both to  $\frac{1}{2}$ . If one fraction is less than  $\frac{1}{2}$  and the other is greater than  $\frac{1}{2}$ , the fraction that is greater than  $\frac{1}{2}$  is the greater fraction.
- Another way to compare two fractions is to rename them to make the comparison easier. You can rename them as decimals if you know the decimal equivalents. You can also rename them as equivalent fractions with the same numerator or as equivalent fractions with the same denominator. Then you can more easily compare the equivalents.

### Try This — Introducing the Lesson

- A. Allow students to try this alone or with a partner. While you observe students at work, you might ask questions such as the following:
- *Did Sonam get more or fewer than half the questions right on each quiz?* (He got more than half right on both quizzes. Half would have been 5 questions on the 10-question quiz, but he got 6 right. Half would have been 15 questions on the 30-question quiz, but he got 20 right.)
  - *If you get more questions right on one quiz than on another, does it mean that you did better on the first quiz?* (No. For example, if I got 5 right out of 5, that is better than getting 8 right out of 20, but  $5 < 8$ .)

### The Exposition — Presenting the Main Ideas

- Ask students which fraction is greater:  $\frac{3}{4}$  or  $\frac{2}{4}$ . Ask them to explain their answers. If they do not suggest it, draw a picture to show how  $\frac{3}{4}$  of one whole is more than  $\frac{2}{4}$  of the same whole. Emphasize that each time there are four pieces, but in one situation more of the pieces are used.
- Then ask whether  $\frac{3}{4}$  or  $\frac{3}{5}$  is greater. Again, ask students to explain why. Emphasize that in both cases they have three pieces but since fourths are bigger than fifths, a group of three larger pieces is more than a group of three smaller pieces.
- Ask students which is greater:  $\frac{1}{10}$  or  $\frac{3}{4}$ , and why. Encourage students to notice that  $\frac{1}{10}$  is not very much of a whole, whereas  $\frac{3}{4}$  is a large part of a whole, and so it is greater.
- Then ask students why someone might write  $\frac{1}{10}$  as  $\frac{2}{20}$  and  $\frac{3}{4}$  as  $\frac{15}{20}$  to compare  $\frac{1}{10}$  to  $\frac{3}{4}$ . Help them see that now they only need to compare 2 and 15 to see which fraction is greater.

- Finally, show how students can rewrite  $\frac{1}{10}$  as 0.1 and  $\frac{3}{4}$  as 0.75 to compare the fractions. They can also rewrite  $\frac{1}{10}$  as  $\frac{3}{30}$  to compare it to  $\frac{3}{4}$ .
- Have students read through the exposition. Answer any questions they might have.

### Revisiting the Try This

**B.** Encourage students to find more than one way to compare the fractions  $\frac{6}{10}$  and  $\frac{20}{30}$ . They can use equivalent fractions with the same denominator (30) or they can use equivalent fractions with the same numerator (60).

### Using the Examples

Present the two questions from the examples for students to try. When they have finished, ask them to read through the thinking and solutions in the student text and compare these to their own work.

### Practising and Applying

#### Teaching points and tips

**Q 1:** Although students could draw pictures of fractions as parts of sets, they will find it much easier to draw fractions as parts of a whole. For example, they can use parts of rectangles or circles. They can show both fractions as part of one picture or use two separate pictures as long as the wholes are the same size.

**Q 2:** Some students will draw another picture showing  $\frac{5}{12}$ . It is important that the whole be the same size as the whole for  $\frac{1}{3}$ . Other students will choose to divide each third into four pieces to make twelfths.

**Q 3:** Encourage students to use different strategies, although you should allow them to use the same strategy if they so choose. Help them see that for **part a)** it makes sense to compare the fractions without changing them because all the numerators are the same. For **part b)** it makes sense to compare the fractions without changing them because all the denominators are the same. More complex strategies might be used for the other parts.

**Q 4:** Some students may choose to write these times in minutes, but it is not necessary to do so.

**Q 5:** You may have to tell students to assume that the two baskets are the same size so they do not worry about that aspect of the problem.

**Q 7:** Some students will point out that this strategy is not always the most useful strategy to use, and that is correct. Others will indicate that it is a strategy that always works.

#### Common errors

- Many students have more difficulty comparing fractions with a common numerator than comparing fractions with a common denominator. They mistakenly assume that the fraction with the greater denominator is greater. Help them see why this is not the case. Encourage them to continue to use this strategy once they get past their misconception because it is a useful strategy.

#### Suggested assessment questions from Practising and Applying

<b>Question 1</b>	to see if students can use a diagram to help them compare fractions
<b>Question 3</b>	to see if students can order a set of fractions
<b>Question 5</b>	to see if students can apply what they know about comparing fractions in a real-world situation

## Answers

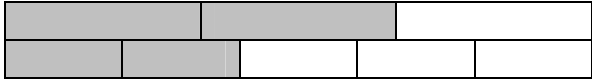
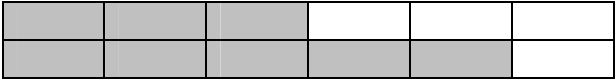
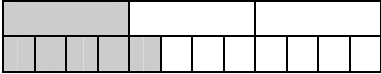
<p><b>A. i)</b> The first quiz</p> <p><b>ii)</b> <i>Sample response:</i> 6 out of 10 is the same as 18 out of 30, which is not as high a mark as 20 out of 30.</p>	<p><b>B. i)</b> <math>\frac{20}{30}</math> and <math>\frac{6}{10}</math></p> <p><b>ii)</b> <i>Sample response:</i> Write <math>\frac{6}{10}</math> as an equivalent fraction with the same denominator, <math>\frac{18}{30}</math>, and then compare the numerators: <math>\frac{18}{30} &lt; \frac{20}{30}</math>, so <math>\frac{6}{10} &lt; \frac{20}{30}</math>.</p>
<p><b>1. Sample responses:</b></p> <p><b>a)</b>  <math>\frac{2}{3} &gt; \frac{2}{5}</math></p> <p><b>b)</b>  <math>\frac{3}{6} &lt; \frac{5}{6}</math></p> <p><b>2. Sample response:</b></p> <p> <math>\frac{1}{3} &lt; \frac{5}{12}</math></p>	<p><b>3. a)</b> <math>\frac{3}{10}, \frac{3}{8}, \frac{3}{4}</math>      <b>b)</b> <math>\frac{1}{9}, \frac{3}{9}, \frac{8}{9}</math></p> <p><b>c)</b> <math>\frac{1}{8}, \frac{9}{20}, \frac{11}{12}</math>      <b>d)</b> <math>\frac{4}{10}, \frac{5}{8}, \frac{3}{4}</math></p> <p><b>4.</b> Washing clothes; [<i>Sample response:</i> <math>\frac{4}{5} &gt; \frac{3}{4}</math> because <math>\frac{4}{5} = \frac{12}{15}</math> and <math>\frac{3}{4} = \frac{12}{16}</math> and <math>\frac{12}{15} &gt; \frac{12}{16}</math>.]</p> <p><b>5.</b> The basket that is <math>\frac{5}{8}</math> full has more oranges; [<i>Sample response:</i> <math>\frac{5}{8} = \frac{25}{40}</math> and <math>\frac{3}{5} = \frac{24}{40}</math> and <math>\frac{25}{40} &gt; \frac{24}{40}</math>]</p> <p><b>6. a)</b> 3      <b>b)</b> 3      <b>c)</b> 5      <b>d)</b> 3</p> <p><b>[7. Sample response:</b> When fractions have the same denominator, it means the parts are all the same size. You can look at the numerators to compare the number of parts.]</p>

## Supporting Students

### Struggling students

- Some students might struggle with **question 2**. Suggest that they draw another rectangle the same size as the given rectangle and mark it to show  $\frac{5}{12}$ .
- Struggling students might have difficulty with **question 6**. You may choose not to assign this question to those students.

### Enrichment

- You might ask students to find all the ways they can use the digits 2, 3, 4, and 6 to make this statement true:  
 $\frac{\square}{\square} < \frac{\square}{\square}$ .



## 1.1.3 EXPLORE: Adding and Subtracting Fractions

Curriculum Outcomes		Lesson Relevance
<b>6-B1 Addition and Subtraction: simple fractions with various denominators</b> <ul style="list-style-type: none"> <li>develop conceptual understanding of fraction addition and subtraction by exploring models (pattern blocks, fraction circles)</li> <li>solve fractions problems in context</li> </ul>		This optional exploration gives students an opportunity to develop their own strategies for adding and subtracting fractions before they are introduced to other people's strategies.
Pacing	Materials	Prerequisites
40 min	<ul style="list-style-type: none"> <li>Pattern blocks, or Pattern Block Fraction Pieces (BLM)</li> </ul>	<ul style="list-style-type: none"> <li>identifying and representing fractions of a whole</li> </ul>

### Exploration

- Provide pattern blocks or Pattern Block Fraction Pieces (BLM) to pairs or small groups of students. Name the shapes with the students — H for hexagon, Tr for trapezoid, R for rhombus, and T for triangle.
- Invite students to work through the exploration in pairs or small groups. Read through the **parts A to C** with students before they begin the activity to make sure they understand what they are supposed to do. Tell them to stop when they have finished **part C**. Make sure they are progressing well before you ask them to complete the rest of the exploration.

While you observe students at work, you might ask questions such as the following:

- How many T pieces cover the R piece? The Tr piece?* (It takes 2 T pieces to cover the R piece and 3 T pieces to cover the Tr piece.)

- Why might you name the T piece  $\frac{1}{6}$ ?* (Because it takes 6 T pieces to make 1 whole H piece.)

- What fraction name could you give the Tr piece? The R piece? Are there other names you could have used?*

(I could call the Tr piece  $\frac{1}{2}$  because it takes 2 of them to cover the whole. I could call the R piece  $\frac{1}{3}$  because it takes 3 of them to cover the whole. I could also call the Tr piece  $\frac{3}{6}$  because it takes 3 T pieces to cover it. I could also call the R piece  $\frac{2}{6}$  because it takes 2 T pieces to cover it.)

- When you cover the Tr piece with an R piece and a T piece, why could you write any of these sentences:*

$\frac{1}{2} = \frac{1}{3} + \frac{1}{6}$ ,  $\frac{1}{2} - \frac{1}{3} = \frac{1}{6}$ , or  $\frac{1}{2} - \frac{1}{6} = \frac{1}{3}$ ? (I could think of putting together the two smaller pieces to make the larger piece or I could think of how much larger the large piece is than each of the smaller pieces.)

### Observe and Assess

As students work, notice the following:

- Do students write appropriate number sentences to describe their models?
- Do they correctly calculate sums and differences?
- Do they reasonably predict what will happen before they create the model?

## Share and Reflect

After students have had sufficient time to work through the exploration, they should form small groups to discuss their observations and discuss questions such as these.

- *When would you write an addition sentence?*
- *Why did you write a subtraction sentence when you covered a larger piece with a smaller piece? What does the answer to the subtraction represent?*
- *Why was it useful to cover all the pieces with triangles to write the addition and subtraction sentences?*

## Answers

A. One TR =  $\frac{1}{2}$ ; one R =  $\frac{1}{3}$ ; one T =  $\frac{1}{6}$ .

B. i) 5          ii) 4          iii) 3          iv) 5

C. i) i) one Tr + one R = five T

ii) One TR and one T is  $\frac{1}{2} + \frac{1}{6} = \frac{4}{6}$ .

One R and one T is  $\frac{1}{3} + \frac{1}{6} = \frac{3}{6}$ .

One R, one R, and one T is  $\frac{1}{3} + \frac{1}{3} + \frac{1}{6} = \frac{5}{6}$ .

D. i) 3          ii) 1          iii) 3

E. i) ii) One Tr – one R = one T

ii) One H – one TR =  $1 - \frac{1}{2} = \frac{3}{6}$  or  $\frac{1}{2}$

One H – (one R and one T) =  $1 - (\frac{1}{3} + \frac{1}{6}) = \frac{3}{6}$  or  $\frac{1}{2}$

## Supporting Students

### *Struggling students*

- Some students might be more successful if you lead them through **part A** and then have them label each piece with the correct fraction of H.

## 1.1.4 Adding Fractions

Curriculum Outcomes		Outcome relevance
<b>6-B1 Addition and Subtraction: simple fractions with various denominators</b> <ul style="list-style-type: none"> <li>develop conceptual understanding of fraction addition and subtraction by exploring models (pattern blocks, fraction circles)</li> <li>solve fraction problems in context</li> </ul>		Adding and subtracting fractions is an important skill for higher classes in math as well as for real-world situations. Students who understand why the procedures work the way they do will be better at applying addition and subtraction skills to problem situations.
Pacing	Materials	Prerequisites
1 h	<ul style="list-style-type: none"> <li>Fraction Strips (BLM)</li> <li>Scissors</li> <li>Grid paper or Small Grid Paper (BLM) (optional)</li> </ul>	<ul style="list-style-type: none"> <li>identifying fractions of a whole</li> </ul>

### Main Points to be Raised

- To add two fractions, each must be part of the same size whole.
- To add fractions with the same denominator, you need to count only the total number of parts that are used.
- To add fractions with different denominators, you can represent each with a fraction strip, lay the strips end to end, and find a single strip with the same total length.

### Try This — Introducing the Lesson

A. Allow students to try this alone or with a partner. While you observe students at work, you might ask questions such as the following:

- How do  $\frac{1}{3}$  and  $\frac{1}{4}$  compare to  $\frac{1}{2}$ ? (They are both less than  $\frac{1}{2}$ .)
- How much is  $\frac{1}{3} + \frac{1}{4}$  compared to  $\frac{1}{4} + \frac{1}{4}$ ? Why? ( $\frac{1}{3} + \frac{1}{4}$  is more because  $\frac{1}{3}$  is more than  $\frac{1}{4}$ .)
- Why is it harder to answer **part ii**) than **part i**)? (The measurements are not both cups or both teaspoons.)

*Note: Give each pair of students one set of fraction strips that is not cut up as well as a set of strips that have been cut up. If scissors are not readily available in your classroom you may gather scissors from around the school at the start of the unit, cut out the strips, and put them in envelopes that you can distribute as they are needed. If you are not able to use the strips, students can visualize sums using the strips shown on **page 11** of the student text, but this may be much more difficult for them than using the actual strips.*

### The Exposition — Presenting the Main Ideas

- Have students turn to the fraction strips shown on **page 11** in the student text. Point out the whole strip in row 1. Ask them how the second row shows that  $\frac{1}{2} + \frac{1}{2} = 1$  whole. Ask what addition the third row shows ( $\frac{1}{3} + \frac{1}{3} + \frac{1}{3} = 1$ ).
- Ask students how they think you might show  $\frac{1}{2} + \frac{1}{3}$ . Encourage them to see that you would lay a  $\frac{1}{3}$  strip end to end with a  $\frac{1}{2}$  strip and see that it matches the length of five  $\frac{1}{6}$  strips. For that reason, the total is  $\frac{5}{6}$ . Have them try it with their own strips by using pre-cut  $\frac{1}{2}$  and  $\frac{1}{3}$  strips and laying them down along the row with  $\frac{1}{6}$  strips that is not cut up.

- Have students look again at **page 11** to see how a similar strategy is used to show  $\frac{1}{2} + \frac{1}{4}$ , but this time one row is shown below the other.
- Tell students that addition can also be performed with other shapes, such as the circles on **page 10** of the student text, but that they will be working with the rectangular strips.

### Revisiting the Try This

- B.** Students can use a combination of number sense and the actual fraction strips to answer **part B**.
- C.** The purpose of **part C** is to emphasize the importance of adding fractions only when the wholes are the same.

### Using the Examples

- Work through **example 1** with the students. Point out that this example shows that not only can fraction circles and fraction strips be used to show fraction addition, but grids can also be used. The thinking indicates that the student started with a whole and divided it into eighths, but if he had had grid paper, he could simply have outlined 8 squares.
- Ask students to read through **example 2** on their own.

### Practising and Applying

#### Teaching points and tips

**Q 1:** Students can use the fraction strips if they wish, but they will probably be able to answer these questions by thinking about them like this:

$$\frac{3}{8} + \frac{2}{8} \text{ is } 3 \text{ eighths} + 2 \text{ eighths} = 5 \text{ eighths.}$$

**Q 2:** Students should work in pairs using pre-cut fraction strips as well as the uncut fraction strips

**Q 3:** Some students may benefit from using their fraction strips to model the pictures shown.

**Q 4:** Encourage students to use either their fraction strips or squares on a grid. If they use squares on a grid, they should make a rectangle of 6 squares and find different ways to colour 5 squares. They will need to use at least some fraction pairs with different denominators.

**Q 5:** This question will require a fair bit of exploration. Students should use their fraction strips. You may have them work in pairs.

**Q 6:** This question is designed to help students understand that you have to make sure the whole is the same before you add two fractions.

**Q 7 c):** Students might use two colours to show the  $\frac{1}{4}$  and  $\frac{3}{8}$  parts.

**Q 8:** It is important to avoid saying that it is impossible to add two fractions when the denominators are different because it is possible to do so if fraction strips are available.

#### Common errors

- If students are not careful about placing the fraction strips exactly end to end, they may not get the correct answers. Emphasize that they should take care.

#### Suggested assessment questions from Practising and Applying

<b>Question 2</b>	to see if students can model a fraction sum
<b>Question 3</b>	to see if students can identify a situation that shows a fraction sum
<b>Question 8</b>	to see if students can communicate about the difference in thinking between adding fractions with the same denominator and adding fractions with different denominators

## Answers

<p><b>A. Sample responses:</b></p> <p><b>i)</b> A bit more than <math>\frac{1}{2}</math> cup; Two <math>\frac{1}{4}</math> cups is <math>\frac{1}{2}</math> cup.</p> <p><math>\frac{1}{3}</math> is a bit more than <math>\frac{1}{4}</math>, so <math>\frac{1}{4} + \frac{1}{3}</math> has to be a bit more than <math>\frac{1}{2}</math>.</p> <p><b>ii)</b> Just a small bit more than <math>\frac{1}{3}</math>; <math>\frac{1}{2}</math> teaspoon is a lot smaller than <math>\frac{1}{3}</math> cup because a teaspoon is a lot smaller than a cup, so if she adds it to <math>\frac{1}{3}</math> cup it will not make much difference.</p>	<p><b>B. i) Sample response:</b></p> <p>Since <math>\frac{1}{3} &gt; \frac{1}{4}</math>, then <math>\frac{1}{3} + \frac{1}{4} &gt; \frac{1}{4} + \frac{1}{4} = \frac{2}{4}</math>;</p> <p>Since <math>\frac{1}{4} &lt; \frac{1}{3}</math>, then <math>\frac{1}{3} + \frac{1}{4} &lt; \frac{1}{3} + \frac{1}{3} = \frac{2}{3}</math>.</p> <p><b>ii) Yes; Sample response:</b></p> <p><math>\frac{7}{12}</math> is between <math>\frac{2}{4}</math> (which is <math>\frac{6}{12}</math>) and <math>\frac{2}{3}</math> (which is <math>\frac{8}{12}</math>).</p> <p><b>C.</b> You cannot add a fraction of one thing to a fraction of something else. To add fractions, they both have to be fractions of the same whole.</p>																				
<p><b>1. a)</b> <math>\frac{5}{8}</math>      <b>b)</b> <math>\frac{6}{8}</math>      <b>c)</b> <math>\frac{10}{10}</math>      <b>d)</b> <math>\frac{4}{5}</math></p> <p><b>2. a)</b> <math>\frac{7}{8}</math></p> <table border="1" data-bbox="261 787 630 911"> <tbody> <tr> <td><math>\frac{1}{4}</math></td> <td><math>\frac{1}{4}</math></td> <td><math>\frac{1}{4}</math></td> <td><math>\frac{1}{8}</math></td> </tr> <tr> <td><math>\frac{1}{8}</math></td> <td><math>\frac{1}{8}</math></td> <td><math>\frac{1}{8}</math></td> <td><math>\frac{1}{8}</math></td> </tr> </tbody> </table> <p><b>b)</b> <math>\frac{7}{12}</math></p> <table border="1" data-bbox="261 949 704 1073"> <tbody> <tr> <td><math>\frac{1}{12}</math></td> <td><math>\frac{1}{12}</math></td> <td><math>\frac{1}{12}</math></td> <td><math>\frac{1}{12}</math></td> <td><math>\frac{1}{12}</math></td> <td><math>\frac{1}{6}</math></td> </tr> <tr> <td><math>\frac{1}{12}</math></td> <td><math>\frac{1}{12}</math></td> <td><math>\frac{1}{12}</math></td> <td><math>\frac{1}{12}</math></td> <td><math>\frac{1}{12}</math></td> <td><math>\frac{1}{12}</math></td> </tr> </tbody> </table> <p><b>c)</b> <math>\frac{11}{12}</math>      <b>d)</b> <math>\frac{5}{6}</math></p> <p><b>3. a)</b> <math>\frac{3}{10} + \frac{2}{5} = \frac{7}{10}</math></p> <p><b>b)</b> <math>\frac{1}{6} + \frac{2}{3} = \frac{5}{6}</math></p> <p><b>c)</b> <math>\frac{2}{4} + \frac{1}{3} = \frac{5}{6}</math></p>	$\frac{1}{4}$	$\frac{1}{4}$	$\frac{1}{4}$	$\frac{1}{8}$	$\frac{1}{8}$	$\frac{1}{8}$	$\frac{1}{8}$	$\frac{1}{8}$	$\frac{1}{12}$	$\frac{1}{12}$	$\frac{1}{12}$	$\frac{1}{12}$	$\frac{1}{12}$	$\frac{1}{6}$	$\frac{1}{12}$	$\frac{1}{12}$	$\frac{1}{12}$	$\frac{1}{12}$	$\frac{1}{12}$	$\frac{1}{12}$	<p><b>4. Sample response:</b></p> <p><math>\frac{1}{6} + \frac{4}{6}</math>; <math>\frac{2}{6} + \frac{3}{6}</math>; <math>\frac{5}{12} + \frac{5}{12}</math>; <math>\frac{1}{3} + \frac{1}{2}</math>; <math>\frac{1}{12} + \frac{3}{4}</math></p> <p><b>5. Sample responses:</b></p> <p><b>a)</b> <math>\frac{2}{8} + \frac{1}{4} = \frac{1}{2}</math>      <b>b)</b> <math>\frac{1}{3} + \frac{1}{2} = \frac{5}{6}</math></p> <p><b>c)</b> <math>\frac{1}{3} + \frac{1}{4} = \frac{7}{12}</math>      <b>d)</b> <math>\frac{1}{2} + \frac{1}{4} = \frac{3}{4}</math></p> <p><b>6.</b> No; [Each fraction is a part of a different whole.]</p> <p><b>7. a)</b> Place counters on any 2 squares (or colour 2 squares).</p> <p><b>b)</b> Place counters on any 3 squares (or colour 3 squares).</p> <p><b>c)</b> Place counters on any 5 squares (or colour 2 squares one colour and 3 squares another colour).</p> <p><b>[8. Sample response:</b></p> <p>You only have to find the sum of the numerators because the parts are the same. With different denominators, you might need to use fraction strips.]</p>
$\frac{1}{4}$	$\frac{1}{4}$	$\frac{1}{4}$	$\frac{1}{8}$																		
$\frac{1}{8}$	$\frac{1}{8}$	$\frac{1}{8}$	$\frac{1}{8}$																		
$\frac{1}{12}$	$\frac{1}{12}$	$\frac{1}{12}$	$\frac{1}{12}$	$\frac{1}{12}$	$\frac{1}{6}$																
$\frac{1}{12}$	$\frac{1}{12}$	$\frac{1}{12}$	$\frac{1}{12}$	$\frac{1}{12}$	$\frac{1}{12}$																

## Supporting Students

### Struggling students

- If some students find it easier to use grids than fraction strips, allow them to switch to using grids. Most students will probably find the fraction strips easier.
- You may choose not to assign **question 5** to struggling students. You might also model one example for **question 7**.

### Enrichment

- Encourage students who are interested to create other questions like **question 5**. For example: *Is it possible to add fifths and halves to get fifths?*

## CONNECTIONS: Fractions between Fractions

• The fact that there is always another fraction between any two given fractions is a property of fractions called density. This property makes fractions different from integers; there is no integer between two adjacent integers, for example, between 3 and 4. It is always possible to create another fraction between two given fractions by adding the numerators to create the new numerator and adding the denominators to create the new denominator.

For example,  $\frac{3+7}{4+8} = \frac{10}{12} = \frac{5}{6}$  is between  $\frac{3}{4}$  and  $\frac{7}{8}$ .

• Have students turn to **page 14** in the student text. Point out how the diagram shows that  $\frac{2}{3}$  is between  $\frac{1}{2}$  and  $\frac{4}{5}$ . Write all three fractions on the board in order. Point out that the 2 in the numerator of  $\frac{2}{3}$  is between the 1 and the 4 in the other two numerators and that the 3 in the denominator of  $\frac{2}{3}$  is between the 2 and the 5 in the other two denominators.

• Explain that as they work through the connection, they will find out whether this is always true. Tell them that they should use the strategy of using a numerator between the two numerators and a denominator between the two denominators to create the fractions for **questions 1 and 2**.

### Answers

1. *Sample responses:*

a)  $\frac{3}{4}$  and  $\frac{7}{8}$

b)  $\frac{5}{6}$  and  $\frac{4}{7}$  (fractions between  $\frac{1}{2}$  and  $\frac{7}{8}$ )

2. *Sample response:*

$\frac{3}{9}$  and  $\frac{6}{6}$ ;

[3 is between 1 and 9, and 9 is between 2 and 10, but  $\frac{3}{9} < \frac{1}{2}$ .

6 is between 1 and 9, and 6 is between 2 and 10, but  $\frac{6}{6} > \frac{9}{10}$ .]

## 1.1.5 Subtracting Fractions

Curriculum Outcomes		Outcome relevance
<b>6-B1 Addition and Subtraction: simple fractions with various denominators</b> <ul style="list-style-type: none"> <li>develop conceptual understanding of fraction addition and subtraction by exploring models (pattern blocks, fraction circles)</li> <li>solve fraction problems in context</li> </ul>		Adding and subtracting fractions is an important skill for higher classes in math as well as for real-world situations. Students who understand why the procedures work the way they do will be better at applying addition and subtraction skills to problem situations.
Pacing	Materials	Prerequisites
1 h	<ul style="list-style-type: none"> <li>Fraction Strips (BLM)</li> <li>Grid paper or Small Grid Paper (BLM) (optional)</li> </ul>	<ul style="list-style-type: none"> <li>representing subtraction as how much more one item is than another</li> <li>identifying fractions of a whole</li> </ul>

### Main Points to be Raised

- To subtract two fractions, each must be part of the same whole.
- When you subtract fractions with the same denominator, you count how many more parts one fraction has than the other.
- To subtract fractions with different denominators, you can represent each fraction with a fraction strip, lay them both down starting at the same base line and then find the strip that must be added to the shorter strip to make it the same length as the longer strip.

### Try This — Introducing the Lesson

A. Allow students to try this alone. While you observe students at work, you might ask questions such as the following:

- What fraction tells the part that is bananas? ( $\frac{3}{5}$ )
- What fraction tells the part that is apples? ( $\frac{2}{5}$ )
- How do you know that the bananas part is  $\frac{1}{5}$  greater? ( $3 - 1 = 2$  and so 3 fifths  $-$  1 fifths  $=$  2 fifths.)

### The Exposition — Presenting the Main Ideas

- Provide the cut-up fraction strips used in **lesson 1.1.4** to pairs of students.
- Ask students why you can think of  $6 - 2$  has how much more 6 is than 2. Tell them that you will use the same idea with fractions.
- Ask students how they think you might show  $\frac{1}{2} - \frac{1}{3}$ . Encourage them to see that you would lay a  $\frac{1}{3}$  strip below a  $\frac{1}{2}$  strip, lining up the left edges, and see how much longer the  $\frac{1}{2}$  strip is. Explain that they can search among their strips for a strip that fits exactly in the extra space. They will discover that the  $\frac{1}{6}$  strip will work. Explain why you might write the equation  $\frac{1}{2} - \frac{1}{3} = \frac{1}{6}$ .
- Draw students' attention to the diagram on **page 16** of the student text that shows why  $\frac{1}{2} - \frac{1}{4} = \frac{1}{4}$ . It is similar to what is described above.
- Have students turn back to **page 15** to show how both the strip diagram and the fraction circle diagram also show a subtraction by looking at how much more one fraction is than another.

## Revisiting the Try This

**B.** Encourage students to represent the subtraction with the strips to see that they get the same answer as they got for **part A**.

### Using the Examples

- Pose the problem from **example 1** on the board. Ask students to try it with their fraction strips and then check their answers against the solution and thinking in the text. Indicate that it is not necessary to use the 1 whole strip, but that it does give further confirmation that the answer makes sense.

- Lead students through **example 2** showing how outlining 8 squares on a grid allows them to model  $\frac{5}{8} - \frac{2}{8}$ .

Point out that this time the student used a take-away meaning for subtraction.

### Practising and Applying

#### Teaching points and tips

**Q 1:** Students may do these with or without fraction strips or grids.

**Q 3:** Some students will need to use the models to duplicate what is on the page and others will not.

**Q 4:** Students could use fraction strips, or they might look at the fraction strips on **page 11** of the student text.

**Q 5:** Students should experiment with their fraction strips to answer this question. This is more difficult than many questions used for assessment, but it is important to see how students perform in a problem-solving situation.

**Q 6:** This question is designed to reinforce the need to consider the wholes when subtracting two fractions.

**Q 7:** Ask students why a fraction with 12 squares is suitable for these questions.

**Q 8:** You may wish to discuss this question as a whole class.

#### Common errors

- Students need to line up their strips carefully to ensure that they get the correct answers.
- Some students will subtract numerators and subtract denominators without using the strips; normally their answers will be incorrect if they do this. It is important to emphasize the value of the strips.

#### Suggested assessment questions from Practising and Applying

<b>Question 2</b>	to see if students can subtract fractions using concrete materials
<b>Question 4</b>	to see if students can create a subtraction with a given difference
<b>Question 5</b>	to see if students can develop strategies to describe a fraction situation

### Answers

*Note: For any of the answers, equivalent fractions could be used.*

<p><b>A. i)</b> The fraction that is bananas is greater.</p> <p><b>ii)</b> <math>\frac{1}{5}</math></p>	<p><b>B.</b> <math>\frac{3}{5} - \frac{2}{5} = \frac{1}{5}</math></p>																
<p><b>1. a)</b> <math>\frac{1}{8}</math>      <b>b)</b> <math>\frac{4}{8}</math>      <b>c)</b> <math>\frac{4}{10}</math>      <b>d)</b> <math>\frac{2}{5}</math></p> <p><b>2. a)</b> <math>\frac{5}{8}</math></p> <table border="1" style="display: inline-table; margin-left: 20px;"> <tr> <td><math>\frac{1}{4}</math></td> <td><math>\frac{1}{4}</math></td> <td><math>\frac{1}{4}</math></td> </tr> <tr> <td><math>\frac{1}{8}</math></td> <td><math>\frac{1}{8}</math></td> <td><math>\frac{1}{8}</math></td> </tr> </table>	$\frac{1}{4}$	$\frac{1}{4}$	$\frac{1}{4}$	$\frac{1}{8}$	$\frac{1}{8}$	$\frac{1}{8}$	<p><b>b)</b> <math>\frac{3}{12}</math> or <math>\frac{1}{4}</math></p> <table border="1" style="display: inline-table; margin-left: 20px;"> <tr> <td><math>\frac{1}{12}</math></td> <td><math>\frac{1}{12}</math></td> <td><math>\frac{1}{12}</math></td> <td><math>\frac{1}{12}</math></td> <td><math>\frac{1}{12}</math></td> </tr> <tr> <td colspan="2"><math>\frac{1}{6}</math></td> <td colspan="3"><math>\frac{1}{4}</math></td> </tr> </table> <p><b>c)</b> <math>\frac{5}{12}</math>      <b>d)</b> <math>\frac{1}{6}</math></p>	$\frac{1}{12}$	$\frac{1}{12}$	$\frac{1}{12}$	$\frac{1}{12}$	$\frac{1}{12}$	$\frac{1}{6}$		$\frac{1}{4}$		
$\frac{1}{4}$	$\frac{1}{4}$	$\frac{1}{4}$															
$\frac{1}{8}$	$\frac{1}{8}$	$\frac{1}{8}$															
$\frac{1}{12}$	$\frac{1}{12}$	$\frac{1}{12}$	$\frac{1}{12}$	$\frac{1}{12}$													
$\frac{1}{6}$		$\frac{1}{4}$															



<p><b>3. a)</b> <math>\frac{2}{5} - \frac{3}{10} = \frac{1}{10}</math></p> <p><b>b)</b> <math>\frac{2}{4} - \frac{1}{8} = \frac{3}{8}</math></p> <p><b>c)</b> <math>\frac{2}{4} - \frac{1}{3} = \frac{1}{6}</math></p> <p><b>4. Sample response:</b>  <math>\frac{2}{3} - \frac{1}{3}; 1 - \frac{2}{3}; \frac{11}{12} - \frac{7}{12}; \frac{10}{12} - \frac{1}{2}; \frac{3}{4} - \frac{5}{12}</math>.</p> <p><b>5. Sample responses:</b></p> <p><b>a)</b> <math>\frac{1}{3} - \frac{1}{4} = \frac{1}{12}</math></p> <p><b>b)</b> <math>\frac{2}{3} - \frac{2}{4} = \frac{1}{6}</math></p> <p><b>c)</b> <math>\frac{1}{2} - \frac{1}{4} = \frac{1}{4}</math></p> <p><b>d)</b> <math>\frac{1}{3} - \frac{2}{12} = \frac{1}{6}</math></p>	<p><b>6. No; [Sample response:</b>          If Kuenga's school has more students than Ugyen's, then more students are playing sports in Kuenga's school. But if Kuenga's school is small and Ugyen's school is big, there might be more students in <math>\frac{1}{3}</math> of Ugyen's school than in <math>\frac{2}{3}</math> of Kuenga's school.]</p> <p><b>7. a)</b> Place counters in any 3 squares.  <b>b)</b> Place counters in any 2 squares.  <b>c)</b> Place counters in any 3 squares (or colour 3 squares in the first row), and place counters in any 2 squares (or colour 2 squares in the second row). Compare the number of counters (or the number of coloured squares) in the two rows.          Or, put counters in any 3 squares and then take away 2 counters.</p> <p><b>[8. Sample response:</b>          If two fractions have the same denominator, you can count how many sections to take away, but if they have different denominators, you need to measure to see how much more one fraction is than another. Fraction strips help you measure.]</p>
--	--

## Supporting Students

### Struggling students

- Struggling students may have difficulty with **question 5**. You may need to support them by showing them how to do, for example, **part a)**, so that they can then try the other parts.
- Similarly, you might model one part of **question 7** and one solution to **question 4** so that they can continue successfully.

### Enrichment

- Encourage students to create questions like **question 5** for other students to solve.

For example, they might ask:

*Is it possible to subtract fifths from fourths and find the answer using the fraction strips you have?*

## Chapter 2 Relating Fractions and Decimals

### 1.2.1 Naming Fractions as Decimals

Curriculum Outcomes	Outcome relevance
<b>6-A3 Renaming: simple fractions and decimals</b> <ul style="list-style-type: none"><li>• use models to make the connection between fractions and division</li></ul> <b>6-A2 Comparing Fractions: develop procedures</b> <ul style="list-style-type: none"><li>• compare fractions using equivalent decimals</li></ul>	<ul style="list-style-type: none"><li>• Decimals are another form of fractions. It is important for students to be able to move easily between the two representations.</li><li>• Writing certain decimals as fractions supports what students have learned about adding and subtracting fractions.</li></ul>

Pacing	Materials	Prerequisites
1 h	<ul style="list-style-type: none"><li>• Hundredths Grids (BLM)</li></ul>	<ul style="list-style-type: none"><li>• identifying and representing decimal tenths and hundredths as fractions</li></ul>

#### Main Points to be Raised

- If an object is divided into 10 sections, you can represent its parts as decimal tenths.
- If an object is divided into 100 sections, you can represent its parts as decimal hundredths.
- You can write any decimal as a fraction. Sometimes the denominator is 10 or 100, but it could be another value, like 4.

#### Try This — Introducing the Lesson

A. Allow students to try this alone or with a partner. While you observe students at work, you might ask questions such as the following:

- *How many decimal places will your decimals have? Why?* (They will have two decimal places because a centimetre is one hundredth of a metre.)
- *Why is the whole number part of Dorji's jump height 0?* (95 cm is not even one full metre.)
- *Why did you write 1.02 and not 1.2?* (1.2 m is 1 m and 20 cm, not 1 m and 2 cm.)

#### The Exposition — Presenting the Main Ideas

- Ask students to open their texts to **page 19**. Have them look at the three diagrams presented. Make sure they understand why the decimals and fractions indicated represent the amounts shown. Mention how the diagram for 0.13 can be viewed as a certain number of hundredths or as the sum of one tenth and some hundredths.
- Turning to **page 20**, ask students why the diagram shows that 0.25 can also be written as  $\frac{1}{4}$ . Make sure they see that the grid could be divided into 4 equal parts, each part the same size as the shaded area. Make sure that they also recognize that what they know about equivalent fractions explains why  $\frac{25}{100} = \frac{1}{4}$ .

#### Revisiting the Try This

B. Students can use fractions with denominators of 100, or they might use equivalent fractions.

For example, they could use  $\frac{19}{20}$  instead of  $\frac{95}{100}$ .

#### Using the Examples

- Pose the questions in the example for students to try. They can then test their answers against the solution and thinking in the student text.

## Practising and Applying

### Teaching points and tips

**Q1:** Encourage students to write improper fractions rather than mixed numbers.

**Q2:** Students might answer this question by referring to the hundredths grid or by referring to the fractions or mixed numbers represented by each decimal.

**Q3:** Students might solve this problem by recognizing that  $\frac{1}{2} = \frac{50}{100}$  and  $0.8 = \frac{80}{100}$ , or they might compare the amounts as decimals.

**Q4:** Make sure students understand that there is a missing digit. The decimal could be 0.20, 0.21, 0.22, ..., or 0.29. Encourage them to use a hundredths grid to help them answer the question.

**Q5:** Some students are likely to notice that the number of decimal digits is the same in each case. Remind them that the question asks them to talk about the equivalent fractions.

**Q6:** Students could use two identical grids where one grid is divided into 10 rows (or columns) and the other into 10 rows of 10 small squares. Or, they might use a single grid and look at it in more than one way.

**Q7:** Students should think about equivalent fractions to help them answer **part b**).

### Common errors

• Students often have difficulty writing decimals for  $x$  hundredths if  $x < 10$ . They frequently write them as 0.1, 0.2, ..., 0.9 rather than as 0.01, 0.02, ..., 0.09. Encourage them to use diagrams to make sense of their answers. For example, for 0.04 and 0.4, have students model each. Draw to their attention the difference in the models.

### Suggested assessment questions from Practising and Applying

<b>Question 1</b>	to see if students can write a decimal as a fraction
<b>Question 4</b>	to see if students can use decimal equivalents to compare two fractions
<b>Question 6</b>	to see if students can explain the equivalence of two decimals

### Answers

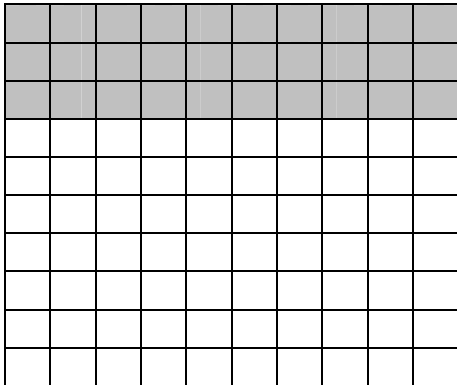
<b>A.</b> 1.38, 0.95, and 1.02.	<b>B.</b> $\frac{138}{100}$ , $\frac{95}{100}$ , and $\frac{102}{100}$
<p><b>1. a)</b> <math>\frac{8}{10}</math>      <b>b)</b> <math>\frac{8}{100}</math></p> <p><b>c)</b> <math>\frac{23}{10}</math>      <b>d)</b> <math>\frac{358}{10}</math></p> <p><b>2.</b> 1.2 is greater; [because 1.2 means 1 whole and 2 tenths, while 1.02 means 1 whole and 2 hundredths. Hundredths are smaller than tenths.]</p> <p><b>3.</b> C</p> <p><b>4.</b> Yes; [<math>\frac{19}{100} = 0.19</math> and <math>\frac{3}{10} = 0.3</math>. I know that 0.2 is between 0.19 and 0.3]</p> <p><b>5. Sample response:</b> They are all tenths.</p>	<p><b>6. Sample response:</b></p> <div style="text-align: center;">  </div> <p>[3 of 10 rows are shaded; that is 3 tenths. The 3 rows are also 30 squares; 30 out of 100 squares is 3 hundredths.]</p> <p><b>7. a) Sample response:</b> 0.50 <b>b) Sample response:</b> 4, 5, 10, 20, 25, 50, 100</p> <p><b>[8. Sample response:</b> You know the denominator is 10 or 100 and the numerator is the number you see after the decimal point.]</p>

## Supporting Students

### *Struggling students*

- Some students may have difficulty with questions like **question 4 or 7** that are more abstract. Pair up struggling students with other students for these questions.

### *Enrichment*

- Ask students to decide how many decimal hundredths less than 1 they can write as fractions with a denominator of 20 or less.

For example, they could write 0.2 as  $\frac{1}{5}$ .

## **GAME: Fraction Match**

This game is designed to allow students to practise recognizing the equivalence of a variety of forms of numbers:

- fractions and other fractions
- mixed numbers and improper fractions
- fractions and decimals

## 1.2.2 Naming Fractions as Decimals

Curriculum Outcomes		Outcome relevance
<b>6-A3 Renaming: simple fractions and decimals</b> <ul style="list-style-type: none"> <li>use models to make the connection between fractions and division</li> <li>investigate repeating decimals through concrete models (no symbolism)</li> </ul>		Decimals are another form of fractions. It is important for students to be able to move easily between the two representations. Writing fractions as decimals will make certain calculations easier for students.
Pacing	Materials	Prerequisites
1 h	<ul style="list-style-type: none"> <li>Hundredths Grids (BLM)</li> </ul>	<ul style="list-style-type: none"> <li>interpreting and modelling decimal tenths and hundredths</li> </ul>

### Main Points to be Raised

- You can write some fractions as decimals by shading fractions of a hundredths grid.
- Writing some fractions as decimals helps you write other fractions as decimals.

For example, if you know that  $\frac{1}{4} = 0.25$ , you know

that  $\frac{3}{4}$  must be 3 times as much, and  $3 \times 0.25 = 0.75$ .

### Try This — Introducing the Lesson

**A.** Allow students to try this alone or with a partner. While you observe students at work, you might ask questions such as the following:

- What fraction did you use to describe the classmates? (I used  $\frac{8}{40}$ , which is the same as  $\frac{1}{5}$ .)
- Did you compare the fraction for the classmates to 0.23 by changing 0.23 to a fraction or by changing your fraction to a decimal? (I changed  $\frac{1}{5}$  to the decimal 0.20.)
- Could you have compared them in a different way? (I could have changed 0.23 to  $\frac{23}{100}$  and  $\frac{1}{5}$  to  $\frac{20}{100}$  to compare.)

### The Exposition — Presenting the Main Ideas

- Work through the exposition on **pages 22 and 23** of the student text with the students. Make sure they understand why decimals like 0.20 can also be written as 0.2.
- To make sure students understand, ask them why  $\frac{3}{5}$  would be 0.60 (or 0.6) and why  $\frac{1}{8}$  is about 0.12.

### Revisiting the Try This

**B.** Students can use what they learned in the exposition to answer this question.

### Using the Examples

- Present the questions from the example on the board. Ask students to try them and then compare their solutions to the solution in the student text.

## Practising and Applying

### Teaching points and tips

**Q 1:** Make sure students realize they can either use hundredths grids or find an equivalent fraction if the denominator is not 10 or 100.

**Q 2:** Students can compare the values as fractions or rewrite them as equivalent decimals.

**Q 5:** This is the first opportunity for students to use equivalent fractions when the denominators are greater than 100.

**Q 6:** Encourage students to work in pairs to answer this question. Before they write anything down, they can try out their explanations on their partners.

### Common errors

- Some students write a fraction like  $\frac{3}{5}$  as the decimal .35 (or 0.35). Encourage them to shade a hundredths grid to show 0.35. Remind them that  $\frac{3}{5}$  means 3 parts out of 5. Ask them to show you the 5 equal parts of the grid and then to shade 3 of the parts. They should see that the shaded portion is more than 0.35 of the grid.

### Suggested assessment questions from Practising and Applying

<b>Question 1</b>	to see if students can write simple fractions as decimals
<b>Question 3</b>	to see if students can use what they know about the decimal equivalent for one fraction to help them write a decimal equivalent for a related fraction
<b>Question 4</b>	to see if students can distinguish between situations where fraction equivalents are exact and situations where they are not exact

### Answers

<b>A.</b> The fraction of Bhutanese households that have piped water indoors is greater.	<b>B. i)</b> 0.23 and $\frac{23}{100}$ <b>ii)</b> 0.20 or 0.2 and $\frac{8}{40}$ or $\frac{1}{5}$
<b>1. a)</b> 0.8 <b>b)</b> 0.08 <b>c)</b> 0.06 <b>d)</b> 0.5	<b>5. a)</b> 0.6 <b>b)</b> 0.1
<b>2. a)</b> $\frac{3}{10}$ <b>b)</b> $\frac{3}{4}$	<b>6. Sample responses:</b> <b>a)</b> $\frac{1}{10}$ , $\frac{1}{100}$ , $\frac{1}{2}$ , $\frac{1}{4}$ , and $\frac{1}{5}$ [• It is easy to write tenths and hundredths fractions as decimals because that is what decimals mean. • If you use a hundredths grid, it is easy to see that $\frac{1}{2}$ is 50 squares, $\frac{1}{4}$ is 25 squares, and $\frac{1}{5}$ is 20 squares. Once you know the number of squares, you can write that amount as hundredths.] <b>b)</b> $\frac{1}{3}$ , $\frac{1}{6}$ , and $\frac{1}{9}$ ; [It is not possible to divide the hundredths grid into these fractions and get a whole number of whole squares, so you cannot write them as hundredths or tenths.]
<b>3. Sample response:</b> $\frac{2}{5} = 0.2 + 0.2 = 0.4$ $\frac{3}{5} = 0.4 + 0.2 = 0.6$ $\frac{4}{5} = 0.4 + 0.4 = 0.8$ <b>[4. Sample response:</b> If 0.33 were exactly one third, then a whole would be $3 \times 0.33 = 0.99$ or 99 squares in a hundredths grid; a whole is 1 or 100 squares.]	

## Supporting Students

### Struggling students

- Struggling students may have difficulty with **question 4**. Encourage them to use a grid model to explain.

### Enrichment

- Students might try to figure out which fractions with denominators between 100 and 200 they would find easy to write as decimals.

# UNIT 1 Revision

Pacing	Materials
2 h	<ul style="list-style-type: none"> <li>• Fraction Strips (BLM)</li> <li>• Hundredths Grids (BLM)</li> </ul>

Question(s)	Related Lesson(s)
1 – 3	Lesson 1.1.1
4 – 7	Lesson 1.1.2
8 – 10	Lesson 1.1.4
11 and 12	Lesson 1.1.5
13 – 15	Lesson 1.2.1
16 and 17	Lesson 1.2.2

## Revision Tips

**Q 3 b):** You may need to help students see that the fraction part of the mixed number must have a numerator of 1.

**Q 5:** Sometimes students mistakenly write the order from greatest to least. If they have done that, ask them to explain why, for example,  $\frac{4}{7}$  is least. They may notice the error on their own.

**Q 6:** Observe whether students use a variety of different strategies rather than always using the same strategy. Different strategies are more efficient for different parts of the question.

**Q 8 and 11:** Provide fraction strips for students to work with.

**Q 15:** Students are likely to rewrite the fraction as a decimal, but they could choose to rewrite the decimals as fractions.

## Answers

1. a) $5\frac{2}{3}$	b) $2\frac{2}{5}$	c) $3\frac{2}{4}$	6. a) $\frac{3}{8}$	b) $\frac{2}{7}$
2. a) $\frac{5}{2}$	b) $\frac{21}{4}$	c) $\frac{17}{10}$	c) $\frac{49}{50}$	d) $\frac{22}{100}$
3. a) 8	b) <i>Sample response:</i> $3\frac{1}{4}$		7. Kinley	
4. a) $\frac{2}{3} > \frac{1}{6}$	b) $\frac{1}{2} < \frac{5}{6}$		8. a) $\frac{11}{12}$	b) $\frac{5}{12}$
5. a) $\frac{2}{9}, \frac{1}{3}, \frac{4}{9}, \frac{4}{7}$			c) $\frac{3}{4}$	d) $\frac{3}{4}$
b) $\frac{2}{5}, \frac{4}{9}, \frac{14}{20}, \frac{7}{9}$			9. a) $\frac{2}{5} + \frac{5}{10} = \frac{9}{10}$	b) $\frac{1}{12} + \frac{2}{3} = \frac{3}{4}$
			10. <i>Sample response:</i>	
			$\frac{1}{4} + \frac{1}{2}; \frac{1}{12} + \frac{2}{3}; \frac{1}{3} + \frac{5}{12}$ .	

**Answers [Continued]**

<b>11. a)</b> $\frac{3}{4}$	<b>b)</b> $\frac{1}{12}$	<b>c)</b> $\frac{7}{12}$	<b>d)</b> $\frac{1}{12}$	<b>14. Sample response:</b> They are the same because both are between 3 and 4 and both have digits of 3 and 5. They are different because $3.5 > 3.05$ . 3.5 is 3 wholes and 5 tenths and 3.05 is 3 wholes and 5 hundredths.
<b>12. a)</b> $\frac{11}{12} - \frac{2}{3} = \frac{3}{12}$ or $\frac{1}{4}$				<b>15. A</b>
<b>b)</b> $\frac{4}{5} - \frac{3}{10} = \frac{5}{10}$ or $\frac{1}{2}$				<b>16. a)</b> 0.21 <b>b)</b> 0.6 <b>c)</b> 0.35 <b>d)</b> 0.8
<b>13. a)</b> $\frac{4}{10}$ (or $\frac{2}{5}$ )	<b>b)</b> $\frac{26}{100}$ (or $\frac{13}{50}$ )			<b>17. Sample response:</b> $\frac{3}{100} = 0.03$ ; $\frac{3}{10} = 0.3$ ; $\frac{3}{5} = 0.6$ ; $\frac{3}{4} = 0.75$
<b>c)</b> $\frac{28}{10}$ (or $\frac{14}{5}$ )	<b>d)</b> $\frac{175}{100}$ (or $\frac{7}{4}$ )			



## UNIT 1 Fractions and Decimals Test

1. Write the improper fraction as a mixed number. Write each mixed number as an improper fraction.

a)  $2\frac{3}{5}$       b)  $\frac{18}{7}$       c)  $5\frac{2}{3}$

2. Which value in **question 1** is greatest? How do you know?

3. Chandra's favourite chocolate bar has 10 sections.

a) How many chocolate bars did he eat if he ate 38 sections?

b) One of Chandra's chocolate bars has 4 sections left. Use a mixed number to tell how many bars he might have eaten.

4. What fraction comparison does each model show?

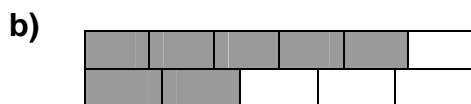
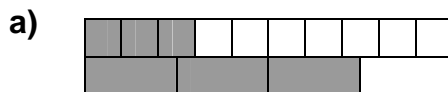

5. Draw a picture to show why  $\frac{2}{3} < \frac{3}{4}$ .

6. Use fraction strips to find each. Sketch what your strips look like.

a)  $\frac{1}{6} + \frac{5}{12}$       b)  $\frac{7}{8} - \frac{1}{2}$

7. Rinzin baked two identical cakes.

- She cut the first cake into 6 equal pieces. Her friends ate 5 pieces.

- She cut the second cake into 12 equal pieces. Her friends ate 8 pieces.

Write and solve a number sentence that you could use to find how much more cake was left over from the second cake than from the first cake.

8. a) The answer to an addition is  $\frac{2}{3}$ .

What two fractions, with different denominators, could have been added?

b) The answer to a subtraction is  $\frac{2}{3}$ .

What two fractions, with different denominators, could have been subtracted?

9. Write each as a single fraction.

a) 0.37      b) 0.75  
c) 1.3      d) 2.60

10. Write 0.23 as the sum of two fractions.

11. Write each as a decimal.

a)  $\frac{4}{100}$       b)  $\frac{2}{5}$       c)  $\frac{8}{50}$

12. Why is it easier to write  $\frac{2}{5}$  as a decimal than to write  $\frac{2}{9}$  as a decimal?

# UNIT 1 Test

Pacing	Materials
1 h	<ul style="list-style-type: none"> <li>Fraction Strips (BLM)</li> <li>Hundredths Grids (BLM) (optional)</li> </ul>

Question(s)	Related Lesson(s)
1 and 3	Lesson 1.1.1
2 and 4	Lesson 1.1.2
6 – 8	Lessons 1.1.4 and 1.1.5
9 and 10	Lesson 1.2.1
11 and 12	Lesson 1.2.2

Select questions to assign according to the time available.

## Answers

<p><b>1. a)</b> <math>\frac{13}{5}</math>      <b>b)</b> <math>2\frac{4}{7}</math>      <b>c)</b> <math>\frac{17}{3}</math></p> <p><b>2. c)</b> is greatest; <i>Sample response:</i> It is greater than 5 and the others are less than 5.</p> <p><b>3. a)</b> <math>3\frac{8}{10}</math>      <b>b) Sample response:</b> <math>4\frac{6}{10}</math></p> <p><b>4. a)</b> <math>\frac{3}{10} &lt; \frac{3}{4}</math>      <b>b)</b> <math>\frac{5}{6} &gt; \frac{2}{5}</math></p> <p><b>5. Sample response:</b></p> <div style="border: 1px solid black; width: 100%; height: 20px; margin: 5px 0;"></div> <div style="border: 1px solid black; width: 100%; height: 20px; margin: 5px 0;"></div> <p><b>6. a)</b> <math>\frac{7}{12}</math></p> <table border="1" style="width: 100%; text-align: center; border-collapse: collapse; margin: 5px 0;"> <tbody> <tr> <td><math>\frac{1}{6}</math></td><td><math>\frac{1}{12}</math></td><td><math>\frac{1}{12}</math></td><td><math>\frac{1}{12}</math></td><td><math>\frac{1}{12}</math></td><td><math>\frac{1}{12}</math></td><td><math>\frac{1}{12}</math></td> </tr> <tr> <td><math>\frac{1}{12}</math></td><td><math>\frac{1}{12}</math></td><td><math>\frac{1}{12}</math></td><td><math>\frac{1}{12}</math></td><td><math>\frac{1}{12}</math></td><td><math>\frac{1}{12}</math></td><td><math>\frac{1}{12}</math></td> </tr> </tbody> </table> <p><b>b)</b> <math>\frac{3}{8}</math></p> <table border="1" style="width: 100%; text-align: center; border-collapse: collapse; margin: 5px 0;"> <tbody> <tr> <td><math>\frac{1}{8}</math></td><td><math>\frac{1}{8}</math></td><td><math>\frac{1}{8}</math></td><td><math>\frac{1}{8}</math></td><td><math>\frac{1}{8}</math></td><td><math>\frac{1}{8}</math></td><td><math>\frac{1}{8}</math></td> </tr> <tr> <td colspan="4"><math>\frac{1}{2}</math></td><td><math>\frac{1}{8}</math></td><td><math>\frac{1}{8}</math></td><td><math>\frac{1}{8}</math></td> </tr> </tbody> </table>	$\frac{1}{6}$	$\frac{1}{12}$	$\frac{1}{12}$	$\frac{1}{12}$	$\frac{1}{12}$	$\frac{1}{12}$	$\frac{1}{12}$	$\frac{1}{12}$	$\frac{1}{12}$	$\frac{1}{12}$	$\frac{1}{12}$	$\frac{1}{12}$	$\frac{1}{12}$	$\frac{1}{12}$	$\frac{1}{8}$	$\frac{1}{8}$	$\frac{1}{8}$	$\frac{1}{8}$	$\frac{1}{8}$	$\frac{1}{8}$	$\frac{1}{8}$	$\frac{1}{2}$				$\frac{1}{8}$	$\frac{1}{8}$	$\frac{1}{8}$	<p><b>7.</b> <math>\frac{4}{12} - \frac{1}{6} = \frac{1}{6}</math></p> <p>There was <math>\frac{1}{6}</math> more left over from the second cake than from the first cake.</p> <p><b>8. Sample responses:</b></p> <p><b>a)</b> <math>\frac{1}{2} + \frac{1}{6}</math>      <b>b)</b> <math>\frac{11}{12} - \frac{1}{4}</math></p> <p><b>9. Note:</b> <i>Equivalent fractions can also be used.</i></p> <p><b>a)</b> <math>\frac{37}{100}</math>      <b>b)</b> <math>\frac{3}{4}</math></p> <p><b>c)</b> <math>\frac{13}{10}</math>      <b>d)</b> <math>\frac{26}{10}</math></p> <p><b>10. Sample response:</b> <math>\frac{2}{10} + \frac{3}{100}</math></p> <p><b>11. a)</b> 0.04      <b>b)</b> 0.4      <b>c)</b> 0.16</p> <p><b>12. Sample response:</b> You can rewrite <math>\frac{2}{5}</math> as hundredths, but you cannot write <math>\frac{2}{9}</math> as an exact number of hundredths.</p>
$\frac{1}{6}$	$\frac{1}{12}$	$\frac{1}{12}$	$\frac{1}{12}$	$\frac{1}{12}$	$\frac{1}{12}$	$\frac{1}{12}$																							
$\frac{1}{12}$	$\frac{1}{12}$	$\frac{1}{12}$	$\frac{1}{12}$	$\frac{1}{12}$	$\frac{1}{12}$	$\frac{1}{12}$																							
$\frac{1}{8}$	$\frac{1}{8}$	$\frac{1}{8}$	$\frac{1}{8}$	$\frac{1}{8}$	$\frac{1}{8}$	$\frac{1}{8}$																							
$\frac{1}{2}$				$\frac{1}{8}$	$\frac{1}{8}$	$\frac{1}{8}$																							

## UNIT 1 Performance Task — Measuring Cups

Dechen wants to make Kewa Datshi. Part of the recipe is shown to the right.

**A. i)** Dechen can only find a  $\frac{1}{2}$ -cup measuring cup.

Will the cheese and the onions fit together into a  $\frac{1}{2}$ -cup measure? Explain your thinking.

**ii)** If Dechen puts only the cheese into the  $\frac{1}{2}$ -cup measuring cup, how much space is left in the cup? Show your thinking.

**iii)** If Dechen puts only the onions in the  $\frac{1}{2}$ -cup measuring cup, how much space is left in the cup? Show your thinking.

**B. i)** How do you know that the recipe calls for more cheese than onions?

**ii)** How much more cheese is needed than onions?

**C.** Suppose Dechen rewrites the recipe using decimals instead of fractions. What decimals should she use?

**D.** If Dechen makes 5 times as much as the recipe shows, how many cups of cheese will she use? Write your answer as a mixed number.

**E.** Create your own recipe using fractions. Write a word problem that could be solved by adding or subtracting the fractions in the recipe. Solve your problem.

### Kewa Datshi

4 potatoes

$\frac{1}{3}$  cup of cheese

$\frac{1}{4}$  cup of chopped red onions

# UNIT 1 Performance Task

Curriculum Outcomes Assessed	Pacing	Materials
<b>6-A1</b> Renaming: mixed numbers and improper fractions <b>6-A2</b> Comparing Fractions: develop procedures <b>6-A3</b> Renaming: simple fractions and decimals <b>6-B1</b> Addition and Subtraction: simple fractions with various denominators	1 h	• Fraction Strips (BLM)

## How to Use This Performance Task

- You might use this task as a rich problem to assess student understanding of a number of outcomes in this unit. It could replace or supplement the unit test.
- It could also be used as enrichment material for some students.
- You can assess performance on the task using the rubric on the next page.

## Sample Solution

<p><b>A. i)</b> No; <math>\frac{1}{4} + \frac{1}{3} = \frac{7}{12}</math> and that is more than <math>\frac{1}{2}</math>.</p> <p><b>ii)</b> <math>\frac{1}{6}</math> cup</p> <table border="1" style="margin-left: 20px;"> <tr> <td colspan="2" style="text-align: center;"><math>\frac{1}{2}</math></td> </tr> <tr> <td style="text-align: center;"><math>\frac{1}{3}</math></td> <td style="text-align: center;"><math>\frac{1}{6}</math></td> </tr> </table> <p><b>iii)</b> <math>\frac{1}{4}</math> cup</p> <table border="1" style="margin-left: 20px;"> <tr> <td colspan="2" style="text-align: center;"><math>\frac{1}{2}</math></td> </tr> <tr> <td style="text-align: center;"><math>\frac{1}{4}</math></td> <td style="text-align: center;"><math>\frac{1}{4}</math></td> </tr> </table> <p><b>B. i)</b> I know <math>\frac{1}{3} &gt; \frac{1}{4}</math> because thirds pieces are bigger than fourths pieces.</p> <p><b>ii)</b> <math>\frac{1}{3} - \frac{1}{4} = \frac{1}{12}</math></p>	$\frac{1}{2}$		$\frac{1}{3}$	$\frac{1}{6}$	$\frac{1}{2}$		$\frac{1}{4}$	$\frac{1}{4}$	<p><b>C.</b> 4 potatoes, 0.33 cup of cheese, and 0.25 cup of onions.</p> <p><b>D.</b> <math>1\frac{2}{3}</math> cups</p> <p><b>E.</b> A recipe uses <math>\frac{2}{3}</math> cup of cheese and <math>\frac{1}{4}</math> cup of onions. If both were put into the same 1-cup measure, how much of the cup would they fill? (<math>\frac{2}{3} + \frac{1}{4} = \frac{11}{12}</math>)</p> <table border="1" style="margin-left: 20px;"> <tr> <td colspan="4" style="text-align: center;"><math>\frac{1}{3}</math></td> <td colspan="4" style="text-align: center;"><math>\frac{1}{3}</math></td> <td colspan="4" style="text-align: center;"><math>\frac{1}{4}</math></td> </tr> <tr> <td><math>\frac{1}{12}</math></td><td><math>\frac{1}{12}</math></td><td><math>\frac{1}{12}</math></td><td><math>\frac{1}{12}</math></td> <td><math>\frac{1}{12}</math></td><td><math>\frac{1}{12}</math></td><td><math>\frac{1}{12}</math></td><td><math>\frac{1}{12}</math></td> <td><math>\frac{1}{12}</math></td><td><math>\frac{1}{12}</math></td><td><math>\frac{1}{12}</math></td><td><math>\frac{1}{12}</math></td> </tr> <tr> <td colspan="12" style="text-align: center;">1</td> </tr> </table>	$\frac{1}{3}$				$\frac{1}{3}$				$\frac{1}{4}$				$\frac{1}{12}$	$\frac{1}{12}$	$\frac{1}{12}$	$\frac{1}{12}$	$\frac{1}{12}$	$\frac{1}{12}$	$\frac{1}{12}$	$\frac{1}{12}$	$\frac{1}{12}$	$\frac{1}{12}$	$\frac{1}{12}$	$\frac{1}{12}$	1											
$\frac{1}{2}$																																													
$\frac{1}{3}$	$\frac{1}{6}$																																												
$\frac{1}{2}$																																													
$\frac{1}{4}$	$\frac{1}{4}$																																												
$\frac{1}{3}$				$\frac{1}{3}$				$\frac{1}{4}$																																					
$\frac{1}{12}$	$\frac{1}{12}$	$\frac{1}{12}$	$\frac{1}{12}$	$\frac{1}{12}$	$\frac{1}{12}$	$\frac{1}{12}$	$\frac{1}{12}$	$\frac{1}{12}$	$\frac{1}{12}$	$\frac{1}{12}$	$\frac{1}{12}$																																		
1																																													

## UNIT 1 Performance Task Assessment Rubric

<i>The student</i>	<b>Level 4</b>	<b>Level 3</b>	<b>Level 2</b>	<b>Level 1</b>
<b>Adds and subtracts fractions</b>	Efficiently and accurately models and interprets fraction sums and differences	Correctly models and interprets most fraction sums and differences	Correctly models and interprets some fraction sums and differences	Has difficulty modelling and interpreting fraction sums and differences
<b>Compares fractions, uses mixed numbers, and relates fractions to decimals</b>	Efficiently and accurately compares fractions, writes improper fractions as mixed numbers, and writes equivalent decimals for fractions	Correctly compares fractions, writes improper fractions as mixed numbers, and writes equivalent decimals for fractions for the most part	Performs only some of these tasks correctly: comparing fractions, writing improper fractions as mixed numbers, and writing equivalent decimals for fractions	Has difficulty comparing fractions, writing improper fractions as mixed numbers, and writing equivalent decimals for fractions
<b>Creates and solves problems</b>	Applies appropriate operations to solve given fraction problems, creates a clear and appropriate problem that is solved using addition or subtraction of fractions, and solves it clearly and completely	Applies appropriate operations to solve most of the given fraction problems, creates an appropriate problem that is solved using addition or subtraction of fractions, and solves it correctly	Solves some fraction addition and subtraction of fraction problems but has difficulty with others; solutions are mostly correct but not always fully explained	Has difficulty solving many addition and subtraction problems involving fractions

# UNIT 1 Blackline Masters

## BLM 1 Fraction Match Game Cards

$\frac{1}{2}$	0.35	$1\frac{2}{3}$	$\frac{2}{5} + \frac{2}{5}$	$\frac{12}{3}$	0.23
4	$\frac{4}{5}$	$\frac{4}{6}$	$\frac{5}{3}$	$3\frac{3}{4}$	$\frac{4}{8}$
$\frac{5}{8}$	$4\frac{1}{2}$	0.5	$\frac{9}{2}$	$\frac{2}{8} + \frac{3}{8}$	0.6
$\frac{15}{4}$	$\frac{7}{8} - \frac{3}{8}$	$\frac{6}{10}$	$\frac{23}{100}$	$\frac{3}{10} + \frac{5}{100}$	$\frac{5}{6} - \frac{1}{6}$

## BLM 2 Fraction Strips

1											
$\frac{1}{2}$						$\frac{1}{2}$					
$\frac{1}{3}$				$\frac{1}{3}$				$\frac{1}{3}$			
$\frac{1}{4}$			$\frac{1}{4}$			$\frac{1}{4}$			$\frac{1}{4}$		
$\frac{1}{5}$		$\frac{1}{5}$		$\frac{1}{5}$		$\frac{1}{5}$		$\frac{1}{5}$		$\frac{1}{5}$	
$\frac{1}{6}$		$\frac{1}{6}$		$\frac{1}{6}$		$\frac{1}{6}$		$\frac{1}{6}$		$\frac{1}{6}$	
$\frac{1}{8}$	$\frac{1}{8}$	$\frac{1}{8}$	$\frac{1}{8}$	$\frac{1}{8}$	$\frac{1}{8}$	$\frac{1}{8}$	$\frac{1}{8}$	$\frac{1}{8}$	$\frac{1}{8}$	$\frac{1}{8}$	$\frac{1}{8}$
$\frac{1}{9}$	$\frac{1}{9}$	$\frac{1}{9}$	$\frac{1}{9}$	$\frac{1}{9}$	$\frac{1}{9}$	$\frac{1}{9}$	$\frac{1}{9}$	$\frac{1}{9}$	$\frac{1}{9}$	$\frac{1}{9}$	$\frac{1}{9}$
$\frac{1}{10}$	$\frac{1}{10}$	$\frac{1}{10}$	$\frac{1}{10}$	$\frac{1}{10}$	$\frac{1}{10}$	$\frac{1}{10}$	$\frac{1}{10}$	$\frac{1}{10}$	$\frac{1}{10}$	$\frac{1}{10}$	$\frac{1}{10}$
$\frac{1}{12}$	$\frac{1}{12}$	$\frac{1}{12}$	$\frac{1}{12}$	$\frac{1}{12}$	$\frac{1}{12}$	$\frac{1}{12}$	$\frac{1}{12}$	$\frac{1}{12}$	$\frac{1}{12}$	$\frac{1}{12}$	$\frac{1}{12}$

**BLM 3 Pattern Block Fraction Pieces**

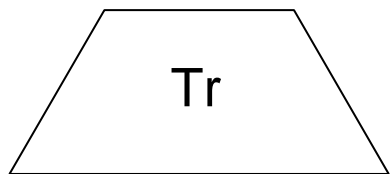
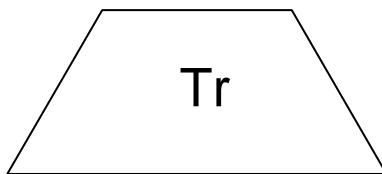
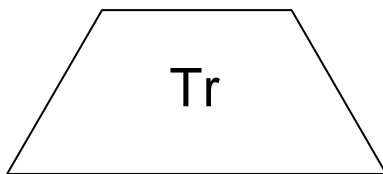
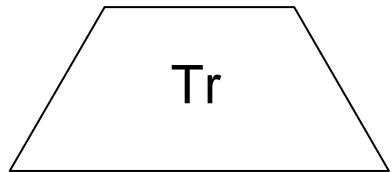
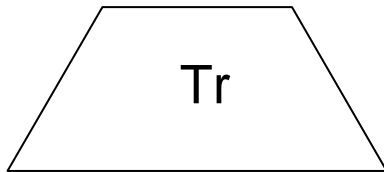
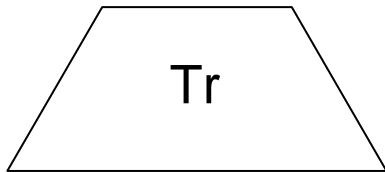
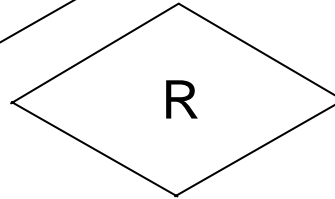
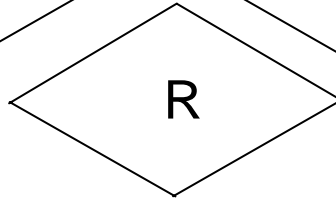
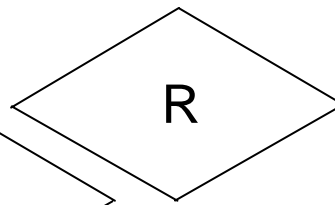
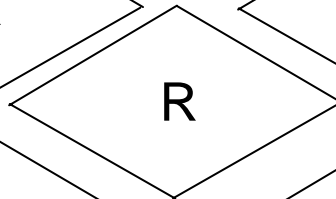
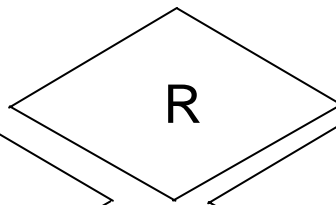
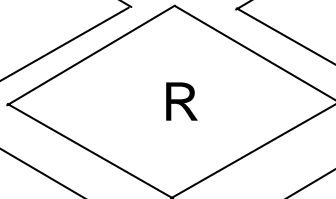
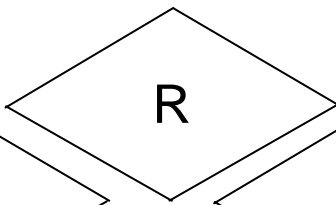
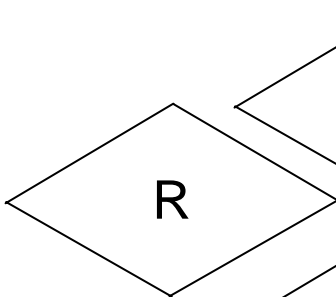
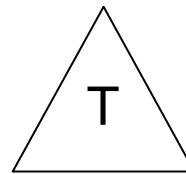
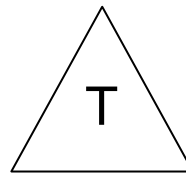
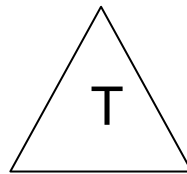
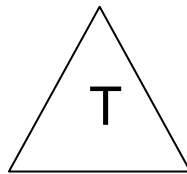
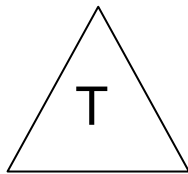
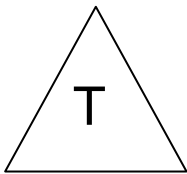
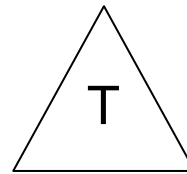
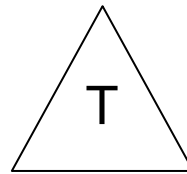
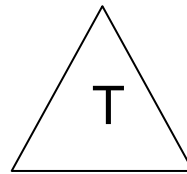
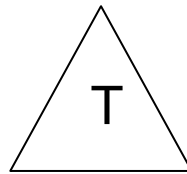
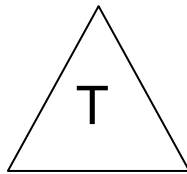
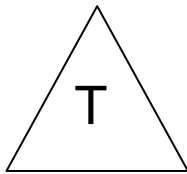
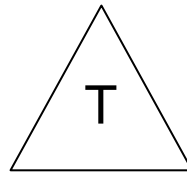
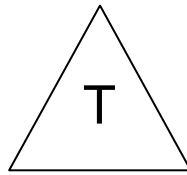
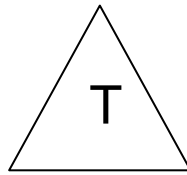
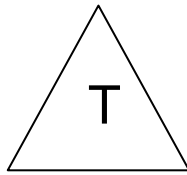
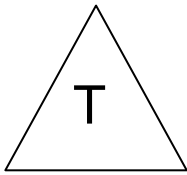
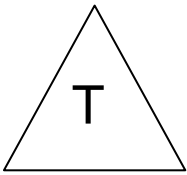
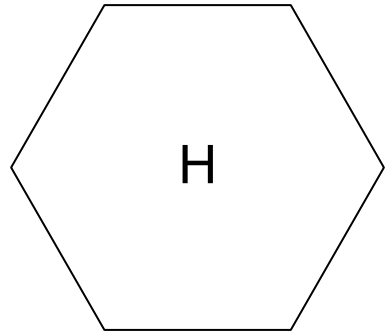
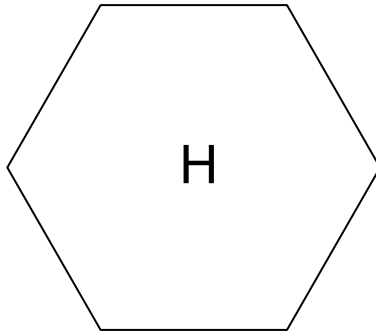
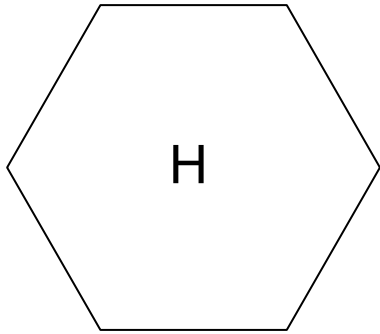



# BLM 4 Hundredths Grids

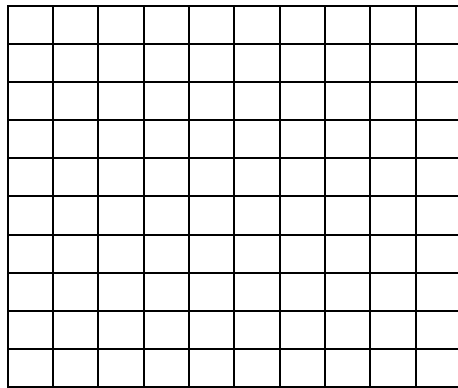
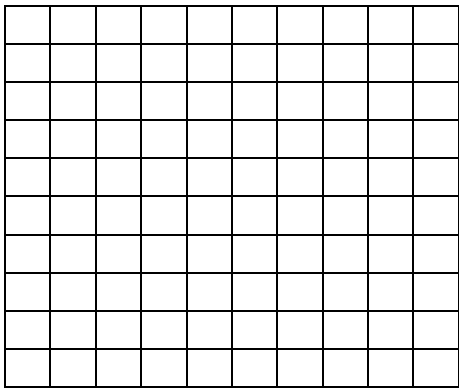
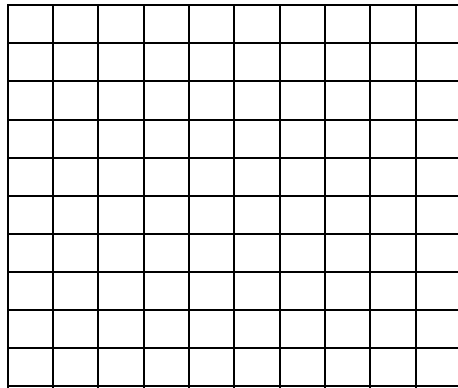
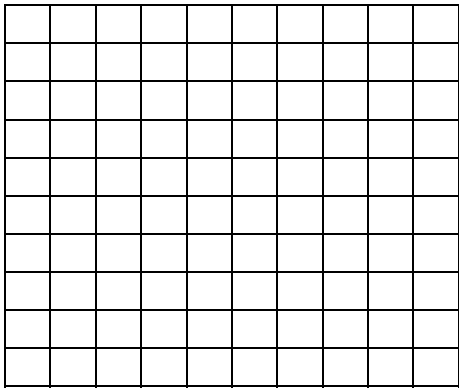
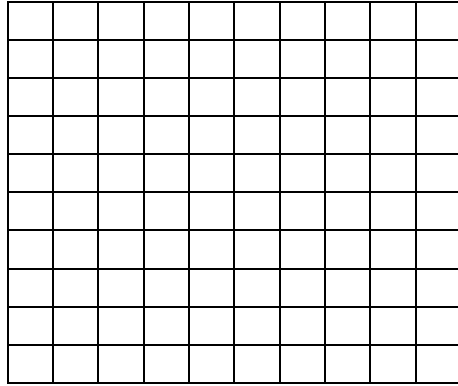
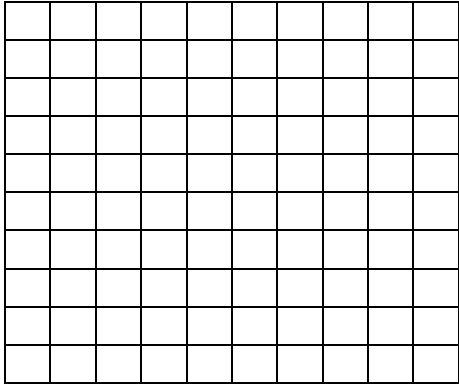
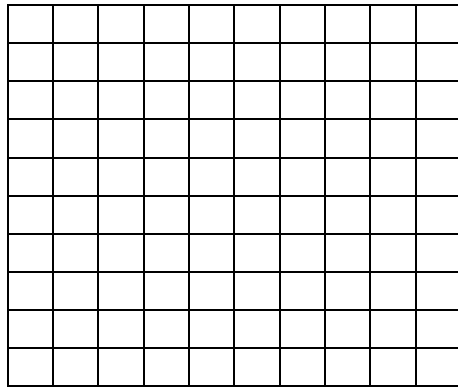
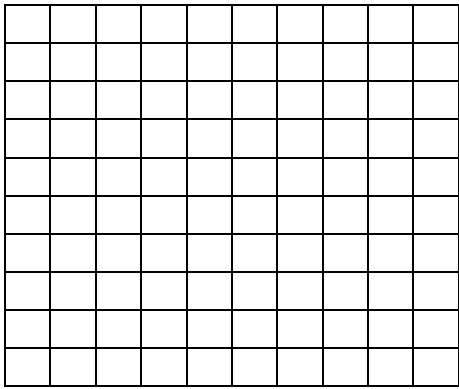

**BLM 5 Small Grid Paper**

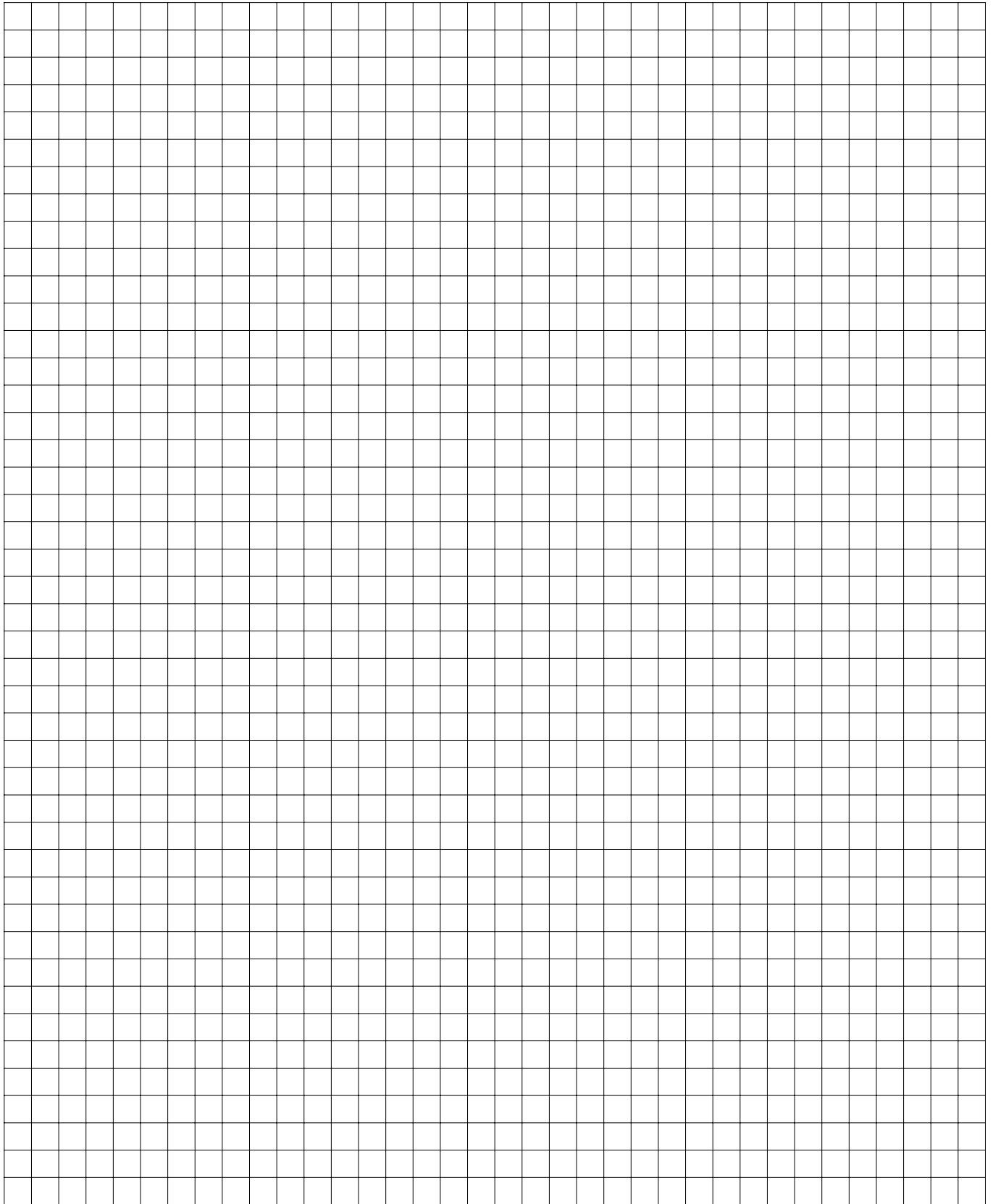

# UNIT 2 GEOMETRY

## UNIT 2 PLANNING CHART

	Outcomes or Purpose	Suggested Pacing	Materials	Suggested Assessment
Getting Started SB p. 27 TG p. 44	Review prerequisite concepts, skills, and terminology and pre-assessment	1 h	• Grid paper or Small Grid Paper (BLM)	All questions
<b>Chapter 1 2-D Geometry: Transformations</b>				
2.1.1 Rotations SB p. 29 TG p. 46	<b>6-E1 Rotations:</b> $\frac{1}{4}$ ( $90^\circ$ ), $\frac{1}{2}$ ( $180^\circ$ ), and $\frac{3}{4}$ turns • use a variety of turn centres: a vertex, on a side, and inside and outside the shape	1 h	• Grid paper or Small Grid Paper (BLM) • Rulers • Cardboard circle and trapezoids, and a pin (optional)	Q1, 2, 3, 5
2.1.2 Rotational Symmetry SB p. 34 TG p. 50	<b>6-E2 Rotational Symmetry Properties: squares and rectangles</b> • recognize, through concrete investigation, when a shape has rotational symmetry • discover, through concrete investigation, that a square has rotational symmetry of order 4 while a non-square rectangle has rotational symmetry of order 2 • relate rotational symmetry of squares and rectangles to other properties of squares and rectangles <b>6-E3 Rotational Symmetry: properties</b> • generalize for quadrilaterals and regular polygons • understand that, for a 2-D shape to have rotational symmetry, it must be turned around a point so that it exactly coincides with its original position at least once in less than a complete rotation • understand that the number of times it appears in the identical original position during one complete rotation is the order of turn symmetry • understand that if a shape has turn symmetry of order 1 (i.e., it needs to be rotated $360^\circ$ before it appears in the identical original position), then it does not have rotational symmetry	45 min	• Scissors • Grid paper or Small Grid Paper (BLM)	Q1, 2, 5, 7
2.1.3 Combining Transformations SB p. 37 TG p. 53	<b>6-E4 Combining Transformations: predict and confirm results</b> • predict and confirm the results of two transformations • understand that two congruent shapes on the same plane are images of one another under a translation, reflection, rotation, or any combination of these three transformations	1 h	• Large cardboard or paper copies of trapezoids A, B, C, and D • Grid paper or Small Grid paper (BLM) • Cardboard or paper trapezoids (optional)	Q1, 2, 5

## UNIT 2 PLANNING CHART [Continued]

	<b>Outcomes or Purpose</b>	<b>Suggested Pacing</b>	<b>Materials</b>	<b>Suggested Assessment</b>
GAME: Transformation Challenge (Optional) <b>SB p. 41</b> <b>TG p. 56</b>	Practise transformations in a game situation.	40 min	• Grid paper or Small Grid Paper (BLM) or Grid Paper (1 cm by 1 cm) (BLM)	N/A
<b>2.1.4 EXPLORE:</b> Tessellations (Essential) <b>SB p. 43</b> <b>TG p. 57</b>	<b>6-E5 Tessellations</b> • understand that, to tessellate, a shape must cover a surface with replications and without gaps or overlaps • describe, predict, and investigate a variety of shapes for tessellating properties	1 h	• Paper • Scissors • Tessellating Shapes (BLM) (optional)	Observe and Assess questions
CONNECTIONS: Escher-type Tessellations (Optional) <b>SB p. 44</b> <b>TG p. 60</b>	Make a connection between art and geometry.	1 h	• Grid paper or Small Grid Paper (BLM) • Rulers	N/A
<b>Chapter 2 2-D Geometry: Shapes and Properties</b>				
<b>2.2.1</b> Measuring Angles <b>SB p. 45</b> <b>TG p. 61</b>	<b>6-D8 Angles: estimate, measure, and draw</b> • use a protractor as a tool for measuring angles • estimate, measure, and draw angles from $0^\circ$ to $180^\circ$	1 h	• Protractors or Paper Protractors (BLM) • Large paper protractor (optional) • Field Angles (BLM) (optional)	Q1, 2, 5, 7
<b>2.2.2</b> Bisectors <b>SB p. 50</b> <b>TG p. 64</b>	<b>6-E6 Bisectors: angles and line segments</b> • recognize and describe angle bisectors • recognize and describe line segment bisectors, including perpendicular bisectors	1 h	• Paper squares • Rulers • Protractors or Paper Protractors (BLM) • Angle Bisectors (BLM) (optional)	Q1, 2, 3, 4
<b>2.2.3 EXPLORE:</b> Sorting Quadrilaterals (Essential) <b>SB p. 54</b> <b>TG p. 68</b>	<b>6-E7 Quadrilaterals: sort by attributes</b> • sort concretely by angles <b>6-E8 Diagonal Properties: generalize</b> • generalize about diagonals for a rhombus: the diagonals are perpendicular to each other and bisect each other, form four congruent right triangles, and are its two lines of reflective symmetry • generalize about diagonals for a parallelogram: the diagonals bisect each other and form two pairs of congruent triangles • generalize about diagonals for a kite: the diagonals are perpendicular and form two pairs of congruent right triangles; one of the diagonals is bisected, and the other diagonal is a line of reflective symmetry • understand that there are no special properties of the diagonals of a general trapezoid	1.5 h	• Sorting Quadrilaterals (BLM) (optional) • Scissors • Rulers • Protractors or Paper Protractors (BLM)	Observe and Assess questions
GAME: Go Fish (Optional) <b>SB p. 56</b> <b>TG p. 70</b>	Practise examining shapes for diagonal properties in a game situation.	30 min	• Go Fish Game Cards (BLM)	N/A

	Outcomes or Purpose	Suggested Pacing	Materials	Suggested Assessment
<b>Chapter 3 3-D Geometry</b>				
<b>2.3.1 EXPLORE:</b> Planes of Symmetry (Essential) <b>SB p. 57</b> <b>TG p. 71</b>	<b>6-E9 Planes of Symmetry: 3-D shapes</b> <ul style="list-style-type: none"> <li>• understand that some 3-D shapes have planes of reflective symmetry</li> <li>• investigate cubes, cones, cylinders, prisms, and pyramids for planes of symmetry</li> </ul>	1 h	<ul style="list-style-type: none"> <li>• Cubes</li> <li>• Sample Net of Cube (BLM) (optional)</li> </ul>	Observe and Assess questions
<b>2.3.2 EXPLORE:</b> Cross-sections (Essential) <b>SB p. 58</b> <b>TG p. 73</b>	<b>6-E10 Cross Sections: cones, cylinders, prisms, and pyramids</b> <ul style="list-style-type: none"> <li>• understand that a cross-section is the 2-D face produced when a straight cut is made through a 3-D shape</li> <li>• examine the properties of cross-sections concretely (e.g., cone: if a cut is made parallel to its base, the cross-section face produced is a circle; if a cut is made through its vertex and perpendicular to its base, the cross-section face is a triangle)</li> </ul>	1 h	<ul style="list-style-type: none"> <li>• Clay or dough</li> <li>• String or thin wire</li> <li>• Sample Net of Triangle-based Prism (BLM) (optional)</li> <li>• Sample Net of Rectangle-based Prism (BLM) (optional)</li> <li>• Sample Net of Square-based Pyramid (BLM) (optional)</li> <li>• Sample Net of Hexagon-based Prism (BLM) (optional)</li> </ul>	Observe and Assess questions
<b>2.3.3</b> Interpreting Orthographic Drawings <b>SB p. 59</b> <b>TG p. 75</b>	<b>6-E11 Orthographic Drawings: make and interpret</b> <ul style="list-style-type: none"> <li>• make and interpret structures built from cubes</li> <li>• understand that orthographic drawings are a set of 2-D views of a 3-D structure drawn by looking at it from the front, sides, top, and back</li> </ul>	1.25 h	<ul style="list-style-type: none"> <li>• Linking cubes</li> <li>• Sample Net of Cube (BLM)</li> </ul>	Q1, 2, 5
<b>2.3.4</b> Creating Orthographic Drawings <b>SB p. 63</b> <b>TG p. 78</b>	<b>6-E11 Orthographic Drawings: make and interpret</b> <ul style="list-style-type: none"> <li>• make and interpret structures built from cubes</li> <li>• understand that orthographic drawings are a set of 2-D views of a 3-D structure drawn by looking at it directly from the front, sides, top, and back</li> </ul>	1.25 h	<ul style="list-style-type: none"> <li>• Linking cubes</li> <li>• Sample Net of Cube (BLM) (optional)</li> <li>• Grid paper or Small Grid Paper (BLM)</li> </ul>	Q1, 3, 5
UNIT 2 Revision <b>SB p. 66</b> <b>TG p. 81</b>	Review the concepts and skills in the unit	2 h	<ul style="list-style-type: none"> <li>• Grid paper or Small Grid Paper (BLM)</li> <li>• Rulers</li> <li>• Protractors or Paper Protractors (BLM) (optional)</li> <li>• Sample Net of Square-based Pyramid (BLM) (optional)</li> <li>• Linking cubes (7 per student)</li> <li>• Sample Net of Cube (BLM) (optional)</li> </ul>	All questions

## UNIT 2 PLANNING CHART [Continued]

	Outcomes or Purpose	Suggested Pacing	Materials	Suggested Assessment
UNIT 2 Test TG p. 84	Assess the concepts and skills in the unit	1 h	<ul style="list-style-type: none"> <li>• Rulers</li> <li>• Protractors</li> <li>• Paper Protractors (BLM) (optional)</li> <li>• Linking cubes (7 per student)</li> <li>• Sample Net of Cube (BLM) (optional)</li> </ul>	All questions
UNIT 2 Assessment Interview TG p. 87	Assess concepts and skills in the unit	15 to 20 min	See <b>page 87</b>	All questions
UNIT 2 Performance Task TG p. 88	Assess concepts and skills in the unit	1 h	<ul style="list-style-type: none"> <li>• Grid paper (1 cm by 1 cm) (BLM)</li> <li>• Rulers</li> <li>• Scissors</li> </ul>	Rubric provided
UNIT 2 Blackline Masters TG p. 91	BLM 1 Tessellating Shapes (for <b>lesson 2.1.4</b> ) BLM 2 Paper Protractors BLM 3 Field Angles (for <b>lesson 2.2.1</b> ) BLM 4 Angle Bisectors (for <b>lesson 2.2.2</b> ) BLM 5 Sorting Quadrilaterals (for <b>lesson 2.2.3</b> ) BLM 6 Go Fish Game Cards BLM 7 Sample Net of Cube BLM 8 Sample Net of Right Triangle-based Prism BLM 9 Sample Net of Rectangle-based Prism BLM 10 Sample Net of Square-based Pyramid BLM 11 Sample Net of Regular Hexagon-based Prism BLM 12 Grid Paper (1 cm by 1 cm) Small Grid Paper on <b>page 38</b> in UNIT 1			

## Math Background

- This geometry unit revisits topics learned in previous years. It builds upon what students already know about transformations and properties of 2-D shapes and 3-D objects. The focus of the unit is on transformations, angles and bisectors, and representing 3-D objects in two dimensions.
- As students proceed through this unit they will use a variety of mathematical processes, including problem solving, communication, reasoning, representation, visualization, and making connections.

For example:

- Students use problem solving in **question 5** in **lesson 2.1.3**, where they decide how a shape was reflected using only the knowledge that the transformation could also be described by a translation, in **question 4** in **lesson 2.3.3**, where they build different cube structures that must have certain face views, and in **question 5** in **lesson 2.3.4**, where they build structures that share some, but not all, views.
- Students frequently use communication as they explain their thinking in answering questions such as **question 1** in **lesson 2.1.2**, where they explain why shapes have turn symmetry or not, and **questions 1 to 3** in **lesson 2.2.2**, where they explain how they knew the answers to questions about bisectors. In **question 5** in **lesson 2.3.3** they communicate when they offer suggestions for improving a sample student answer. In **question 6** in **lesson 2.3.3**, they discuss the need for multiple views.
- Students use reasoning in answering questions such as **question 1** in **lesson 2.1.1**, where they determine a centre of rotation, in **question 4 b)** in **lesson 2.1.3**, where they decide whether a combination of transformations will yield the same image if it is performed in the reverse order, and in **question 7** in **lesson 2.2.1**, where they decide what might have gone wrong when an acute angle measures  $120^\circ$ .
- Students consider representation in **lessons 2.3.3 and 2.3.4**, where cube structures are represented by orthographic drawings.
- Students use visualization skills throughout **chapter 1**, where they visualize the actions of transformations. They also use visualization skills in **chapter 3** as they picture planes of symmetry and the 2-D slices of 3-D shapes, and when they compare orthographic drawings to each other and to cube structures.

- Students make connections in **lesson 2.1.1**, where they link what they know about rotations with turn centre at a vertex to rotations with other turn centres. Students also make real-world connections in **question 3** in **lesson 2.1.2**, where they work with coin and wall designs, in **question 4** of **lesson 2.2.1**, where they look for examples of angles in the classroom, in **question 6** of **lesson 2.2.1**, where they look for angles in a photo of a field of rice paddies, and in **question 5** of **lesson 2.2.2**, where they examine a mosaic tile design for angle, line, and perpendicular bisectors.

## Rationale for Teaching Approach

- This unit is divided into 3 chapters.
- **Chapter 1** is about transformations.
- **Chapter 2** focuses on angle measurement and bisectors.
- **Chapter 3** examines properties of 3-D shapes and how to represent 3-D shapes in two dimensions using orthographic drawings.
- There are four **Explore** lessons in this unit. The first gives students a hands-on way to see how to use different shapes to make a tessellation, or tiling. The second lets students investigate the properties of the diagonals of various quadrilaterals. The third and fourth deal with 3-D shapes. Students investigate planes of symmetry and cross-sections. All of these topics are handled as explorations because this is the only effective way to learn these ideas.
- The **Connections** helps students see some connections between tessellations and visual art.
- There are two **Games** in this unit. The first game provides an opportunity to apply and practise work with combined transformations. The second game gives students practise identifying the properties of the diagonals of quadrilaterals. It highlights the different properties that the quadrilaterals can possess and gives students a chance to use the new bisector terminology they have learned.
- Throughout the unit, it is important to encourage students to use and develop their visualization skills.

## Getting Started

Curriculum Outcomes	Outcome relevance
<p><b>5</b> Triangles: explore equilateral, isosceles, scalene triangles, and right, obtuse, and acute triangles</p> <p><b>5</b> Diagonal Properties: squares and other rectangles</p> <p><b>5</b> Translations and Reflections using horizontal and vertical reflection lines: generalize and apply properties</p> <p><b>5</b> Parallelism and Perpendicularity: lines and line segments</p> <p><b>5</b> Rotations: quarter, half, and three-quarter rotations about the vertex of a shape</p> <p><b>4</b> Prisms, Pyramids, Cones, Cylinders</p>	<p>Students will find the work in the unit easier after they review the concepts and skills related to geometry they learned in Class V.</p>

Pacing	Materials	Prerequisites
1 h	<ul style="list-style-type: none"> <li>• Grid paper or Small Grid Paper (BLM)</li> </ul>	<ul style="list-style-type: none"> <li>• familiarity with the terms <i>right angle</i>, <i>perpendicular line segments</i>, <i>lines of symmetry</i>, <i>regular polygon</i>, and <i>congruent shapes</i></li> <li>• performing and describing transformations</li> <li>• familiarity with the names of 2-D shapes and 3-D shapes</li> <li>• understanding the properties of the diagonals of a square</li> <li>• classifying triangles by angle and by side length</li> </ul>

### Main Points to be Raised

#### Use What You Know

- Rotations and reflections transform shapes to congruent images.
- The diagonals of a square
  - are lines of symmetry,
  - are perpendicular, and
  - meet at their centre points.

#### Skills You Will Need

- A quadrilateral is named by its number of congruent and parallel sides.
- A regular polygon has all sides congruent and all angles congruent.
- A translation can be described by a rule that says how far left or right and how far up or down a shape is moved.
- A triangle can be named for its angles:
  - A right triangle has one right angle and two acute angles.
  - An acute triangle has three acute angles.
  - An obtuse triangle has one obtuse angle and two acute angles.
- A triangle can be named for its side lengths:
  - An equilateral triangle has three congruent sides.
  - An isosceles triangle has two congruent sides.
  - A scalene triangle has no congruent sides.
- A 3-D shape can be named for its faces.

### Use What You Know — Introducing the Unit

- Students can work in pairs or small groups.
- Before students begin the work, review the terms *right angles*, *perpendicular line segments*, *lines of symmetry* to make sure they can interpret **part B** successfully. Refer students to the glossary at the back of the student text. Distribute one sheet of grid paper for each pair or small group. Ask students to work through **parts A to C**.

While you observe students at work, you might ask questions such as the following:

- *How did you reflect the triangle?* (The vertical side of the triangle is the reflection line, so it is part of the image. I drew the image of the left vertex the same distance away from the reflection line on the other side of the line. Then I joined that vertex to the vertical side.)
- *How did you rotate the triangle?* (I know that a  $\frac{1}{4}$  turn makes a right angle. I used the right angles of the grid and made sure the image point was the same distance from the original point. Then I connected the image vertices.)
- *What other rotation would give the same image?* (A  $\frac{3}{4}$  turn ccw is the same as a  $\frac{1}{4}$  turn cw.)



- How did you identify right angles in your design? (I used the grid for some — vertical and horizontal lines of a grid meet at right angles and for others I knew that the diagonals of a square meet at a right angle at the vertex.)

### Skills You Will Need

- Students can work individually.
- To ensure students have the required skills for this unit, assign these questions.
- Before students begin the work, review the terms *rhombus*, *trapezoid*, *parallelogram*, *kite*, *regular polygon*, *translation*, *prism*, and *pyramid* to make sure students can interpret **questions 1, 2, 3, and 7** successfully. Also review the terms *acute triangle*, *obtuse triangle*, *right triangle*, *scalene triangle*, *isosceles triangle*, and *right triangle* to make sure students have success with **questions 4 and 5**. Refer students to the glossary at the back of the student text.

### Answers

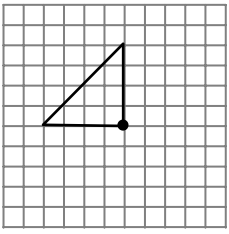
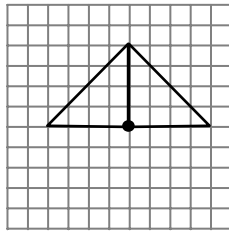
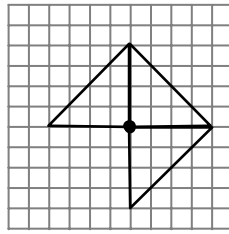
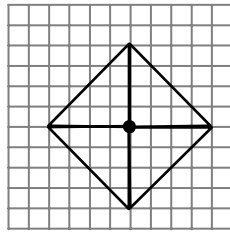
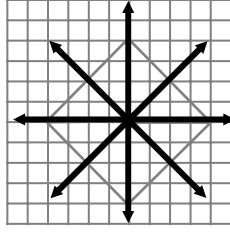
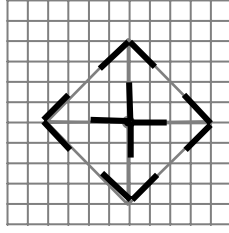
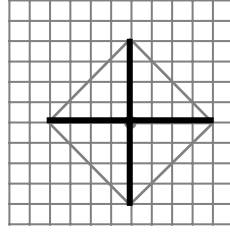
<p><b>A. i)</b></p> 	<p><b>ii)</b></p> 	<p><b>iii)</b></p> 	<p><b>iv)</b></p> 
<p><b>B.</b> Students can make a sketch to show their answers. Or, then can mark their answers on the grid paper using different colours, if possible.</p>		<p><b>iii)</b></p> 	
<p><b>i)</b></p> 		<p><b>ii)</b></p> 	
<p><b>C.</b> The diagonals of a square meet at right angles at their centre points. I know this because the diagonals are on the perpendicular grid lines and I can count the squares to see that they intersect in the middle.</p>			
<p><b>1. a) B      b) C      c) D or B</b>  <b>d) A or B</b> (A rhombus has congruent adjacent sides so it may also be classed as a kite.)</p>		<p><b>4. a) Right      b) Acute      c) Obtuse</b></p>	
<p><b>2. A, B, and C;</b> [The sides are all the same length and the angles are the same size.]</p>		<p><b>5. a) Scalene      b) Equilateral      c) Isosceles</b></p>	
<p><b>3. 3 units left, 5 units up</b></p>		<p><b>6. A and E are congruent; D, B, and F are congruent.</b></p>	
		<p><b>7. a) Cylinder</b>  <b>b) Sample response:</b> Pentagon-based pyramid  <b>c) Sample response:</b> Octagon-based prism</p>	

### Supporting Students

#### Struggling students

- If students are struggling with the transformations in **part A** or in **question 3**, you might have them use a cut-out copy of the triangle to flip, turn, or translate. They can trace the paper triangle to show the transformation.
- Some students focus on classifying triangles only by side length relationships or only by angle relationships; they do not use both. You may need to revisit the idea that any triangle can be sorted in several ways.

#### Enrichment

- For **part A**, you might challenge students to predict what would happen if they performed the same transformations starting with a right scalene triangle rather than with a right isosceles triangle. (They would create a rhombus with the same properties for the diagonals.)

# Chapter 1 2-D Geometry: Transformations

## 2.1.1 Rotations

Curriculum Outcomes	Outcome relevance
<p><b>6-E1 Rotations:</b> <math>\frac{1}{4}</math> (<math>90^\circ</math>), <math>\frac{1}{2}</math> (<math>180^\circ</math>), and <math>\frac{3}{4}</math> turns</p> <ul style="list-style-type: none"> <li>use a variety of turn centres: a vertex, on a side, and inside and outside the shape</li> </ul>	<ul style="list-style-type: none"> <li>Transformations, including rotations, are abundant in the world around us. This makes their study both relevant and important.</li> <li>This lesson builds on what students have learned about rotations in previous years. Now the turn centre can be located anywhere, and not just at a vertex of a shape.</li> </ul>

Pacing	Materials	Prerequisites
1 h	<ul style="list-style-type: none"> <li>Grid paper or Small Grid Paper (BLM)</li> <li>Rulers</li> <li>Cardboard circle and trapezoids, and a pin (optional)</li> </ul>	<ul style="list-style-type: none"> <li>familiarity with translations, reflections, and rotations with the turn centre located at a vertex</li> </ul>

### Main Points to be Raised

- A rotation is a transformation that turns a shape around a fixed point called the turn centre.
- Every rotation can be described by its turn centre, size (angle or fraction of a full turn), and direction (clockwise or counterclockwise).
- The turn centre can be located anywhere: at a vertex, inside the shape, outside the shape, or on the side of a shape.
- The properties of a rotation are the same regardless of where the turn centre is located.
  - The image of a rotation is congruent to the original shape.
  - Any point and its image point are the same distance to the turn centre.
- A  $\frac{1}{4}$  turn and a  $\frac{3}{4}$  turn both create a right angle when a point and its image are connected to the turn centre.
- A  $\frac{1}{2}$  turn creates a straight line segment.

### Try This — Introducing the Lesson

A. Allow students to try this alone or with a partner. Provide grid paper so students can investigate the effect of different types of transformations. Observe while students work. As they work, encourage them to think about the orientation of the arrow. You might ask questions such as the following:

- Which direction would the image point if the arrow were translated? (It would point the same way as Shape 1.)
- What would the image of Shape 1 look like if you reflected it in a horizontal line? (It would point the same direction, just like a translation image.)
- What would it look like if the reflection line were vertical? (It would point to the right instead of to the left.)
- How could you make the arrow point down? (I could turn it.)

### The Exposition — Presenting the Main Ideas

- Briefly review rotations with the class. You might ask questions such as:
  - What three things must you know before you can rotate a shape? (The turn centre, the direction of the turn, and the size of the turn.)
  - How do we describe the direction of a turn? (cw or ccw)
  - How do we describe the size of a turn? (We describe it as a fraction of a whole turn.)
- Explain to the class that this lesson will extend their knowledge of rotations to situations where the turn centre is not at a vertex. Emphasize that the properties of a rotation stay the same no matter where the turn centre is located. (A rotation of any size is possible and the corresponding sizes for cw and ccw will always add to one whole.)

- If possible, model the information in the exposition using a large cardboard circle marked in quarters, two pairs of congruent trapezoids, and a pin to join the trapezoid pairs at the turn centre. One pair of trapezoids should have long cardboard strips attached to the long side to extend the length of the circle radius. Use these when the turn centre is outside the shape (see diagram at the far right).

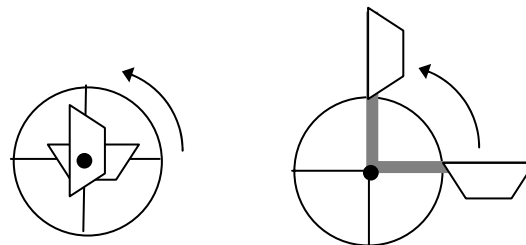

Alternatively, you can draw the circle, the original trapezoid, and its image on the board. In this case you should model the action by hand movement and further indicate it with arrows.

- As you work through the exposition, emphasize that the distance from a point to the turn centre remains constant during the rotation.

## Revisiting the Try This

**B.** This question allows students to connect what was done in **part A** to the exposition. In this case, students can draw the arrows on grid paper and locate the turn centre through trial and error. You may need to remind them that the distance from a point to the turn centre is the same as the distance from its image to the turn centre.

## Using the Examples

- Have students work in pairs. One student should become an expert on **example 1** and the other should become an expert on **example 2**. They must each explain their example to the other student. For **example 1**, make sure students realize that, although the point marked N is on both the original shape and the image, the image of point N is not at N; it is actually the image of point O that moved to the original position of point N.
- Partners should then go through **example 3** together. Point out that if they were answering the question, they would be expected to write down the work, much like what they see on the left (under **Solution**), but they would be thinking what they read on the right (under **Thinking**). You might ask students how they would have performed the rotation if the pentagon had been on grid paper.

## Practising and Applying

### Teaching points and tips

**Q 1:** For this question you might encourage students to focus on one vertex and the corresponding image point when they decide upon an answer. Remind them that a point and its image point are the same distance from the turn centre and that  $\frac{1}{4}$  or  $\frac{3}{4}$  turns create right angles while  $\frac{1}{2}$  turns create straight line segments.

**Q 2:** Students who need guidance can follow **example 2** for this question.

**Q 3:** Refer students to **example 3** for help with this question.

**Q 4:** There are three possible turn centres that fall on the grid inside the shape for **part c**). Be sure to read student answers carefully.

**Q 5:** Use this last question as a closure question. It is a way to highlight the important ideas students have learned in the lesson.

### Common errors

- Some students will have difficulty identifying the turn centre in **question 1**. You might encourage students first to decide the size of the turn. Once they have determined that it is a  $\frac{1}{4}$  or  $\frac{3}{4}$  turn, they can use trial and error to determine the turn centre. Remind them there should be a right angle between a vertex, the turn centre, and the image point

**Suggested assessment questions from Practising and Applying**

<b>Question 1</b>	to see if students can locate a turn centre and describe a rotation given a shape and its image
<b>Question 2</b>	to see if students can rotate a shape a $\frac{1}{4}$ or $\frac{3}{4}$ turn
<b>Question 3</b>	to see if students rotate a shape a $\frac{1}{2}$ turn
<b>Question 5</b>	to see if students can explain the similarities and differences of rotations with different turn centres

**Answers**

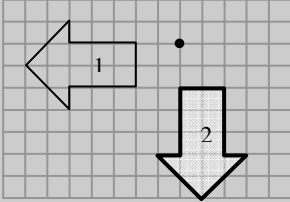
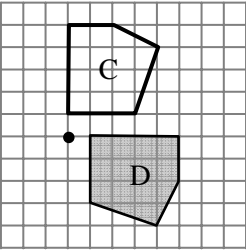
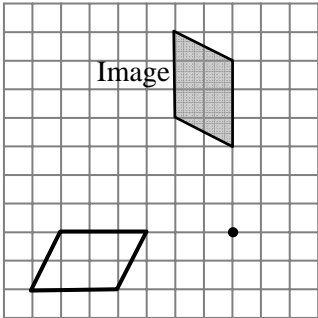
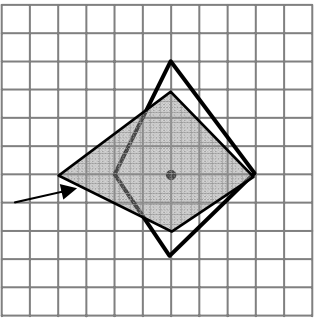
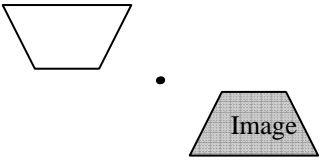
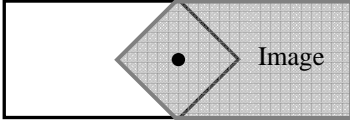
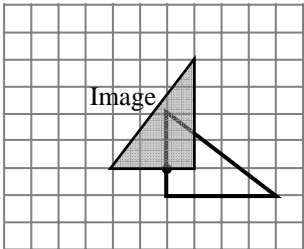
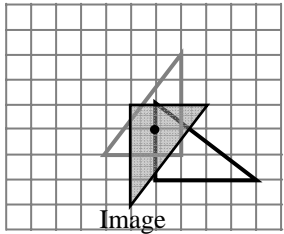
<p><b>A. Sample response:</b></p> <ul style="list-style-type: none"> <li>• If it were a translation or a reflection in a horizontal line, the arrow would be pointing left.</li> <li>• If it were a reflection in a vertical line, the arrow would be pointing right.</li> <li>• You have to turn the arrow to make it point downward.</li> </ul>	<p><b>B. i)</b></p>  <p><i>Sample response:</i> Each point is the same distance to the turn centre. I found it by trial and error.</p> <p><b>ii)</b> It is a <math>\frac{1}{4}</math> turn ccw around the turn centre or a <math>\frac{3}{4}</math> turn cw around the turn centre.</p>
<p><b>1. a) and b)</b></p>  <p><b>c)</b> A <math>\frac{1}{4}</math> turn cw around the turn centre or a <math>\frac{3}{4}</math> turn ccw around the turn centre.</p> <p><b>2. a)</b></p>  <p><b>b)</b></p> 	<p><b>3. a)</b></p>  <p><b>b)</b></p>  <p><b>4 a), b)</b></p>  <p><b>c) Sample response:</b></p>  <p><b>5. Sample response:</b> Similar: Each image vertex is always the same distance to the turn centre as the original vertex. Different: When the turn centre is inside the shape, the image and the original shape overlap. When it is outside the shape, they might not overlap.</p>

## Supporting Students

### *Struggling students*

- If students are struggling to rotate the shapes in **questions 2, 3, and 4**, you might encourage them to treat their work as predictions. They can trace the shapes, cut them out, then rotate them to check their answers. Stress that the distance from any point on the cut-out shape to the turn centre is the same before and after the turn.

### *Enrichment*

- For **question 4**, you might challenge students to describe a single rotation that transforms the original triangle to the image from **part c**). The answer will involve a  $\frac{1}{4}$  turn cw or a  $\frac{3}{4}$  turn ccw. The turn centre will depend on the turn centre chosen for **part c**). The turn centre for the sample response given in the answers is shown to the right.

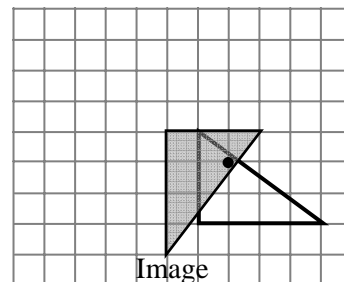

## 2.1.2 Rotational Symmetry

Curriculum Outcomes	Outcome relevance
<p><b>6-E2 Rotational Symmetry Properties: squares and rectangles</b></p> <ul style="list-style-type: none"> <li>recognize, through concrete investigation, when a shape has rotational symmetry</li> <li>discover, through concrete investigation, that a square has rotational symmetry of order 4 while a non-square rectangle has rotational symmetry of order 2</li> <li>relate rotational symmetry of squares and rectangles to other properties of squares and rectangles</li> </ul> <p><b>6-E3 Rotational Symmetry: properties</b></p> <ul style="list-style-type: none"> <li>generalize for quadrilaterals and regular polygons</li> <li>understand that, for a 2-D shape to have rotational symmetry, it must be turned around a point so that it exactly coincides with its original position at least once in less than a complete rotation</li> <li>understand that the number of times it appears in the identical original position during one complete rotation is the order of turn symmetry</li> <li>understand that if a shape has turn symmetry of order 1 (i.e., it needs to be rotated <math>360^\circ</math> before it appears in the identical original position), then it does not have rotational symmetry</li> </ul>	<p>Rotational symmetry is basic to many real-world situations. For example, one of the reasons we use circular lids is that they fit back onto containers in more ways than other shapes do — this is because of rotational symmetry.</p>

Pacing	Materials	Prerequisites
45 min	<ul style="list-style-type: none"> <li>Scissors</li> <li>Grid paper or Small Grid Paper (BLM)</li> </ul>	<ul style="list-style-type: none"> <li>familiarity with rotations and the properties of regular polygons</li> </ul>

### Main Points to be Raised

- Turn symmetry is a kind of symmetry that is based on rotations.
- A shape has turn symmetry if it looks the same when it is rotated less than one full turn around a turn centre.
- The order of turn symmetry is the number of times a shape looks the same during one full turn.
- A shape with no turn symmetry has turn symmetry of order 1.

### Try This — Introducing the Lesson

**A.** Allow students to try this alone or with a partner. While you observe students at work, you might ask questions such as the following:

- How do you know when the shape has been rotated one full turn? (The arrows line up again.)*
- How would you describe the location of the turn centre? (It is in the centre of the shape.)*
- Could you have predicted that T would need a full turn before it lined up with the original shape? (Yes; One side is longer than all the others. It can only line up with itself.)*

If students incorrectly count the number of times the shapes line up, be sure they are not including the original position; they should begin rotating the shape before they start to count.

### The Exposition — Presenting the Main Ideas

• Explain to the class that symmetry is based on the notion that a shape can look the same after certain transformations in ways that other shapes do not.

For example, a square looks the same when you reflect it using a horizontal line through its centre, whereas an irregular shape does not look the same when you reflect it through its centre.

• A shape can be symmetric in different ways. In this lesson students will learn about a type of symmetry that is based on rotations.

- Draw students' attention to the exposition on **page 34** of the student text. Read through the first section together. To make sure they understand the concepts, ask question such as:
  - *How can you tell the triangle has been rotated?* (You can tell by the letters at the vertices.)
  - *Would you be able to tell the triangle had been rotated if the letters were not there?* (No. The triangle would look identical in each position.)
- Discuss different examples of rotational symmetry in everyday life (wheels or tires on vehicles and bicycles, designs in textiles, the pattern on a checkerboard, dominoes with double numbers).
- Work through the rest of the exposition with the class. You might use the equilateral triangle shown earlier in the exposition as an example of a regular polygon with order of turn symmetry equal to the number of sides. Allow ample time for students to ask any questions they have.

### Revisiting the Try This

**B.** This question allows students to make a formal connection between what was done in **part A** and the main ideas presented in the exposition. It gives students some practice stating that shapes with no rotational symmetry have rotational symmetry of order 1.

### Using the Examples

- Present the problems in **example 1** to the students. Ask the students to solve them and explain their thinking. Then students can compare their work to what is shown in the student text. Suggest that students also read through **example 2**.

### Practising and Applying

#### Teaching points and tips

**Q 1 and 2:** Students can check their predictions by tracing the shapes and rotating them using a pencil point for the turn centre, as in the **Try This**. (You might suggest that they mark an arrow in the same position on the original shape and on the copy so they can easily tell when the copy has been rotated one full turn.) For **parts a), c), and d)**, recognizing that the shapes are regular polygons is an acceptable explanation.

**Q 3:** This question provides an interesting real-world link. Some students may not recognize the turn symmetry in these elaborate designs. Encourage them

to think about the turn symmetry of the polygon that contains the design, as in **example 2**.

**Q 4:** This question provides a further real-world link. It may be helpful to create, or have students create, a list or a visual display of real-world examples to post in the classroom. Items can be added as students encounter more examples in their everyday lives.

**Q 7:** Students will synthesize the new ideas they have encountered as they communicate about the turn symmetry in different types of shapes.

#### Common errors

- Some students may identify turn symmetry incorrectly in **question 1 b) and g)**. They may confuse turn symmetry with lines of symmetry. It may help to discuss the different types of transformations they have studied. Explain that lines of symmetry relate to reflections, while turn symmetry relates to rotations.
- Many students will say that the order of turn symmetry is 0 for shapes without turn symmetry in **question 2**. You should reinforce the definition of order of turn symmetry.

For example, create a classroom display that shows the definition and an example to illustrate, or have students make a similar entry in their notebooks. Stress that every shape looks the same when it has been rotated one full turn.

#### Suggested assessment questions from Practising and Applying

<b>Question 1</b>	to see if students can recognize turn symmetry in a shape
<b>Question 2</b>	to see if students can apply the definition of order of turn symmetry
<b>Question 5</b>	to see if students recognize the effect on turn symmetry when a shape is modified
<b>Question 7</b>	to see if students can explain how turn symmetry relates to regular polygons

## Answers

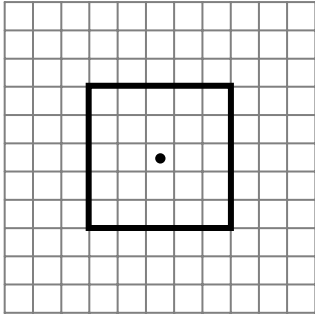
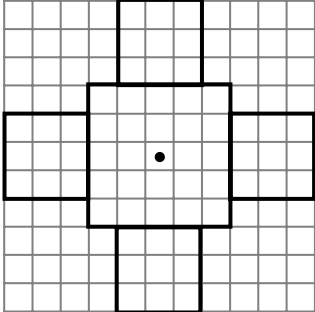
<p><b>A.</b> S 4    T 1    R 2</p>	<p><b>B.</b> S has turn symmetry of order 4; T does not have turn symmetry (so the order is 1); R has turn symmetry of order 2.</p>
<p><b>1. Sample response:</b>  <b>a)</b> Yes; [because it is a regular polygon.]  <b>b)</b> No; [because it has one long side that can only line up with itself.]  <b>c)</b> Yes; [because it is a regular polygon.]  <b>d)</b> Yes; [because it is a regular polygon.]  <b>e)</b> Yes; [because each of the star points is the same size.]  <b>f)</b> Yes; [because each of the arrows on the square is the same size.]  <b>g)</b> No; [because no matter where a turn centre is placed, the longer sides will not line up again until it has made one full turn.]  <b>h)</b> Yes; [because both the triangles are the same size.]</p> <p><b>2. a)</b> 8    <b>b)</b> 1    <b>c)</b> 4    <b>d)</b> 5  <b>e)</b> 5    <b>f)</b> 4    <b>g)</b> 1    <b>h)</b> 2</p> <p><b>3. a)</b> The design in the middle of the coin has turn symmetry of order 4; the turn centre is in the middle of the design.  <b>b)</b> Turn symmetry of order 2; the turn centre is in the middle of the centre flower.</p> <p><b>4. Sample response:</b></p> <ul style="list-style-type: none"> <li>• The rectangular chalkboard has turn symmetry of order 2.</li> <li>• The design on the window frame has turn symmetry of order 4.</li> <li>• The square desktop has turn symmetry of order 4.</li> </ul>	<p><b>5. a)</b> Turn symmetry of order 4, turn centre is marked.</p>  <p><b>b)</b> Turn symmetry of order 4, turn centre is marked.</p>  <p><b>c)</b> No; [<i>Sample response:</i> No matter which three squares I include, there is one side without an added square. The shape will have to rotate one full turn before the design lines up.]</p> <p><b>6. Shape A;</b> [<i>Sample response:</i> Shape B could not have turn symmetry because there is only one long side.]</p> <p><b>[7. Sample response:</b> The order of turn symmetry will automatically be the same as the number of sides for a regular polygon. For other shapes, you might have to test by turning.]</p>

## Supporting Students

### Struggling students

• Students who are struggling with the concepts in this lesson may find it helpful to keep a “Turn Symmetry Journal”. Have them use one page for each order of turn symmetry they encounter. On each page, they can trace examples from the **Practising and Applying** exercises, the **Try This**, the exposition, and the examples. Encourage them to continue to add to their journal as they move on to new lessons.

### Enrichment

- For **question 5 c)**, you might ask students to describe the turn symmetry if only two new squares had been added. The answer calls for reasoning skills, as it depends upon the placement of the two squares.
- Some students will enjoy creating their own designs similar to the design in **question 5**. Challenge them to create several designs, each with turn symmetry of a different order.



## 2.1.3 Combining Transformations

Curriculum Outcomes	Outcome relevance
<b>6-E4 Combining Transformations: predict and confirm results</b> <ul style="list-style-type: none"> <li>• predict and confirm the results of two transformations</li> <li>• understand that two congruent shapes on the same plane are images of one another under a translation, reflection, rotation, or any combination of these three transformations</li> </ul>	This outcome makes students aware of the close connection between congruence and transformations. Two shapes are only congruent if a combination of reflections, translations, and rotations allows one shape to be transformed to the other.

Pacing	Materials	Prerequisites
1 h	<ul style="list-style-type: none"> <li>• Large cardboard or paper copies of trapezoids A, B, C, and D</li> <li>• Grid paper or Small Grid paper (BLM)</li> <li>• Cardboard or paper trapezoids (optional)</li> </ul>	<ul style="list-style-type: none"> <li>• familiarity with transformations</li> </ul>

### Main Points to be Raised

- A shape can always be transformed to a congruent shape. More than one transformation may be required.
- Some combinations of transformations result in the same image as a single transformation.

### Try This — Introducing the Lesson

A. Allow students to try this alone or with a partner. While you observe students at work, you might ask questions such as the following:

- *How do you know that Triangle 1 has been reflected onto Triangle 2?* (The long side of Triangle 1 is vertical and on the left, while the long side of Triangle 2 is vertical and on the right.)
- *How do you know that Triangle 2 has been rotated onto Triangle 3?* (The long side of triangle 2 is vertical, while the long side of triangle 3 is horizontal. I can picture the rotation.)
- *How do you know that a single transformation will not take Triangle 1 to Triangle 3?* (If I translate or reflect Triangle 1 in a horizontal or vertical line, the long side will stay vertical. If I rotate Triangle 1 so that the long side is horizontal, it will be on top rather than on the bottom like it is in Triangle 3.)

### The Exposition — Presenting the Main Ideas

- Discuss transformations with the class. Ask them what they know about the image of any transformation (it is congruent to the original shape). Explain that in this lesson they will look at things the other way around: every congruent shape is the image of some transformation or combination of transformations.
- Read through the exposition together as a class. If possible, use cardboard or paper trapezoids on a tabletop to model the transformations in the first section.

After you have finished discussing the second section (on **page 38** of the student text), revisit the first section. Invite volunteers to use different combinations of transformations that have the same image as those shown.

For example, A can be transformed onto B by translating in a different way and then reflecting:

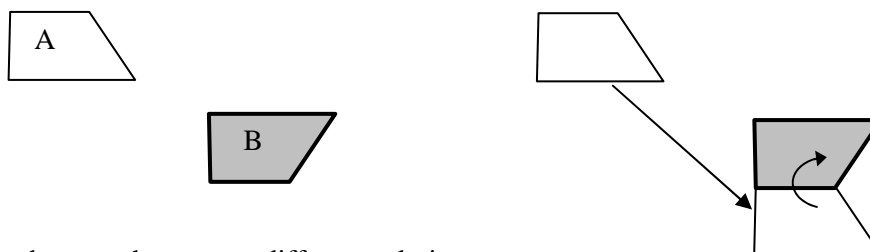

Allow time for students to show many different solutions.

## Revisiting the Try This

**B.** This question allows students to connect what was done in **part A** to the exposition. This reinforces the idea that different combinations of transformations can result in the same image.

### Using the Examples

- Assign students to pairs. Have one student in each pair become the expert on **example 1** and the other become the expert on **example 2**. Each expert should not only follow the given explanation, but actually perform it. Each should then explain his or her example to the other student. In **example 2, solution 2**, students should observe that the two grey lines showing the distance from one vertex to the turn centre and from its image to the turn centre are congruent and form a right angle or  $\frac{1}{4}$  turn..

### Practising and Applying

#### Teaching points and tips

**Q 1:** Many correct solutions are possible for each part of this question. Be sure to read student responses carefully.

**Q 2:** Shapes C and E can be included in correct solutions to **parts a) and b)**. Because of this, you might encourage students to consider all the shapes when they answer each part of the question. It may also be helpful to refer students back to the exposition on **page 38** of the student text.

**Q 4:** This question may challenge students who do not have strong visualization skills. You might suggest that they attempt the predictions in **parts a) and b)** to help them strengthen their skills.

**Q 5:** Some students may need to be reminded that they can use specific examples to help formulate or explain their answers.

#### Common errors

- Many students will focus on the outline of the shape in **question 2** and will answer incorrectly as a result. You might gently suggest that the position of the grey square is important. This is particularly true for shapes B and E because their orientation may make it more difficult to visualize the transformations.

#### Suggested assessment questions from Practising and Applying

<b>Question 1</b>	to see if students can recognize and describe multiple transformations
<b>Question 2</b>	to see if students can recognize and describe a single transformation
<b>Question 5</b>	to see if students can apply what they have learned about transformations to solve a problem

### Answers

**A. Sample responses:**

**i)** Triangle 1 can be reflected across a vertical line to Triangle 2.

**ii)** Triangle 2 can be rotated a  $\frac{1}{4}$  turn cw around the point shown to Triangle 3.

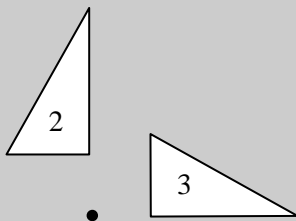

**iii)** Triangle 1 can be transformed to Triangle 3 by first reflecting it to Triangle 2, and then rotating the image.

**B.** Triangle 1 could be translated, then rotated, then reflected, as shown.

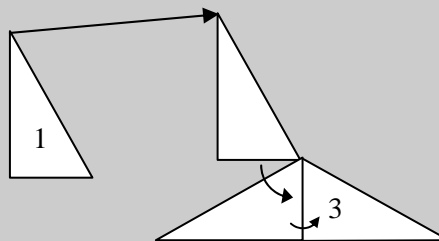

**1. Sample responses:**

a) Translate right to line up with the grey shape then reflect across a horizontal line between the shapes.

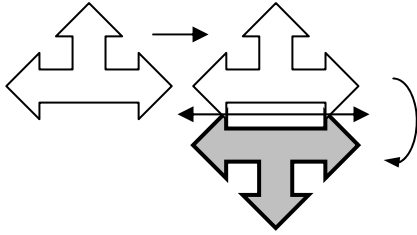

b) Rotate a  $\frac{1}{4}$  turn cw around the vertex where the shapes touch, then reflect across the left side.

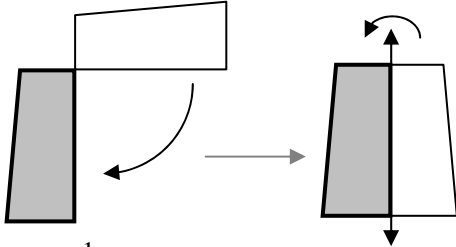

c) Rotate a  $\frac{1}{2}$  turn around a point in the centre, then translate it right.

**2. a)** C is a translation image of A. E is a rotation image of A.

**b) Sample response:**

- Reflect A across a horizontal line and then translate it to shape B.
- Reflect A across a vertical line and then translate it to shape D.
- Translate A so that the grey square touches E and

then rotate it a  $\frac{1}{2}$  turn around the point where they touch.

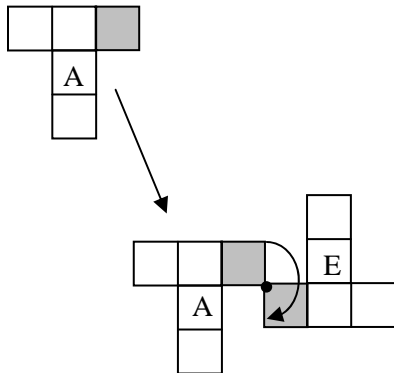

**3. Sample responses:**

a) Rotate A a  $\frac{1}{4}$  turn ccw around a point below

Shape B and to the left of Shape A.

b) Translate Shape A so the lower left vertex of Shape A touches the lower right vertex of Shape B,

then rotate Shape A a  $\frac{1}{4}$  turn cw around that vertex.

c)

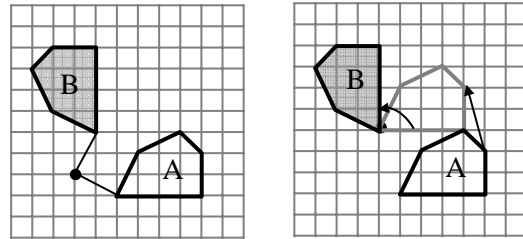

**4. a)** The final image will be to the left of the line. It will be pointing in the opposite direction with its right vertex on the line. [When you translate it 2 units left and three units down, its left vertex will be on the line. When you reflect it across the line, the shape will flip horizontally but that vertex will not move.]

**b)** No; [If you first reflect Shape A, the closest point to the line will be 2 units away from the line. Then, when you move it 2 units left and down 3 units, it will move farther from the line.]

c)

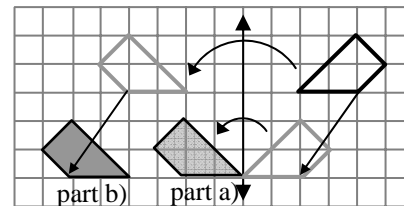

**5. Sample response:**

Tshering might have done two reflections. [If you reflect once, a shape points in the opposite direction. If you reflect again in a line that runs in the same direction as the first reflection line, the image flips back the way it originally pointed, just like a translation image.]

**Supporting Students**

*Struggling students*

- Students who have difficulty performing transformations will find this lesson challenging. It may be helpful to have them work with a partner to answer these questions. It may also help to use a cut-out copy of the shapes to investigate the transformations in **questions 1, 3, and 4**. If students are uncomfortable predicting, allow them to perform the transformations.

*Enrichment*

- For **question 1**, you might challenge students to find several different answers for each part.

## GAME: Transformation Challenge

- This optional game allows students to practise describing transformations and combinations of transformations in different ways. It also builds visualization and communication skills.
- Here is a variation on the game:
  - Player A places both shapes on the grid paper.
  - Player B describes a transformation or combination of transformations that takes one shape to the other to earn 1 point.
  - Player A wins 2 points if he or she can describe a transformation or combination of transformations that uses fewer transformations than those put forward by Player B.
  - The player with the higher score at the end of 10 rounds wins.
  - Players take turns playing the roles of Player A and Player B.
- The game and its variation can be played in teams if there are more than two players. In this case, encourage group members to discuss their answers before revealing their descriptions to the other team.

## 2.1.4 EXPLORE: Tessellations

Curriculum Outcomes	Outcome Relevance
<b>6-E5 Tessellations</b> <ul style="list-style-type: none"> <li>• understand that, to tessellate, a shape must cover a surface with replications and without gaps or overlaps</li> <li>• describe, predict, and investigate a variety of shapes for tessellating properties</li> </ul>	This essential exploration provides a hands-on way to discover which shapes tessellate. The importance of tessellations is highlighted by their abundance in the real world. They can be found in human-made objects such as artwork, floor tiles, decorative tile mosaics, textile patterns, and needlework. Tessellations can also be found in nature in items such as honeycombs and the surface of insect eyes when the view is greatly magnified.

Pacing	Materials	Prerequisites
1 h	<ul style="list-style-type: none"> <li>• Paper</li> <li>• Scissors</li> <li>• Tessellating Shapes (BLM) (optional)</li> </ul>	<ul style="list-style-type: none"> <li>• familiarity with transformations and polygons</li> </ul>

### Exploration

- Work through the introduction (in white) with the students. After reading the definition of a tessellation together, discuss the examples shown. Make sure that students understand how the tessellation can be extended in every direction. Also make sure they understand that, although the arrangement of octagons can also be extended in every direction, it is not a tessellation because of the gaps. Students need not worry about what happens at the perimeter of the tessellation; they should examine only the centre of each tessellation. For example, square tiles might have to be cut to fit into a particular rectangle, but the squares still tessellate because the bulk of the shape is covered completely by the squares without gaps or overlapping.

- Briefly discuss with the students the names and abbreviations of the shapes:

RH = regular hexagon

RP = regular pentagon

IT = isosceles trapezoid (a trapezoid that has a line of symmetry)

H1 = hexagon 1

H2 = hexagon 2

Tra = trapezoid

O = octagon

Q = quadrilateral

Tri = triangle

Encourage students to visualize how the shapes might fit together. Then ask them to write down their predictions for **part A**.

- Have students work in pairs or small groups. Distribute scissors and a copy of Tessellating Shapes (BLM) to each group of students to complete **parts B and C** (or have students trace the shapes in the text). Make sure every shape is attempted by at least one group.

While you observe students at work, you might ask questions such as the following:

- *Can you use reflected or rotated shapes in a tessellation?* (Yes. Transformed images are congruent to the original shape and tessellations use congruent shapes.)

- *What strategy did you use to fit these shapes together?* (I first lined up congruent sides of two shapes. Then I added on more and more of the shapes.)

- *Do all of the shapes fit together by lining up whole sides?* (No. For H2 and O, only part of the sides lined up.)

Ask the students to complete the rest of the exploration.

## Observe and Assess

As students work, notice the following:

- Do they fit the shapes together successfully?
- Do they understand how a tessellation can be continued in all directions?
- Do they recognize when an arrangement of shapes is not a tessellation?

## Share and Reflect

After students have had sufficient time to work through the exploration, they should form small groups to discuss their observations and answer these questions.

- Which shape cannot make a tessellation?
- Which shapes that made a tessellation were easiest to fit together? Which were hardest?
- Is it possible to make different tessellations with the same shape?

## Answers

**A.** Predictions may vary. Every shape except the pentagon (RP) will tessellate.

**B. and C.** Sample responses:

Shape RH

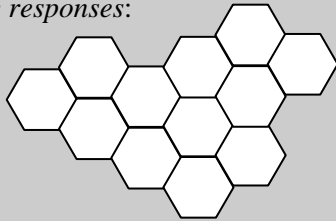

Shape IT

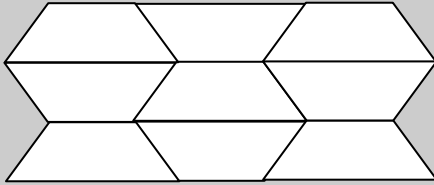

Shape H1

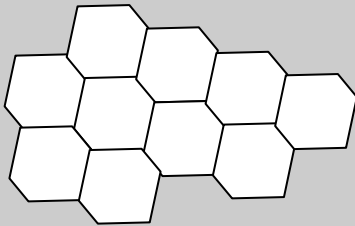

Shape H2

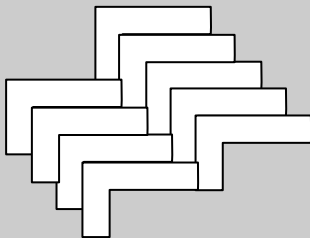

Shape Tra

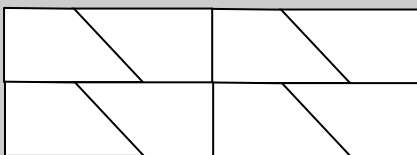

Shape O

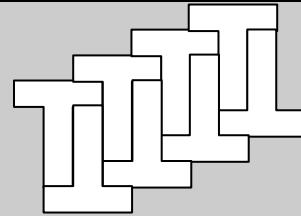

Shape Q

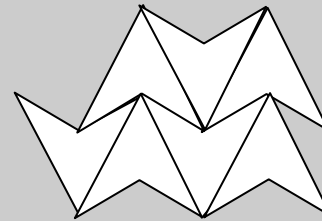

Shape Tri

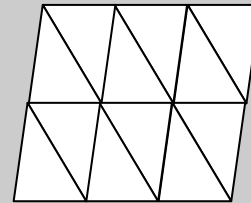

**D.** Sample response:

My predictions were correct for RH, IT, Tri, and Tra, but not for Q.

**E.** Sample response:

I had seen a RH in a honeycomb pattern, so I lined them up side-to-side. I know that two trapezoids fit together to make a hexagon like RH, so I made a lot of hexagons from IT and fit them together like RH. For Tra and Tri, I fit two of them together to make a quadrilateral and then fit the quadrilaterals together, matching congruent sides. For Q, I just tried different ways to fit them together keeping congruent sides lined up.

## Supporting Students

### *Struggling students*

- If students have trouble fitting the shapes together for **parts B and C**, you might suggest that they begin with the hexagons RH or H1, which make a straightforward honeycomb pattern. Some of the other shapes can be arranged to form hexagons that behave in the same way.

For example, IT can be reflected to form a hexagon, and Tra can be reflected twice to form a hexagon.

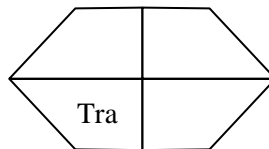
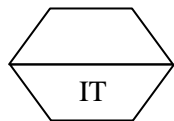

### *Enrichment*

- Students who enjoy a challenge can attempt to make a tessellation with each of the shapes. They can also try to make a tessellation with shapes other than those shown. In particular, you might ask students to test several different triangles and quadrilaterals. Ask them to make a conjecture about the results (any triangle and any quadrilateral can be used to make a tessellation).

## CONNECTIONS: Escher-type Tessellations

- This optional connection highlights the link between geometry and art. Maurits Cornelis Escher lived from 1898 to 1972. Although he was an artist with no mathematical training, much of his work has strong ties to geometry and other branches of mathematics.
- The technique shown is based on translations. The modification of one side is translated to its parallel side and the new shapes are translated to fit together.

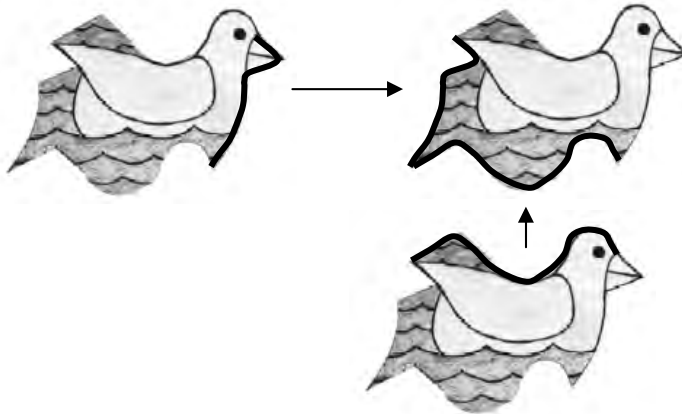

- This technique works for any shape composed of pairs of parallel sides, such as a regular polygon with an even number of sides or a parhexagon (a hexagon with pairs of parallel sides, such as H1 in **lesson 2.1.4**).
- There are similar techniques where shapes are modified using rotations or reflections and then fit together by rotating or reflecting.
- Students who are not artistically inclined may recreate the example shown or they may decorate their shape with a geometric or colour pattern.
- Some students may have difficulty fitting their shapes together if the modification strays outside the lines in a tessellation of the parallelograms.

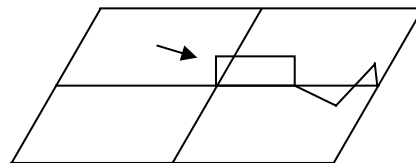

Encourage students to make their modifications so that only two parallelograms are affected by changes to any one side.

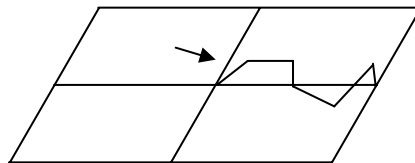



## Chapter 2 2-D Geometry: Shapes and Properties

### 2.2.1 Measuring Angles

Curriculum Outcomes		Outcome relevance
<b>6-D8 Angles: estimate, measure, and draw</b> <ul style="list-style-type: none"> <li>• use a protractor as a tool for measuring angles</li> <li>• estimate, measure, and draw angles from <math>0^\circ</math> to <math>180^\circ</math></li> </ul>		Angle measurement is important to help students understand the properties of shapes as well as create them. It is also critical for fully describing rotations.
Pacing	Materials	Prerequisites
1h	<ul style="list-style-type: none"> <li>• Protractors or Paper Protractors (BLM)</li> <li>• Large paper protractor (optional)</li> <li>• Field Angles (BLM) (optional)</li> </ul>	<ul style="list-style-type: none"> <li>• familiarity with angles and fractions</li> </ul>

#### Main Points to be Raised

- Angles can be measured in units called degrees ( $^\circ$ ).
- There are  $360^\circ$  in one full turn.
- A protractor is a tool used to measure angles in degrees. Many protractors have an outside scale and an inside scale.

#### Try This — Introducing the Lesson

**A.** Allow students to try this alone or with a partner. While you observe students at work, you might ask questions such as the following:

- *How do you know the angle fits 12 times into a full turn?* (I traced the angle around in a circle. There were 12 angles when I was finished.)
- *How can you tell what fraction of a whole turn it is?* (The numerator is 1 and the denominator is the number of times the angle fits into a whole turn.)

#### The Exposition — Presenting the Main Ideas

• Explain to students that in this lesson they will be learning a new way to describe and measure angle sizes. Just as we measure using centimetres rather than fractions of a metre, we can use units called degrees to describe angle size, rather than using fractions of a whole turn.

• As you work together through the exposition on **page 45** of the student text, take time to make sure students understand that the sum of angles that make a whole turn must always be  $360^\circ$ . Ask questions such as:

- *If the whole is divided into three equal angles, what is the size of each of those angles?* ( $360^\circ \div 3 = 120^\circ$ )
- *If an angle is  $45^\circ$ , how big is the other angle that makes the whole?* ( $360^\circ - 45^\circ = 315^\circ$ )

• When you work through the second section of the exposition on **page 46** of the student text, it may be helpful to use a large paper copy of a protractor to measure angles drawn on the board.

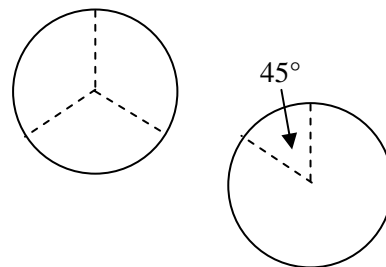

#### Revisiting the Try This

**B.** Students can relate the degree measures of the angles to the fraction of a whole turn they found in **part A**.

#### Using the Examples

• Ask students to work through both examples alone or in pairs. Ask them to try **example 1** before they read through the solution. Encourage them to construct their own angles for **example 2**. Encourage students to use estimation rather than memorizing which scale goes with which zero line to see why an angle is, for example,  $45^\circ$  and not  $135^\circ$ .

## Practising and Applying

### Teaching points and tips

**Q 2:** Not all the angles in this question have one arm horizontal on the page. You might encourage students to turn the protractor or the page before following the method shown in the examples.

**Q 3:** This question emphasizes the role that degree measurements play in understanding the properties of polygons. It provides a context where angle measurement is important.

**Q 5:** For **part b)**, students may use either scale on the protractor.

**Q 6:** This question provides another link to the real world. Some of the line segments are not perfectly straight and some of the angles will be approximate. Students may record their answers on a traced copy of the field or on a copy of the Field Angles BLM.

**Q 7:** This last question provides a link to what students learned about the angles in acute triangles in Class V.

### Common errors

- Many students will use the wrong scale on the protractor when they measure angles or draw angles of a specific size. Here are two strategies for helping them:
  - You might display a large scale copy of the protractors in the last section of the exposition on **page 46** of the student text. Circle or highlight  $0^\circ$  and  $60^\circ$  on the appropriate scales.
  - You could have students practice measuring angles using the single-scale protractors from the Paper Protractors BLM. When students are proficient with those, have them use a double-scale protractor with the outside scale and the inside scale each highlighted in a different colour.
- Make sure that students line up an angle arm with the zero lines and not with the bottom of the protractor.

### Suggested assessment questions from Practising and Applying

<b>Question 1</b>	to see if students can read the measure of an angle from a protractor
<b>Question 2</b>	to see if students understand how to use a protractor to measure an angle
<b>Question 5</b>	to see if students can use a protractor to draw an angle of a given size
<b>Question 7</b>	to see if students can solve a mathematical problem about angle measurements

### Answers

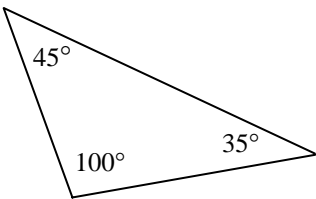
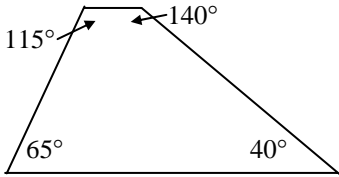
<p><b>A. i)</b> 12 of angle D; 8 of angle E; 6 of angle F.</p> <p><b>ii)</b> Angle D is <math>\frac{1}{12}</math> of a whole turn; angle E is <math>\frac{1}{8}</math> of a whole turn; angle F is <math>\frac{1}{6}</math> of a whole turn.</p>	<p><b>B. i)</b> Angle D is <math>30^\circ</math>; angle E is <math>45^\circ</math>; angle F is <math>60^\circ</math>.</p> <p><b>ii)</b> Angle D is <math>\frac{30}{360}</math>; angle E is <math>\frac{45}{360}</math>; angle F is <math>\frac{60}{360}</math>.</p> <p><b>iii)</b> They are equivalent fractions.</p>
<p><b>1. a)</b> <math>120^\circ</math>    <b>b)</b> <math>140^\circ</math>    <b>c)</b> <math>80^\circ</math>    <b>d)</b> <math>25^\circ</math></p> <p><b>2. Sample responses:</b></p> <p><b>a)</b> About half of <math>90^\circ</math>; <math>45^\circ</math></p> <p><b>b)</b> Just under <math>90^\circ</math>; <math>85^\circ</math></p> <p><b>c)</b> Greater than <math>90^\circ</math>; <math>125^\circ</math></p> <p><b>d)</b> Less than part b); <math>75^\circ</math></p> <p><b>3. a)</b></p> 	<p><b>b)</b></p>  <p><b>4. a) and b) Sample responses:</b></p> <ul style="list-style-type: none"> <li>• Corner of window: estimate <math>90^\circ</math>, actual <math>90^\circ</math>.</li> <li>• Angle between the bottom of the flag and the flagpole in a photo: estimate <math>45^\circ</math>, actual <math>40^\circ</math>.</li> <li>• Angle that the bottom of my book makes with the edge of the table: estimate <math>30^\circ</math>, actual <math>38^\circ</math>.</li> </ul>

5. a) *Sample response:*

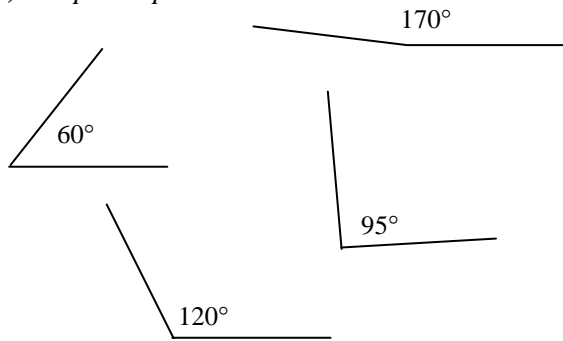

b)

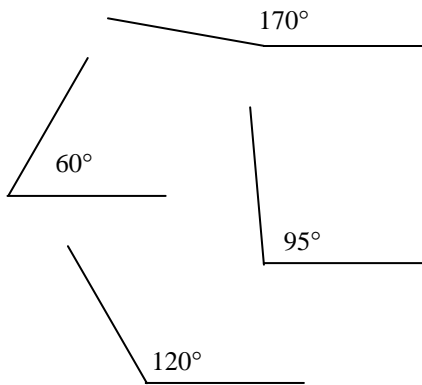

c) *Sample response:*

Within a few degrees; I have to measure some of the estimated angles to tell that they are not the same as the measured angles.

6. a) and b) *Measurements are estimates.*

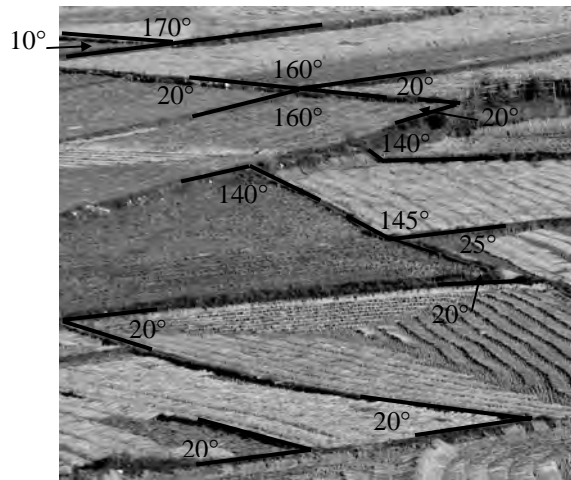

[7. Tashi probably looked at the wrong scale on the protractor.]

## Supporting Students

### *Struggling students*

• If students are struggling with estimating the size of angles in **questions 2, 4, and 5**, you might have them work in pairs to practice measuring.

For example, each student could draw triangles or other polygons for his or her partner to label with angle measures. Students could then check each other's work.

### *Enrichment*

• Refer students to **page 43** in the student text. Ask them to measure the angles in a regular pentagon ( $108^\circ$ ) and a regular hexagon ( $120^\circ$ ). Then ask them to consider the angles that meet at a vertex in a tessellation of regular hexagons. Ask questions such as:

- *What must the angles at the vertex add up to? How do you know? (They must add to  $360^\circ$  because together they make a whole turn.)*

- *Why can you make a tessellation with regular hexagons but not with regular pentagons? (The angles in a regular hexagon are  $120^\circ$ , which goes into  $360^\circ$  three times. Three hexagons can make a whole turn. The angles in a regular pentagon are  $108^\circ$ , which does not go evenly into  $360^\circ$ . You cannot make a whole turn using only the angles in a regular pentagon.)*

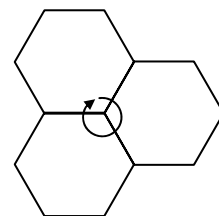

## 2.2.2 Bisectors

Curriculum Outcomes	Outcome relevance
<b>6-E6 Bisectors: angles and line segments</b> <ul style="list-style-type: none"> <li>recognize and describe angle bisectors</li> <li>recognize and describe line segment bisectors, including perpendicular bisectors</li> </ul>	Bisection is an aspect of geometry that is of historical interest. The study of how to create bisectors is a vehicle for exploring properties of shapes.

Pacing	Materials	Prerequisites
1 h	<ul style="list-style-type: none"> <li>Paper squares</li> <li>Rulers</li> <li>Protractors or Paper Protractors (BLM)</li> <li>Angle Bisectors (BLM) (optional)</li> </ul>	<ul style="list-style-type: none"> <li>familiarity with line segments, right angles, and the properties of the diagonals of a square.</li> <li>measuring angles with a protractor</li> </ul>

### Main Points to be Raised

- A bisector divides something into two equal halves:
  - An angle bisector is a line segment that divides an angle in half.
  - A line bisector divides a line segment in half.
- A line bisector that is at right angles to the line segment it bisects is called a perpendicular bisector.
- A line bisectors does not have to be a perpendicular bisector.
- A perpendicular bisector is also an angle bisector because it bisects the  $180^\circ$  angle the line segment creates.

### Try This — Introducing the Lesson

**A.** Allow students to try this alone or with a partner. Distribute a paper square to each student or pair. Explain that folding each crease back and forth will make the pattern clearer and will also make the folding easier to do. While you observe students at work, you might ask questions such as the following:

- How might you have predicted that some of the folds would be cut in half by others or meet at right angles?* (The first two folds were the diagonals of the square and those are properties of the diagonals of a square.)
- Does it make sense that some angles are half of other angles?* (Yes, it makes sense because of the way the paper is folded. When the paper is unfolded, the two angles at a crease are matching angles in congruent triangles.)
- Students can mark their answers to **part B** directly on their square, using both sides if necessary. If students have not folded the square exactly as directed, you might inspect what they have created. It is possible that they will still be able to answer **part B**.

### The Exposition — Presenting the Main Ideas

- Begin by drawing two line segments on the board. Label the endpoints of one B and A, and the endpoints of the other D and E.

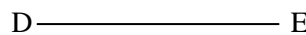
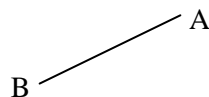

Explain to the class that now it is easy to talk about either line segment specifically because you can use its name — BA or AB, and DE or ED.

Turn BA into an angle by adding another arm. Label the other endpoint C.

Discuss how this angle can be called by its names —  $\angle B$ ,  $\angle ABC$ , or  $\angle CBA$ .

The symbol  $\angle$  is read as “angle”. Have students notice that when a three-letter name is used, the vertex letter is always in the middle.

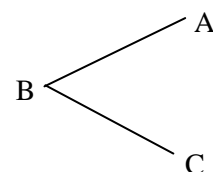

- Ask a volunteer to come to the board to mark the angles that divide  $\angle B$  into two equal angles. Mark the angles with identical symbols and discuss the meaning of the term *angle bisector*.

Continue working through the exposition with the class in this way, calling volunteers to the board to mark various bisectors when you introduce the terms to the students.

## Revisiting the Try This

**B.** This question allows students to make a formal connection between what was done in **part A** and the main ideas presented in the exposition. In this case, they apply the new terminology to their squares.

## Using the Examples

- Work through **example 1** with the students to make sure they understand it.
- Have students read through **example 2** together in pairs. They should then model the solution as shown.

## Practising and Applying

### Teaching points and tips

**Q 1 and 2:** Encourage students to estimate before they measure to check.

**Q 4:** Some students may choose to use a known right angle, such as the corner of a page or a ruler, instead of measuring with a protractor for **part b**). This is acceptable, but it is a good idea to encourage them also to try the questions using a protractor so they get some practice measuring angles.

**Q 5:** This is an important connection to the real world. Encourage students to look for examples of angle bisectors, line bisectors, and perpendicular bisectors in their day-to-day lives.

**Q 6:** This question might be assigned only to selected students. It illustrates a property that is always true — each angle bisector in an equilateral triangle is a perpendicular bisector of the opposite side. Point out that this is not the case with all triangles.

**Q 7:** You might mention that the prefix “bi” means “two”. It is because we are creating two equal line segments or angles that the term bisector is used.

### Common errors

- Many students will look only at one line segment when identifying line bisectors in **question 2**. You might encourage them to sketch the line segments as part of their answer and to label the measurements on either side of the intersection point for both segments.

### Suggested assessment questions from Practising and Applying

<b>Question 1</b>	to see if students can recognize angle bisectors
<b>Question 2</b>	to see if students can recognize line bisectors
<b>Question 3</b>	to see if students can recognize perpendicular bisectors
<b>Question 4</b>	to see if students can draw line bisectors and perpendicular bisectors

## Answers

**A. and B. Sample responses:**

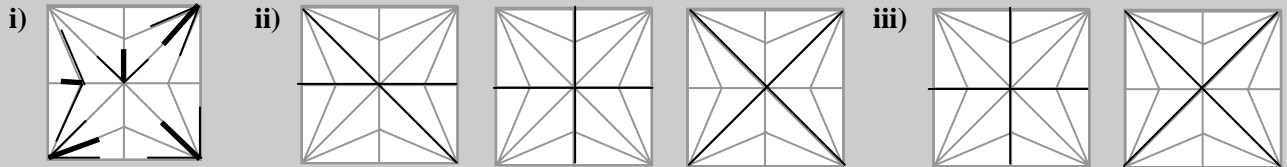

The heavy lines are angle bisectors in part i).

**C. Sample response:**

The horizontal or vertical line of symmetry and one diagonal are bisectors of each other, but are not perpendicular.

There are angle bisectors at each vertex of the square, at the centre where the diagonals meet, and on the sides near the centre.

The perpendicular bisectors are the diagonals of the square and the horizontal and vertical lines of symmetry.

1. A and C; [I measured with a protractor to see if the angles were the same.]

2. A, B, and C; [I measured both line segments on either side of the intersection point to see if they were the same length.]

3. B; [I used a protractor to make sure the two segments met at right angles.]

4. a)

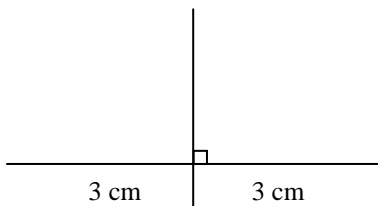

b) *Sample response:*

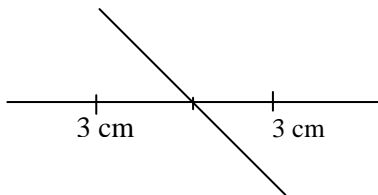

5. *Sample responses:*

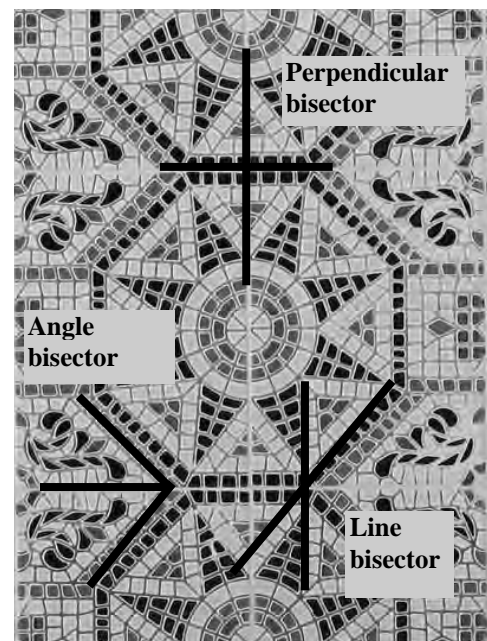

6. a)

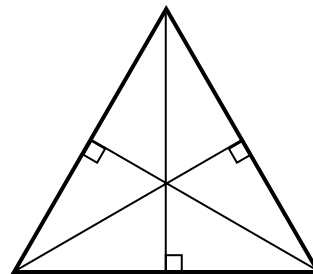

b) Yes; [Both angles at each vertex are  $30^\circ$ .]

7. *Sample response:*

Same: They are the same because they both divide something in half.

Different: They are different because perpendicular bisectors divide both an angle and the line segment in half but other angle bisectors only divide the angle in half.

## Supporting Students

### *Struggling students*

- If students are struggling to measure the angles in **question 1** accurately with a protractor, you might have them check their solutions by folding to see if the angles are bisected.
- You might choose not to assign **question 6** to struggling students.

### *Enrichment*

- Challenge students to create four angles by drawing two line segments that are perpendicular bisectors of each other. Ask them to predict, and then to check, how the angles bisectors of the four angles are related to each other. (They form two line segments that are perpendicular to each other but need not be bisectors of each other.)

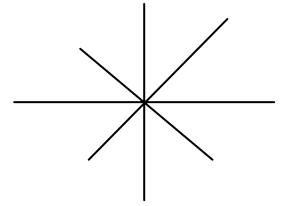

## 2.2.3 EXPLORE: Sorting Quadrilaterals

Curriculum Outcomes	Outcome Relevance
<p><b>6-E7 Quadrilaterals: sort by attributes</b></p> <ul style="list-style-type: none"> <li>• sort concretely by angles</li> </ul> <p><b>6-E8 Diagonal Properties: generalize</b></p> <ul style="list-style-type: none"> <li>• generalize about diagonals for a rhombus: the diagonals are perpendicular to each other and bisect each other, form four congruent right triangles, and are its two lines of reflective symmetry</li> <li>• generalize about diagonals for a parallelogram: the diagonals bisect each other and form two pairs of congruent triangles</li> <li>• generalize about diagonals for a kite: the diagonals are perpendicular and form two pairs of congruent right triangles; one of the diagonals is bisected, and the other diagonal is a line of reflective symmetry</li> <li>• understand that there are no special properties of the diagonals of a general trapezoid</li> </ul>	<p>The study of geometry focuses on the exploration of properties of shapes. Now that students are familiar with the measurement of angles and the bisection of angles and lines, they can use these properties to compare shapes.</p>

Pacing	Materials	Prerequisites
1.5 h	<ul style="list-style-type: none"> <li>• Sorting Quadrilaterals (BLM) (optional)</li> <li>• Scissors</li> <li>• Rulers</li> <li>• Protractors or Paper Protractors (BLM)</li> </ul>	<ul style="list-style-type: none"> <li>• familiarity with quadrilaterals and some of the properties of the diagonals of rectangles</li> <li>• measuring angles with a protractor</li> <li>• identifying and creating lines of symmetry, angle bisectors, line bisectors, and perpendicular bisectors</li> <li>• classifying triangles by angle and by side length</li> </ul>

### Exploration

<ul style="list-style-type: none"> <li>• Work through the introduction (in white) with the students. Tell them that they will be investigating properties of the diagonals of different quadrilaterals. Point out that there are two different examples of each type of quadrilateral, except for the square and the rectangle, which they studied in Class V.</li> <li>• Have students work in pairs or in small groups. Distribute scissors and a copy of Sorting Quadrilaterals (BLM) (or have students trace the quadrilaterals in the text).</li> <li>• Discuss <b>part B</b> with the students to make sure they know what to do.</li> <li>• Make sure students refer only to quadrilaterals in their answer to <b>part C</b>.</li> </ul> <p>While you observe students at work, you might ask questions such as the following:</p> <ul style="list-style-type: none"> <li>• <i>How did you decide whether the diagonals were line bisectors or angle bisectors?</i> (I measured with a protractor to see if they were the same.)</li> <li>• <i>How did you know the triangles were right triangles?</i> (I knew the diagonals were perpendicular to each other, so the triangles had to be right triangles.)</li> <li>• <i>What aspect of the quadrilaterals do you think determines the answers?</i> (I think it depends on whether the sides are parallel or congruent because that is what tells you what kind of quadrilateral it is.)</li> <li>• <i>Do you think that your answers will be the same for other examples of these types of quadrilaterals?</i> (Yes.)</li> </ul>
--

### Observe and Assess

As students work, notice the following:

- Do they understand how to determine line bisectors and angle bisectors?
- Do they correctly identify perpendicularity?
- Do they successfully classify the triangles by side length and by angle?
- Do they recognize congruent triangles?



## Share and Reflect

After students have had sufficient time to work through the exploration, they should form small groups to discuss their observations and answer these questions.

- How do the diagonals of a rhombus compare to the diagonals of a square?
- How do the diagonals of a parallelogram compare to the diagonals of a rectangle?
- How would you describe the properties of the diagonals of a kite? of a trapezoid?

## Answers

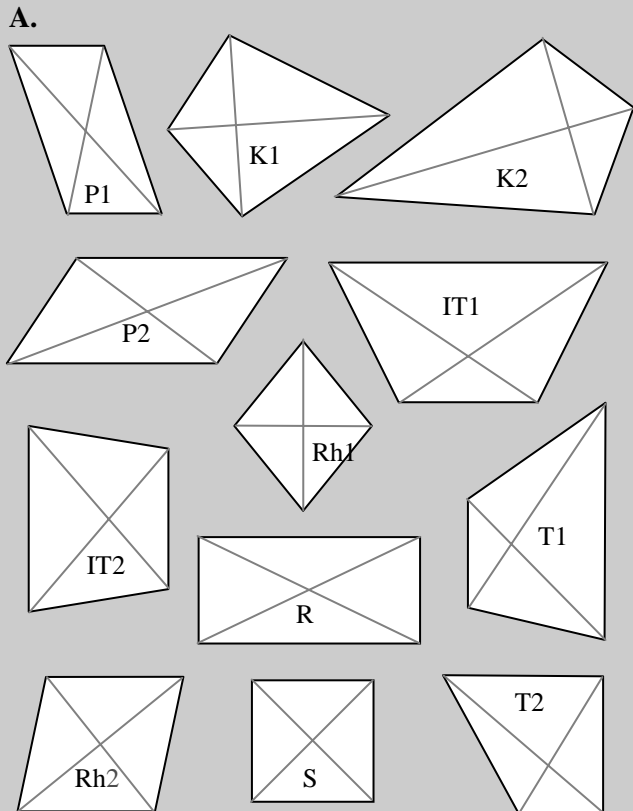

**B. i)**

The diagonals bisect each other	P1, P2, Rh1, Rh2, R, S
One diagonal bisects the other	K1, K2
Neither diagonal bisects the other	IT1, IT2, T1, T2
The diagonals are perpendicular to each other	K1, K2, Rh1, Rh2, S
Both diagonals bisect the angles of the quadrilateral	Rh1, Rh2, S
One diagonal bisects the angles of the quadrilateral	K1, K2
Both diagonals are lines of symmetry	Rh1, Rh2, S
One diagonal is a line of symmetry	K1, K2
Neither diagonal is a line of symmetry	P1, P2, R, IT1, IT2, T1, T2

**ii)**

four congruent right scalene triangles	Rh1, Rh2
four congruent right isosceles triangles	S
two pairs of congruent triangles - one pair obtuse scalene - one pair acute scalene	P1, P2
two pairs of congruent triangles - one pair obtuse isosceles - one pair acute isosceles	R
two pairs of congruent right scalene triangles	K1, K2
one pair of congruent acute scalene triangles and two non-congruent triangles	IT1, IT2
four non-congruent triangles	T1, T2

**C. i)** Rhombus or square

**ii)** Kite, rhombus, or square

## Supporting Students

### *Struggling students*

- If students are struggling to determine angle bisectors or to classify the triangles in **part B**, you might suggest that they fold them to compare angles and side lengths. It may also help to mark congruent angles and sides.

### *Enrichment*

- Challenge students who enjoy this material to make up a list of questions like the questions in **part C**. They can exchange lists with a classmate and answer each other's questions.

## GAME: Go Fish

This optional game allows students to practice thinking about and classifying quadrilaterals by the properties of their diagonals.

- Encourage players to think about all the different properties the diagonals may possess. They should consider questions such as:
  - Are either or both of the diagonals bisectors?
  - Are the diagonals perpendicular to each other? Are the angle bisectors of the quadrilateral angles perpendicular to each other? Are the lines of symmetry perpendicular to each other?
  - How many congruent triangles are formed?
  - What types of triangles are formed?
- The game can also be played as a Dominoes-style game, where you can add a card to the train if the diagonal properties match.

## Chapter 3 3-D Shapes

### 2.3.1 EXPLORE: Planes of Symmetry

Curriculum Outcomes		Outcome Relevance
<b>6-E9 Planes of Symmetry: 3-D shapes</b> <ul style="list-style-type: none"><li>• understand that some 3-D shapes have planes of reflective symmetry</li><li>• investigate cubes, cones, cylinders, prisms, and pyramids for planes of symmetry</li></ul>		This essential exploration focuses on the planes of symmetry of 3-D objects. These two dimensional slices of the 3-D object help you to understand its structure. Understanding 3-D objects and representing them in two dimensions is relevant to real-world applications.
Pacing	Materials	Prerequisites
1 h	<ul style="list-style-type: none"><li>• Cubes</li><li>• Sample Net of Cube (BLM) (optional)</li></ul>	<ul style="list-style-type: none"><li>• building cube structures</li><li>• familiarity with basic properties of prisms, pyramids, cones, cylinders, and lines of symmetry</li><li>• familiarity with the term <i>congruent</i></li></ul>

#### Exploration

- Work through the introduction (in white) with the students. Make sure that they understand that there can be many ways to cut an object into two congruent halves.
- Have students work in pairs or small groups. Distribute 12 cubes to each pair or group. Discuss the exploration with the students to make sure they know what they are expected to do. They do not need to record their answers for **part A**, but students should be prepared to describe what they did.

While you observe students at work, you might ask questions such as the following:

- *Are there planes of symmetry that you cannot split the cubes to show?* (Yes. The diagonal plane of symmetry shown in the introduction is impossible to make when a cube is built from smaller cubes. For the rectangular prism, there is a vertical plane of symmetry that goes through the middle cubes on the top face.)
- *Do you think all cube structures have planes of symmetry that you cannot split the cubes to show?* (No. The L-shaped cube structure has only one plane of symmetry and I can split the cubes to show it.)
- *Do the lines of symmetry of different faces help you find some planes of symmetry?* (Yes. That happened with the cube.)

#### Observe and Assess

As students work, notice the following:



- Do they successfully split the cube structures into two congruent halves?
- Can they visualize the planes of symmetry from a drawing of an object?
- Do they sketch or describe the planes of symmetry in **part B** reasonably well?

#### Share and Reflect

After students have had sufficient time to work through the exploration, they should form small groups to discuss their observations and answer these questions.

- *How can you use the lines of symmetry of the base to help you find planes of symmetry of a prism?*
- *What other planes of symmetry might there be for a prism?*
- *Does a pyramid have planes of symmetry that do not correspond to a line of symmetry of the base?*

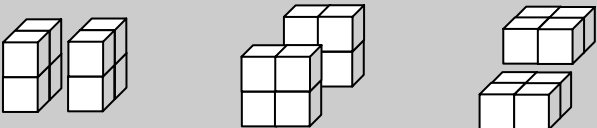
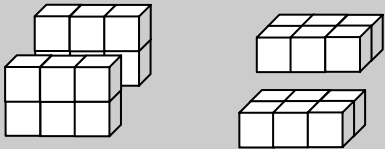
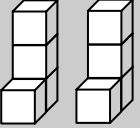
## Answers

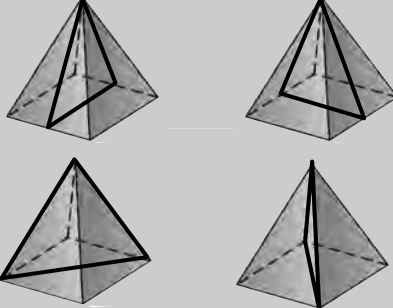
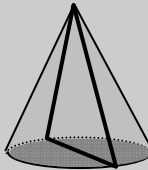
<p><b>A. i)</b></p>  <p><b>ii)</b></p>  <p><b>iii)</b></p> 	<p><b>B. ii)</b></p>   <p><b>iii)</b> Any slice along the diameter of the base and through the top of the cone works.</p>
<p><b>B. i)</b></p> 	 <p>Cone</p> <p><b>C. i)</b> Unlimited; through any possible diameter.  <b>ii)</b> Unlimited; through any possible diameter and the vertex.</p>

## Supporting Students

### Struggling students

- If students are struggling with **part B**, you might have them try to model the structures in clay or dough, then cut each structure with a string to see if that divides it into two equal halves. The surface of the cut is the plane of symmetry.

### Enrichment

- For an extra challenge, you might ask students to find all of the planes of symmetry of a cube. (There are nine, corresponding to the lines of symmetry of the faces of a cube as shown.)

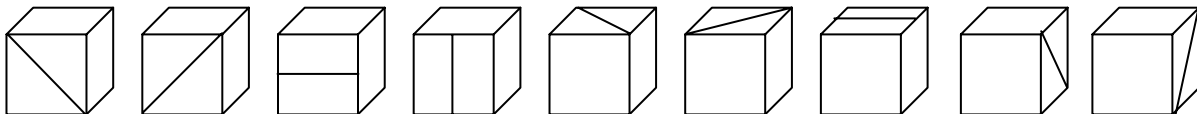

## 2.3.2 EXPLORE: Cross-sections

Curriculum Outcomes	Outcome Relevance
<p><b>6-E10 Cross Sections: cones, cylinders, prisms, and pyramids</b></p> <ul style="list-style-type: none"> <li>• understand that a cross-section is the 2-D face produced when a straight cut is made through a 3-D shape</li> <li>• examine the properties of cross-sections concretely (e.g., cone: if a cut is made parallel to its base, the cross-section face produced is a circle; if a cut is made through its vertex and perpendicular to its base, the cross-section face is a triangle)</li> </ul>	<p>This essential exploration focuses on the planes of symmetry of a 3-D object. Understanding how a 3-D object can be cut up into 2-D sections will not only help students better understand the properties of the object, but it will also help them make more sense of volume formulas later on.</p>

Pacing	Materials	Prerequisites
1 h	<ul style="list-style-type: none"> <li>• Clay or dough</li> <li>• String or thin wire</li> <li>• Sample Net of Triangle-based Prism (BLM) (optional)</li> <li>• Sample Net of Rectangle-based Prism (BLM) (optional)</li> <li>• Sample Net of Square-based Pyramid (BLM) (optional)</li> <li>• Sample Net of Hexagon-based Prism (BLM) (optional)</li> </ul>	<ul style="list-style-type: none"> <li>• familiarity with prisms, pyramids, cylinders, cones, and polygons</li> </ul>

### Exploration

<ul style="list-style-type: none"> <li>• Work through the introduction (in white) with the students. Point out that a plane of symmetry is a cross-section, but that a cross-section does not have to divide the shape into two congruent halves. Discuss the pentagon-based pyramid shown. Ask them which cross-section is also a plane of symmetry (the triangle cross-section, but not the pentagon cross-section). The introduction shows only cross-sections that are parallel or perpendicular to the base, but it is possible to make other cross-sections.</li> </ul> <p>For example, cutting off the corner of a cube results in a triangle cross-section.</p> <ul style="list-style-type: none"> <li>• Have students work alone or in pairs. Distribute the clay or dough and the string or thin wire to use for <b>part A</b>. While you observe students at work, you might ask questions such as the following:</li> <li>• <i>How did the cross-sections for the square-based pyramid compare to the cross-sections for the pentagon-based pyramid in the introduction?</i> (The triangle and trapezoid cross-sections were the same, but instead of pentagons, there were squares.)</li> <li>• <i>How were the cross-sections of the prism different from the cross-sections of the pyramid?</i> (The cross-sections that were parallel to the base did not change in size for the prism but they did change for the pyramid.)</li> <li>• <i>How were the cross-sections for the cone different from all of the others?</i> (Some of them were not polygons. They had a rounded side but they were not circles.)</li> </ul>
---

### Observe and Assess

As students work, notice the following:

- Do they model the shapes successfully?
- Do they understand the concept of a cross-section?
- Do they recognize the 2-D shapes of the cross-sections?
- Do they realize that many cross-sections are possible for most objects?

## Share and Reflect

After students have had sufficient time to work through the exploration, they should form small groups to discuss their observations and answer these questions.

- How can you predict some of the cross-sections for pyramids and cones?
- What happens to the cross-sections that are parallel to the base of a pyramid or a cone as you move farther away from the base?
- How can you predict some of the cross-sections for a prism and a cylinder?
- What happens to the cross-sections that are parallel to the base of a prism or a cylinder as you move farther away from the base?

## Answers

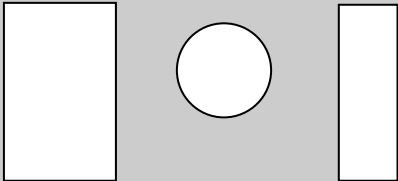
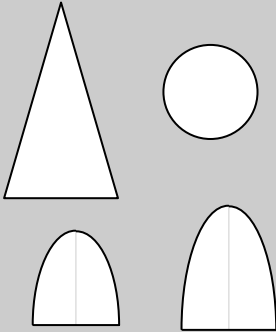
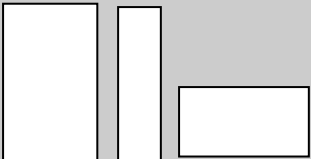
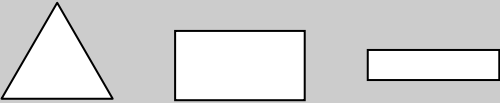
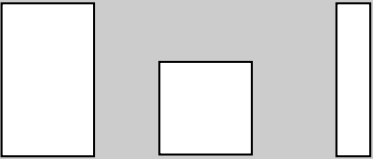
<p><b>A. Sample responses:</b></p> <p>Cylinder:</p>  <p>Cone:</p>  <p>Rectangle-based prism:</p> 	<p>Triangle-based prism:</p>  <p>Square-based prism:</p>  <p><b>B.</b> Hexagons that are all the same size, and rectangles of different sizes.</p>
---	--

## Supporting Students

### Struggling students

- If students are struggling to make the shapes in **part A**, you might provide paper structures made from the various nets (BLMs) as a visual aid. This will also help them visualize the cross-sections in **part B**.

### Enrichment

- For **part A**, you might challenge students to look at cross-sections that are not parallel or perpendicular to the base. If metal or plastic shapes are available, they can be filled with water and tilted. The surface of the water reveals the shape of a cross-section.

## 2.3.3 Interpreting Orthographic Drawings

Curriculum Outcomes		Outcome relevance
<b>6-E11 Orthographic Drawings: make and interpret</b> <ul style="list-style-type: none"><li>• make and interpret structures built from cubes</li><li>• understand that orthographic drawings are a set of 2-D views of a 3-D structure drawn by looking at it from the front, sides, top, and back</li></ul>		Orthographic drawings are a useful way to represent real-world 3-D structures in two dimensions. This lesson focuses on the interpretation of these drawings, which are often used by architects and engineers.
Pacing	Materials	Prerequisites
1.25 h	<ul style="list-style-type: none"><li>• Linking cubes</li><li>• Sample Net of Cube (BLM)</li></ul>	<ul style="list-style-type: none"><li>• building cube structures</li></ul>

### Main Points to be Raised

- Orthographic drawings are 2-D drawings of a 3-D structure.
- Orthographic drawings can include the front, back, top, left, and right views.
- A change of depth in the structure is usually shown with a heavier line.
- A structure may have cubes that are not visible in an orthographic drawing.

### Try This — Introducing the Lesson

**A.** Allow students to try this alone or with a partner. Distribute 12 cubes to each student or pair. If there are not enough cubes, students can work in small groups. While you observe students at work, you might ask questions such as the following:

- *Is this the only structure that could be built to match the drawings?* (No. I see different structures from other groups.)
- *Which cubes are you certain are in the structure?* (I know exactly what the back layer of cubes looks like, and what the layer of cubes on the right looks like.)
- *Where might there be hidden cubes?* (There could be cubes on the left side that some people include, but others do not.)
- If students build a structure that does not match the face views, you might gently suggest that they view their structure from the back and from the right to compare it to the drawings.

### The Exposition — Presenting the Main Ideas

• Draw students' attention to the exposition on **page 59** of the student text. As you read through the material together, you might ask questions about the structure they built in the **Try This** section:

- *Which views have a change of depth line?*
- *What does the top view look like?*
- *What does the left view look like?*
- Emphasize that a single face view does not give enough information to build a cube structure. There could be several structures with the same face view.
- Build several different structures for students to see. As a class, discuss for each structure what each view would look like, and whether and where to show depth lines.

### Revisiting the Try This

**B.** This question reinforces the fact that even having two views of an object does not ensure that there is only one possible object.

## Using the Examples

• Assign students to pairs. One student in the pair should become the expert on **example 1** and the other should become the expert on **example 2**. Each should then explain his or her example to the other student. Encourage students to build the cube structures themselves. You may need to help students with **example 2** by discussing why the student might have chosen to start with the top view or how she would have proceeded if she had started with a different view.

## Practising and Applying

### Teaching points and tips

**Q 1:** You might suggest that students choose one face view to consider and then go through the given face views one by one to see if they match.

**Q 2:** You might suggest that students follow **example 2** for this question.

**Q 4:** This question might be assigned only to selected students, especially those who do well with **question 3**. Students should find this question a little more challenging.

**Q 6:** Use this last question to draw attention to the fact that a single orthographic drawing does not give enough information to create a cube structure (unless the structure is very simple).

### Common errors

- Many students confuse the left and right views in **question 1**. Remind them that a face view shows you what the structure looks like straight on from that side. Encourage them to visualize the structure from that angle.
- Some students have difficulty critiquing Dawa's orthographic drawings in **question 5**. You might remind them that the change of depth lines are an important part of an orthographic drawing.

### Suggested assessment questions from Practising and Applying

<b>Question 1</b>	to see if students can identify the face views of a cube structure
<b>Question 2</b>	to see if students can build a cube structure given the face views
<b>Question 5</b>	to see if students can interpret and evaluate the accuracy of the face views of a cube structure

## Answers

**A. and B. Sample responses:**

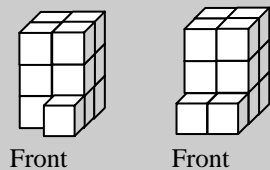

- 1. a)** Back  
**d)** Left

- b)** Front  
**e)** Top

- c)** Right

- 2. a)**

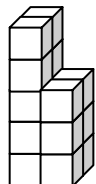

Front

- b)**

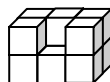

Front

- 4.**

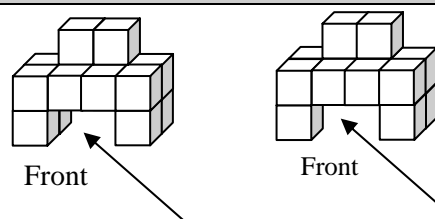

One extra cube in the left structure.

- 5. a)** Add a heavy vertical line to show the change in depth.

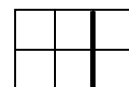

- b)** The heavy line should be vertical, not horizontal.  
**c)** This is a good drawing.

- 3. a)**



Front

- b)**



Front

[**6.** If you have only one view, there might be more than one structure to match it. The more views you have, the more sure you can be that you have built the right structure.]



## Supporting Students

### *Struggling students*

- If students are struggling with identifying the face views in **question 1**, let them build the structure with cubes. You might encourage them first to predict their answers and then to use the cubes to check their answers.
- You might choose not to assign **question 4** to struggling students.

### *Enrichment*

- For the cube structure shown in **question 5**, you might challenge students to build cube structures that look the same from the view shown but that have hidden cubes. Ask them which face views would be different and how they would be different.

## 2.3.4 Creating Orthographic Drawings

Curriculum Outcomes		Outcome relevance
<b>6-E11 Orthographic Drawings: make and interpret</b> <ul style="list-style-type: none"> <li>• make and interpret structures built from cubes</li> <li>• understand that orthographic drawings are a set of 2-D views of a 3-D structure drawn by looking at it directly from the front, sides, top, and back</li> </ul>		Orthographic drawings are a useful way to represent real-world 3-D structures in two dimensions. This lesson focuses on creating these drawings.
Pacing	Materials	Prerequisites
1.25 h	<ul style="list-style-type: none"> <li>• Linking cubes</li> <li>• Sample Net of Cube (BLM) (optional)</li> <li>• Grid paper or Small Grid Paper (BLM)</li> </ul>	<ul style="list-style-type: none"> <li>• building and interpreting cube structures</li> </ul>

### Main Points to be Raised

- When you make orthographic drawings, it is helpful to place the structure on a paper with front, back, right, and left marked.
- Look at the structure straight on from the desired view and draw what you see.
- Look at the structure from a slightly different view to help you identify changes in depth.

### Try This — Introducing the Lesson

**A.** Allow students to try this alone or with a partner. Distribute at least 7 cubes to each student or pair. If there are not enough cubes, students can also work in small groups. While you observe students at work, you might ask questions such as the following:

- *What is the best position from which to look at the structure in order to draw the top view?* (The best position is looking down on it from directly above.)
- *What about when you draw the front view?* (In front of it, looking directly at the front.)
- *When you look at the structure so that you can draw a face view, can you tell how many cubes are behind the cubes you are drawing?* (No. There could be cubes behind them that you would not be able to see from that view.)

### The Exposition — Presenting the Main Ideas

- Distribute cubes (5 per student or pair) and grid paper (one sheet per student) to the class. Take a moment to have each student create his or her own building mat marked with front, back, left, and right, as shown in the exposition on **page 63** of the student text.
- Work through the exposition together as a class. Be sure students have ample time to practice drawing:
  - the front view and top view shown in the text
  - the back view
  - the right view
  - the left view
- Encourage students who finish these tasks quickly to build another structure and create a set of orthographic drawings for it.

### Revisiting the Try This

**B.** Students apply the techniques for drawing face views taught in the exposition to a new cube structure.

## Using the Examples

- Have students work in pairs or small groups. It may be convenient to use the same groupings as in the **Try This**. Distribute linking cubes (6 per pair or group) and grid paper (1 sheet per student).
- Work through the example with the students to make sure they understand it. Make sure that they understand that they are free to start with any view they wish. Mention that people often do not draw all the face views if an object is symmetric. You may discuss why, if you know an object is a cube, there is no point in drawing both left and right views. However, if the object is irregular, it may be important to draw both views.

## Practising and Applying

### Teaching points and tips

**Q 1 to 4:** To ensure success, you might suggest that students follow the example when they draw the face views.

**Q 3:** Encourage students to try to visualize the faces to draw them. If you feel that they would benefit from building the structure, have students work in groups. This structure is made of 28 cubes.

**Q 4:** You might suggest that students first try to visualize the structure to draw the requested face views, and then build the structure to check their work. You could have students work in small groups. This structure requires 16 cubes.

**Q 6:** Use this question to draw attention to the fact that different structures can have the same orthographic drawings for some views.

### Common errors

- Many students will confuse the face views when they are creating orthographic drawings in **questions 1 and 2**. Suggest that students continue to use their building mats from the exposition. Encourage them to turn the mat to see the structure from different views rather than turning the structure itself.

### Suggested assessment questions from Practising and Applying

<b>Question 1</b>	to see if students can create orthographic drawings from models of simple cube structures
<b>Question 3</b>	to see if students can create orthographic drawings from a drawing of a cube structure
<b>Question 5</b>	to see if students can build and draw cube structures with certain properties relating to their face views

## Answers

**A. Sample response:**

**i)**

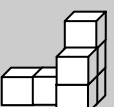

Front

**ii)**

Top view



Left view

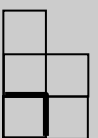

Right view

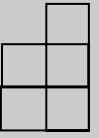

Back view

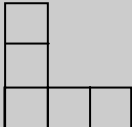

Front view

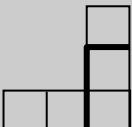

**B. i)**

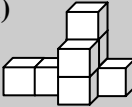

Front

Top view

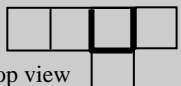

Left view

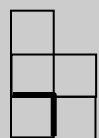

Right view

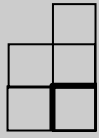

Back view

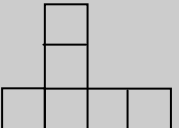

Front view

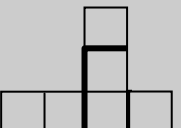

**ii)**

- I added a single square to top, back, and front views.
- I added heavier lines to the right and front views.
- The left view did not change.

**Answers [Continued]**

**1. a) Views**

Top, Front, Left, Right, Back

**b) Views**

Top, Front, Right, Left, Back

**c) Views**

Top, Front, Left, Right, Back

**2. Sample responses:**

**a) Structure**

Front, Top, Front, Left, Right

**b) Structure**

Front, Top, Front, Left, Right

**3. a)**

Front and back view

**b)**

Left and right view

**c)**

Top view

**d)**

Bottom view

**4. Sample responses:**

**a)**

Front

**b)**

Top view

**c)**

Front view

**d)**

Right view

**5. Sample response:**

**Structure Views**

Front, Front and right, Top

**Structure Views**

Front, Front, Right, Top

**6. Yes.** [There could be cubes that you can only see from the back, so removing them would make a different structure but would leave all of the other views the same.]

**Supporting Students**

**Struggling students**

• If students are struggling to draw the face views of the cube structures in **question 1**, you might have them work with a stronger partner to draw very simple structures first.

For example, have them use one cube, then two cubes, then three cubes connected in different ways.

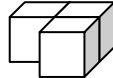
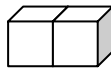

As they become more proficient at drawing face views, they can attempt more complicated structures of their own making for extra practice.

**Enrichment**

• Some students might enjoy building and drawing face views for complicated cubes structures. They may also enjoy creating orthographic drawings of everyday items, such as books, various containers, chairs, or tables.

# UNIT 2 Revision

Pacing	Materials
2 h	<ul style="list-style-type: none"> <li>• Grid paper or Small Grid Paper (BLM)</li> <li>• Rulers</li> <li>• Protractors</li> <li>• Paper Protractors (BLM) (optional)</li> <li>• Sample Net of Square-based Pyramid (BLM) (optional)</li> <li>• Linking cubes (7 per student)</li> <li>• Sample Net of Cube (BLM) (optional)</li> </ul>

Question	Related Lesson(s)
1	Lesson 2.1.1
2 and 3	Lesson 2.1.2
4	Lesson 2.1.3
5	Lesson 2.1.4
6 and 7	Lesson 2.2.1
8 – 10	Lesson 2.2.2
11 and 12	Lesson 2.2.3
13	Lessons 2.1.2 and 2.2.3
14 and 15	Lessons 2.3.1 and 2.3.2
16 and 18	Lesson 2.3.3
17, 19, and 20	Lesson 2.3.4

## Revision Tips

**Q 1 and 5:** Provide grid paper for students to use.

**Q 9:** Remind students to look at both line segments when they check for bisection.

**Q 11 and 12:** If necessary, review the different types of quadrilaterals from **lesson 2.2.3**. You might suggest that students sketch each quadrilateral together with its diagonals before formulating their answers.

**Q 13:** This question provides a link between **chapter 1** and **chapter 2**. Students can mark their answers on traced copies of the design.

**Q 15:** You might provide a model of a square-based pyramid for students to use.

**Q 16 and 17:** Some students may choose to use the picture of the cube structure to answer these questions, while other students may prefer to build the structure with cubes. Either approach is acceptable.

**Q 18:** The cube structures are not labelled with “front” in this question. Encourage students to consider different possible front views of the structures when they answer this question.

## Answers

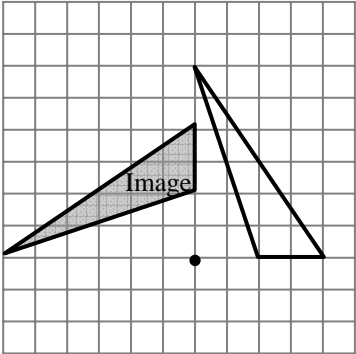
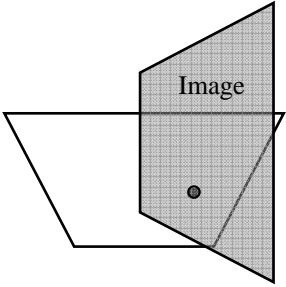
<p><b>1. a)</b></p> 	<p><b>b)</b></p> 
---	---

**Answers [Continued]**

**1. c)**

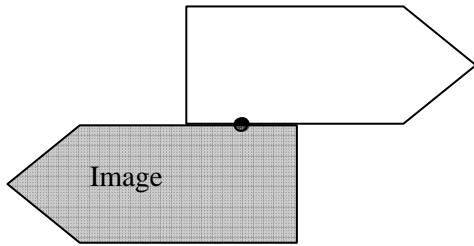

**2. a) 2;** [*Sample response:* There are two identical arrows.]

**b) 1;** [*Sample response:* There is only one longest side.]

**c) 3;** [*Sample response:* Each point is the same.]

**d) 4;** [*Sample response:* There are four identical arrows.]

**3. Turn symmetry of order 6;** [*Sample response:* There are 6 congruent sides and angles. As the hexagon is turned a full turn around its centre, it will line up with itself 6 times.]

**4. a) Sample response:** Reflect horizontally and then vertically across the lines shown.

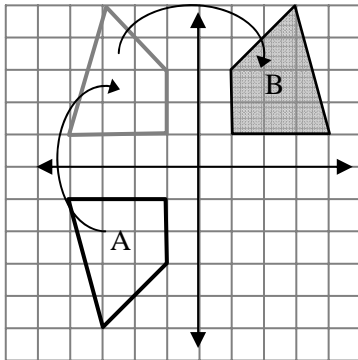

**b) Rotate a  $\frac{1}{2}$  turn cw or ccw around the point shown.**

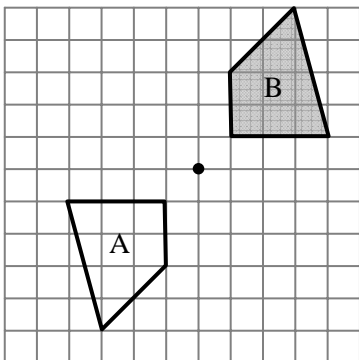

**5. Yes;** [*Sample response:*

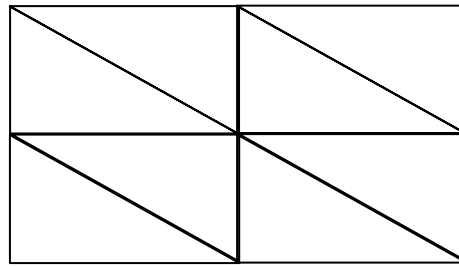

**6. a)  $55^\circ$**

**b)  $110^\circ$**

**7. a)**

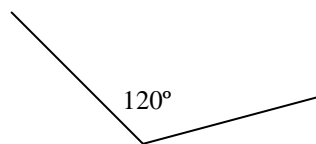

**b)**

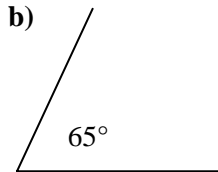

**8. A, B, and D;** [*Sample response:*

I measured each angle with a protractor to see if they were the same size.]

**9. B, C, and D;** [*Sample response:*

The line segments in B bisect each other. The vertical line segment in C is bisected by the horizontal line segment. The slanted line segment in D is bisected by the vertical line segment. I measured with a ruler to see if the lengths on both sides of the intersection points were the same.]

**10.**

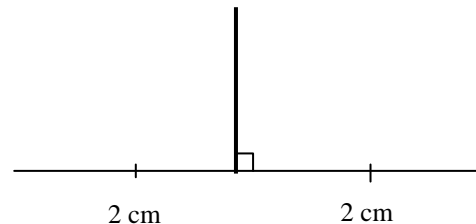

**11. Alike:**

- Both divide the shape into two pairs of congruent triangles.

**Different:**

- The triangles are right triangles for a kite; there is one pair of obtuse and one pair of acute triangles for a rectangle.

- Diagonals of rectangle bisect each other; in a kite, only one diagonal is bisected.

**12. a) One pair of congruent triangles and one pair not congruent**

**b) Two pair of congruent triangles — one pair acute scalene, one pair obtuse scalene**

**c) Four congruent right triangles**

**13. Sample responses:**

**a) Angle bisectors**

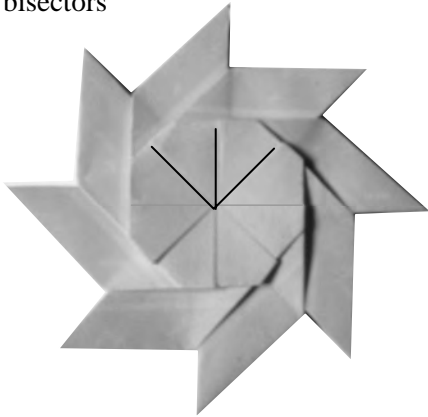

**b) Perpendicular bisectors**

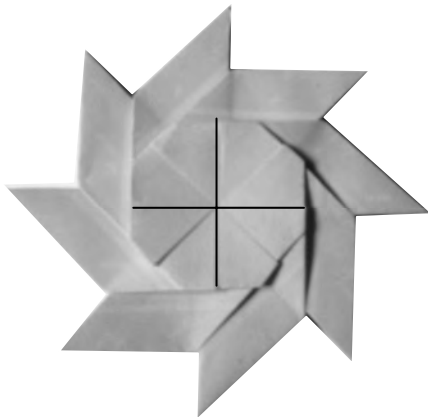

**c) Non-perpendicular bisectors**

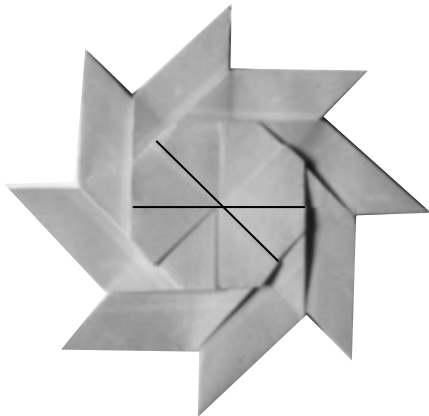

**d) Rotational symmetry of order 8 with the turn centre where the bisectors intersect.**

**14. a)**

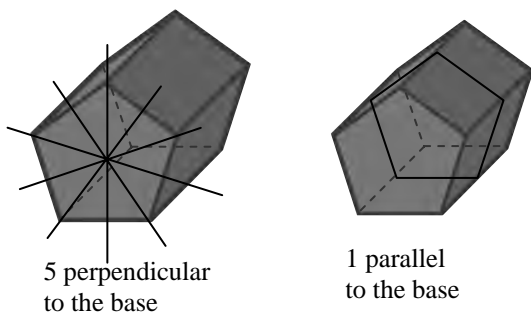

**14. b) Sample response:**

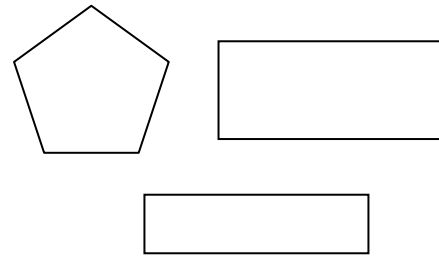

**15. a)** The triangular cross-sections are perpendicular to the base and run through the top vertex. The trapezoid cross-sections are perpendicular to the base but do not go through the top vertex. The cross-sections parallel to the base are all squares of different sizes.

**b)** Only the triangular cross-sections are also planes of symmetry.

**16. A**

**17. B**

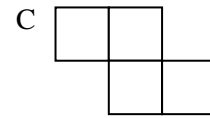
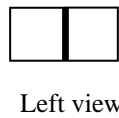

**18. A;** [Both structures match the top view, but the left view and front view of structure B each need another cube on the bottom right corner.]

**19. Sample responses:**

**a)**

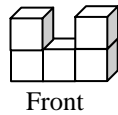

**b)**

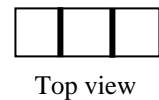
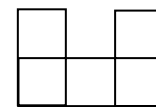

**20. a)**

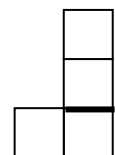
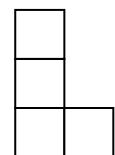
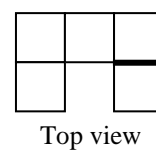
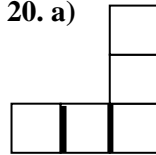

**b)**

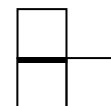
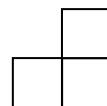
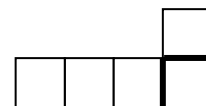
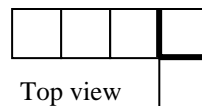

## UNIT 2 Geometry Test

1. Trace the shape and turn centre shown below. Rotate the shape a  $\frac{3}{4}$  turn ccw around the turn centre. Show your work.

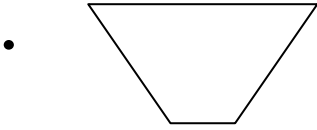

2. Predict the order of turn symmetry of each shape. Explain each prediction.

a)

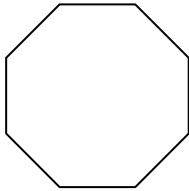

b)

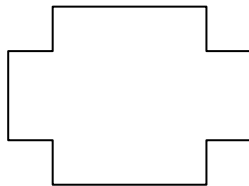

3. Describe how you can transform Shape A to Shape B using each.

- a) a combination of two or more transformations  
 b) a single transformation

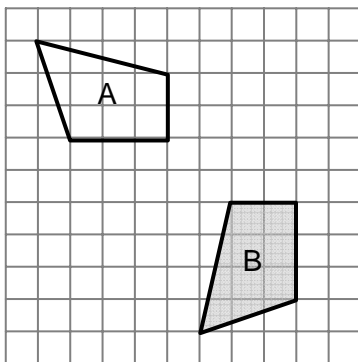

4. Is this a tessellation? Explain how you know.

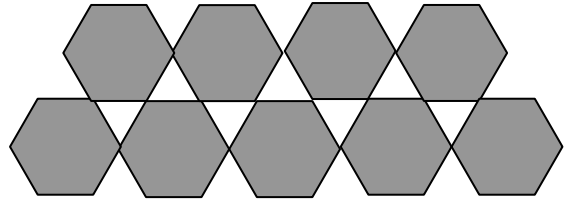

5. Use a protractor to measure the three angles in this triangle.

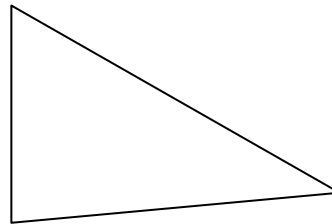

6. Does each diagram below show an angle bisector? Tell how you know.

a)

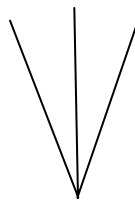

b)

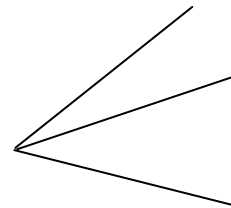

7. Draw a line segment. Draw another line segment that bisects it but is not a perpendicular bisector.

8. How is the result of drawing the diagonals of an isosceles trapezoid different from the result of drawing the diagonals of a non-isosceles trapezoid? How are the results alike?



**9.** Examine this hexagon-based pyramid. The base is a regular hexagon.

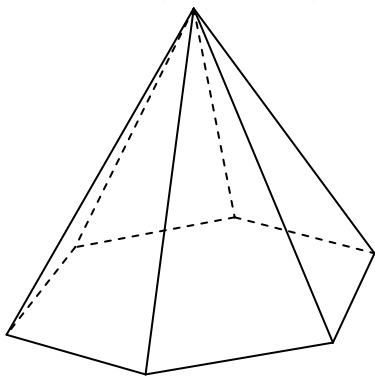

- a)** Describe or sketch the planes of symmetry.
- b)** Describe or sketch three or more cross-sections.

**10. a)** Which view matches the cube structure? Explain your thinking.

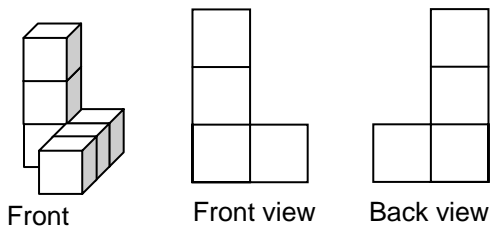

**b)** For the view that does not match, explain how you would change it to make it match.

**11.** Build a cube structure using 7 linking cubes. Draw two different views of your structure.

# UNIT 2 Test

Pacing	Materials
1 h	<ul style="list-style-type: none"> <li>• Rulers</li> <li>• Protractors</li> <li>• Paper Protractors (BLM) (optional)</li> <li>• Linking cubes (7 per student)</li> <li>• Sample Net of Cube (BLM) (optional)</li> </ul>

Question	Related Lesson(s)
1	Lesson 2.1.1
2	Lesson 2.1.2
3	Lesson 2.1.3
4	Lesson 2.1.4
6	Lesson 2.2.1
6 and 7	Lesson 2.2.2
8	Lesson 2.2.3
9	Lessons 2.3.1 and 2.3.2
10	Lesson 2.3.3
11	Lesson 2.3.4

Select questions to assign according to the time available.

## Answers

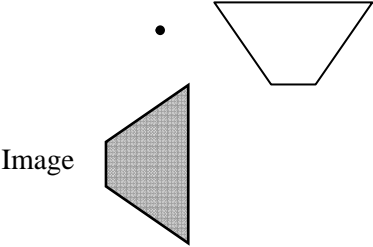
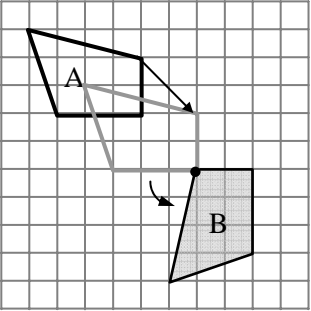
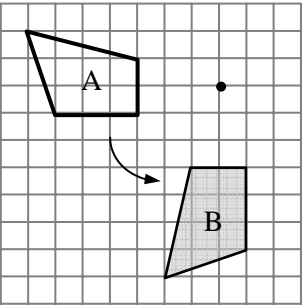
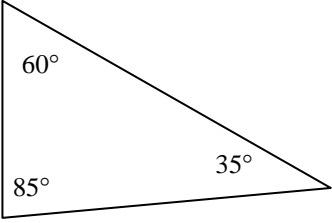
<p><b>1.</b></p>  <p><b>2. a)</b> 8; <i>Sample response:</i> It is a regular polygon with 8 sides.</p> <p><b>b)</b> 2; <i>Sample response:</i> The top and bottom sides are congruent, but no other side is that length.</p> <p><b>3. a)</b> <i>Sample response:</i> Translate A right 2 units and down 2 units, then rotate a <math>\frac{1}{4}</math> turn ccw around the turn centre shown.</p> 	<p><b>3. b)</b> Rotate a <math>\frac{1}{4}</math> turn ccw or a <math>\frac{3}{4}</math> turn cw around the turn centre shown.</p>  <p><b>4.</b> No; There are gaps, and a tessellation has no gaps.</p> <p><b>5.</b></p>  <p><b>6. a)</b> Yes; I measured both angles with a protractor to check that they were the same.</p> <p><b>b)</b> No; I can tell by looking at it that the bottom angle is larger than the top angle.</p>
---	---

## Answers [Continued]

7. *Sample response:*

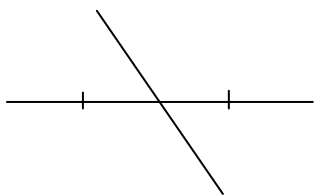

8. *Sample response:*

Different:

- An isosceles trapezoid has one pair of congruent triangles, plus two other triangles.
- A non-isosceles trapezoid has 4 non-congruent triangles.

Alike:

- Both divide the trapezoid into 4 triangles.

9. a) There are 6 vertical planes of symmetry. Each goes through the top vertex and one of these lines of symmetry of the hexagon base:

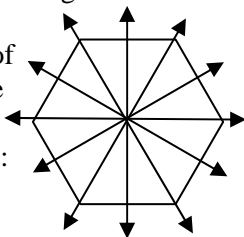

b) *Sample response:*

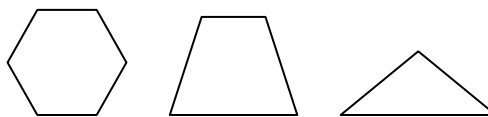

10. a) The back view matches the cube structure

b) The front view would match if I put a heavier line between the two bottom cubes to show the change of depth.

11. *Sample response:*

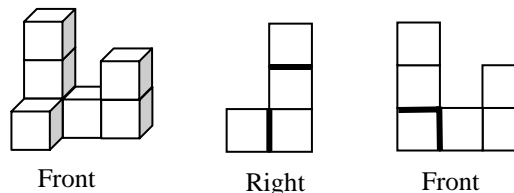

## UNIT 2 Assessment Interview

You may wish to interview selected students to assess their understanding of the work of this unit. The results can be used as formative assessment or as summative assessment data. As the students work, ask them to explain their thinking.

Have available grid paper, protractors, two copies each of several cut-out quadrilaterals from BLM 6 (but not the square or rectangle), and a cube structure made of 9 linking cubes that is not a prism.

Have the student choose one of the quadrilaterals and then ask:

- *Show how to rotate your quadrilateral a  $\frac{3}{4}$  turn cw. What clues can you use to tell you that you were right?*

Place two identical copies of the chosen quadrilateral on a grid and then ask:

- *How can you transform this quadrilateral to get to that quadrilateral? Can you do it in a single transformation or do you need to use more than one transformation?*
- *Does the quadrilateral you chose have rotational symmetry? How do you know? If it does not have rotational symmetry, show me a shape that does have rotational symmetry. How do you know it has rotational symmetry?*
- *Does your quadrilateral form a tessellation? Use the grid to show how you know.*
- *Measure one of the angles of your quadrilateral. Show how you would bisect that angle.*
- *Draw the diagonals of your quadrilateral. Are they perpendicular? Do they bisect each other?*

Show the student the cube structure and then ask:

- *Look at my cube structure. Does it have any planes of symmetry? How do you know?*
- *What does an orthographic drawing of the front view look like? How do you know?*
- *Can you create a different structure with the same front view but a different right view? How do you know the right views are different?*

## UNIT 2 Performance Task — Folding a Hexahedron

### Part 1 Use transformations to create a design

A. i) Copy this triangle and turn centre onto centimetre grid paper.

ii) Rotate the triangle a  $\frac{1}{4}$  turn ccw around the turn centre.

iii) Reflect the image from **part ii)** across its horizontal side.

iv) Rotate the image from **part iii)** a  $\frac{3}{4}$  turn ccw around the turn centre to complete your first design.

v) Describe a different way to transform the original triangle to create the same design.

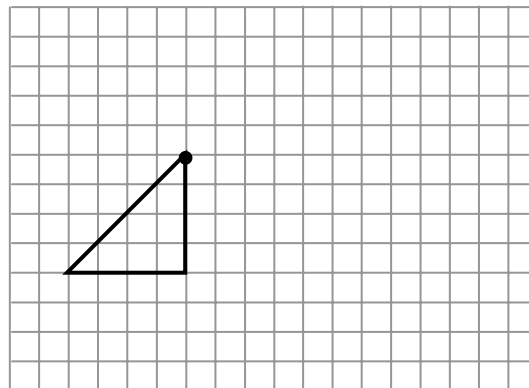

B. i) Locate the square in your design where one diagonal is showing.

- Mark the point on the diagonal where the other diagonal would cross it.
- How did you locate the point?

ii) Rotate the large triangle formed by the perimeter of your design from **part i)**  $180^\circ$  around the point you marked in **part i)**.

iii) Make three sketches of your new design from **part ii)**. For each feature listed below, mark examples on one sketch of the design:

- angle bisectors
- perpendicular bisectors
- non-perpendicular bisectors

### Part 2 Fold your design to make a 3-D shape

Cut out your design. Fold it to make creases along all the lines.

Follow these steps to fold it into a 3-D shape called a hexahedron:

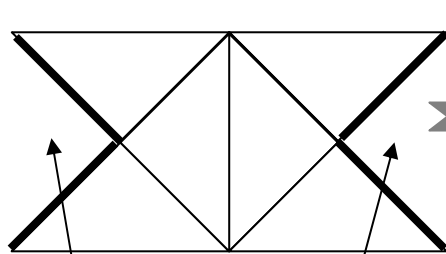

Tape the marked sides together at each end.

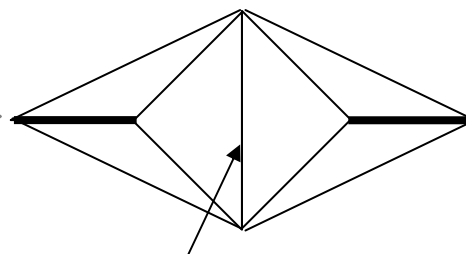

Fold along the diagonal of the square until the untaped sides meet. Tape them together.

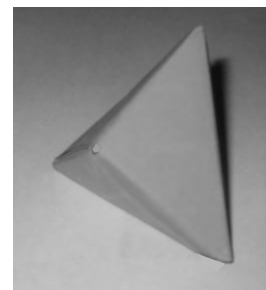

C. i) Sketch or describe the planes of symmetry of your hexahedron.

ii) Sketch or describe two or more cross sections of your hexahedron.

## UNIT 2 Performance Task

Curriculum Outcomes Assessed	Pacing	Materials
<b>6-E1</b> Rotations: $\frac{1}{4}$ ( $90^\circ$ ), $\frac{1}{2}$ ( $180^\circ$ ), and $\frac{3}{4}$ turns <b>6-E4</b> Combining Transformations: predict and confirm results <b>6-E6</b> Bisectors: angles and line segments <b>6-E7</b> Quadrilaterals: sort by attributes <b>6-E9</b> Planes of Symmetry: 3-D shapes <b>6-E10</b> Cross Sections: cones, cylinders, prisms, and pyramids	1 h	<ul style="list-style-type: none"> <li>• Grid paper (1 cm by 1 cm) (BLM)</li> <li>• Rulers</li> <li>• Scissors</li> </ul>

### How to Use This Performance Task

- You might use this task as a rich problem to assess student understanding of a number of outcomes in this unit. It could replace or supplement the unit test. It could also be used as enrichment material for some students.
- You can assess performance on the task using the rubric provided or on the next page.

### Sample Solution

A.

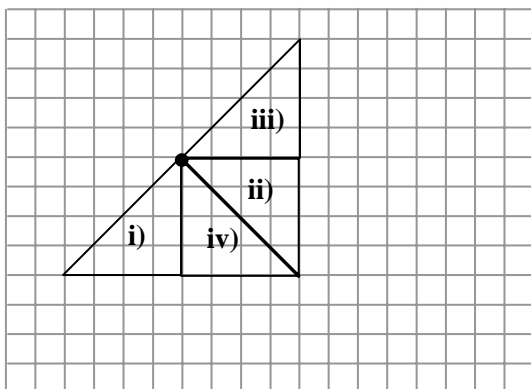

- v) Reflect in the vertical side, rotate that image a  $\frac{1}{4}$  turn ccw around the turn centre, then reflect that image in its horizontal side.

B. i) I know that the other diagonal bisects it, so I marked the point halfway along the diagonal.

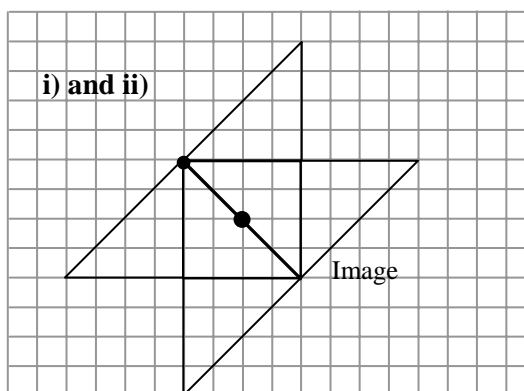

iii)

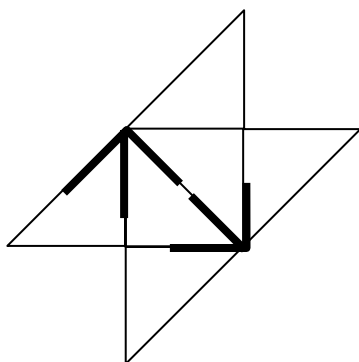

Angle bisectors

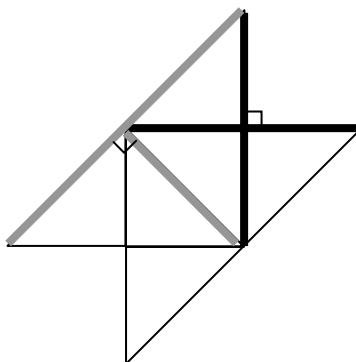

Perpendicular bisectors

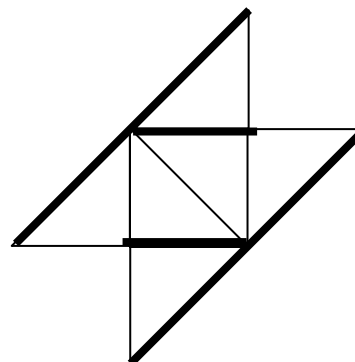

Non-perpendicular bisectors

C. i) Planes of symmetry cut along the lines shown when you look straight on at the hexahedron.

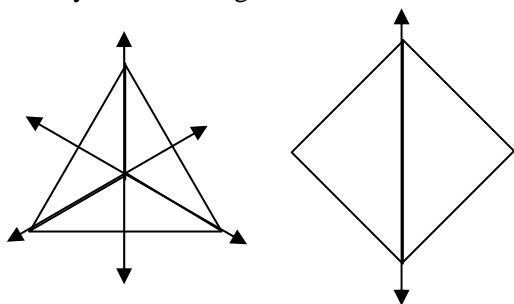

ii)

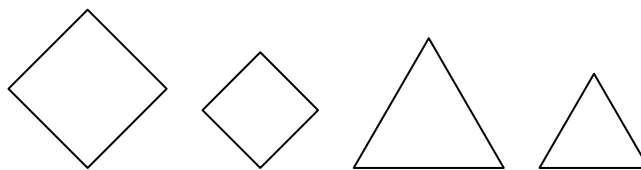

### UNIT 2 Performance Task Assessment Rubric

<i>The student</i>	<b>Level 4</b>	<b>Level 3</b>	<b>Level 2</b>	<b>Level 1</b>
<b>Performs transformations</b>	Performs completely accurate transformations	Performs reasonably accurate transformations (errors do not suggest misconceptions)	Performs reasonably accurate transformations for most of the design	Shows major errors in transformations
<b>Describes a combination of transformations</b>	Provides a completely accurate and insightful description	Provides a reasonably accurate description (errors do not suggest misconceptions)	Provides a reasonably accurate description for most of the design	Shows major errors in the description
<b>Identifies property of diagonals of a square and explains thinking</b>	Identifies properties accurately and provides thorough explanation	Identifies properties accurately and provides reasonable explanation	Identifies properties accurately but with minimal explanation	Shows major flaws in identifying properties or in explaining thinking
<b>Identifies bisectors</b>	Identifies bisectors accurately and completely	Identifies bisectors reasonably accurately with no major errors	Identifies bisectors reasonably accurately with some errors	Shows major flaws in identifying bisectors
<b>Sketches or describes planes of symmetry and cross-sections</b>	Sketches or describes accurately and completely	Sketches or describes reasonably accurately with no major errors	Sketches or describes reasonably accurately with some errors	Shows major errors in sketches or description

# UNIT 2 Blackline Masters

## BLM 1 Tessellating Shapes

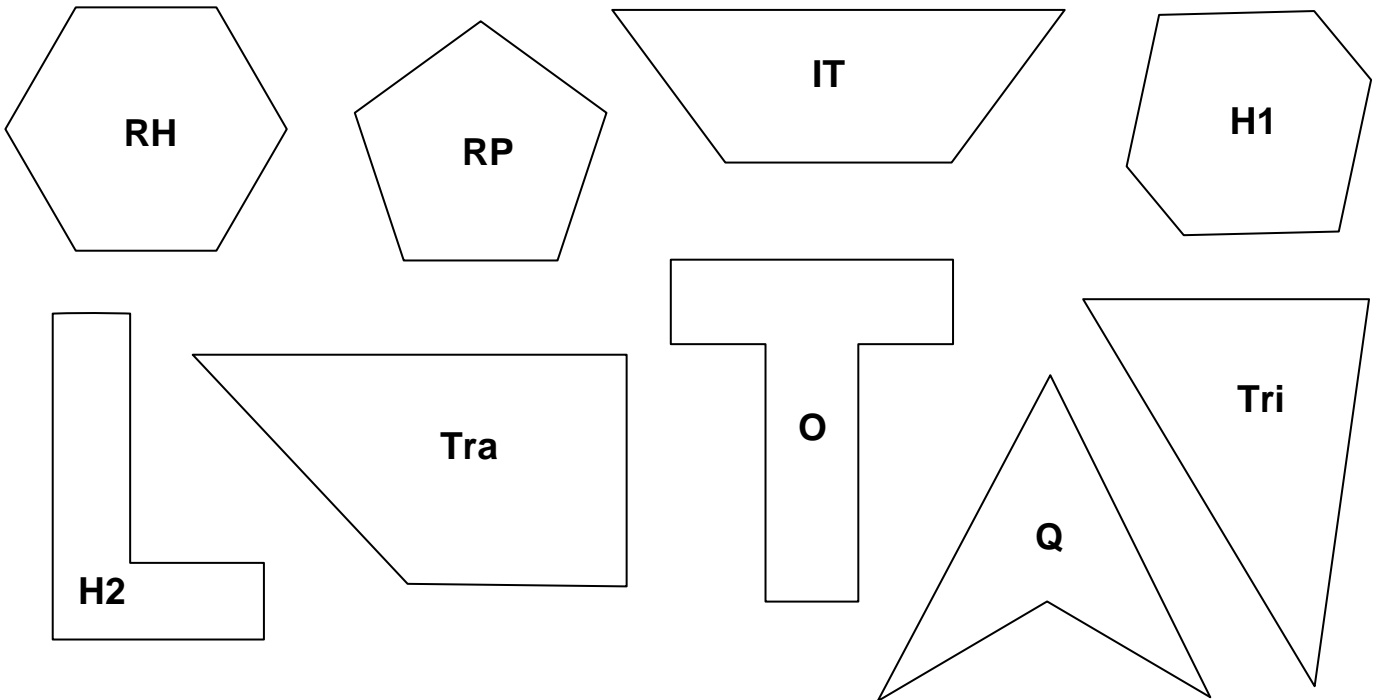
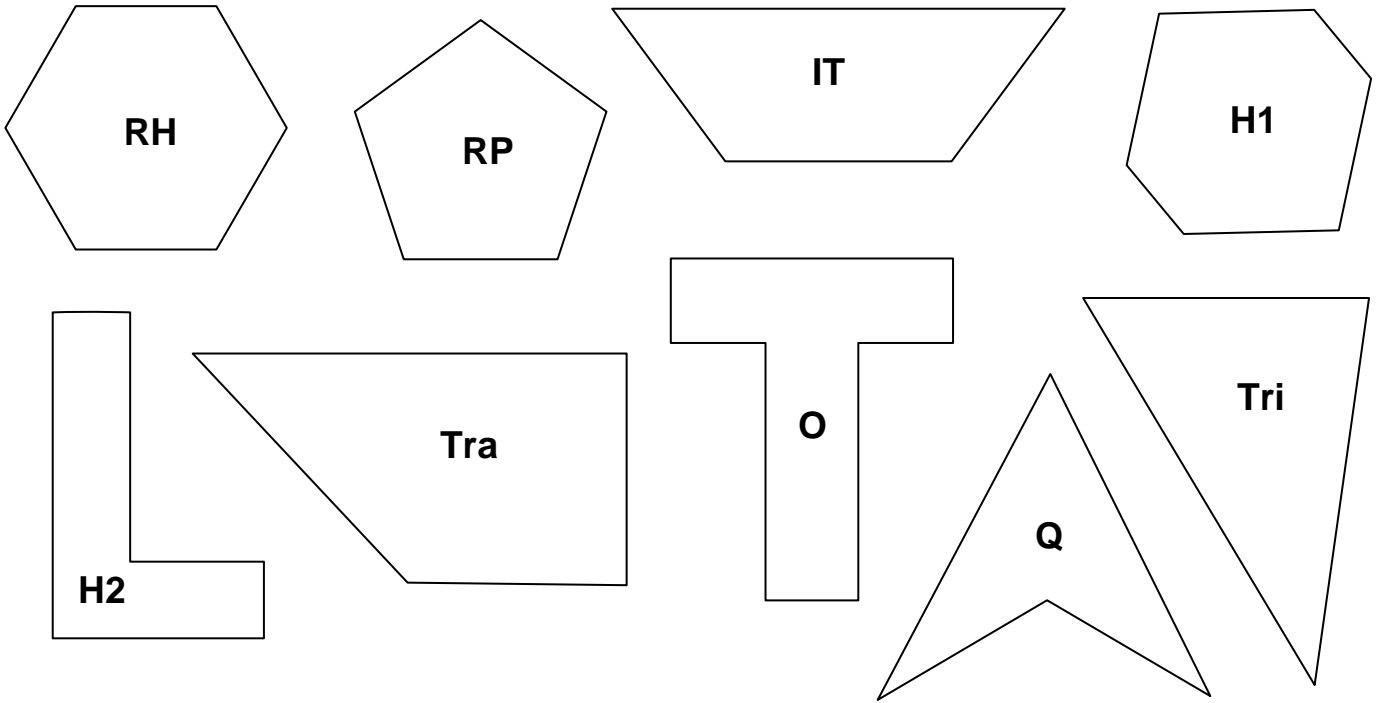

## BLM 2 Paper Protractors

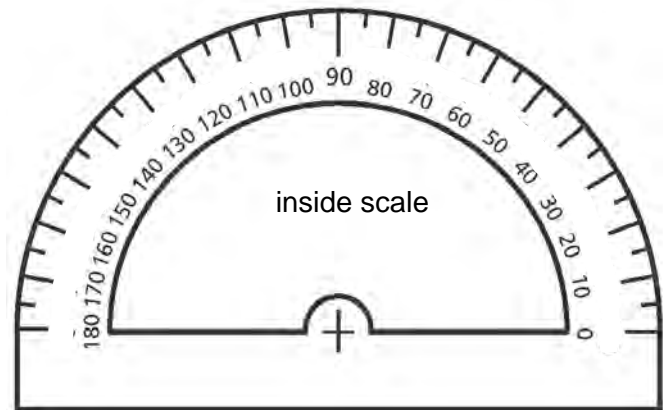
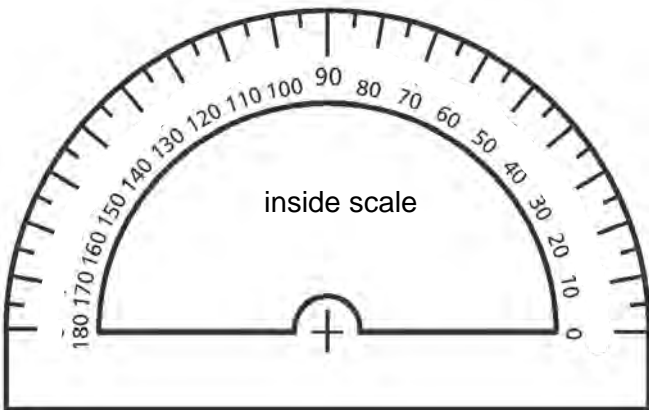
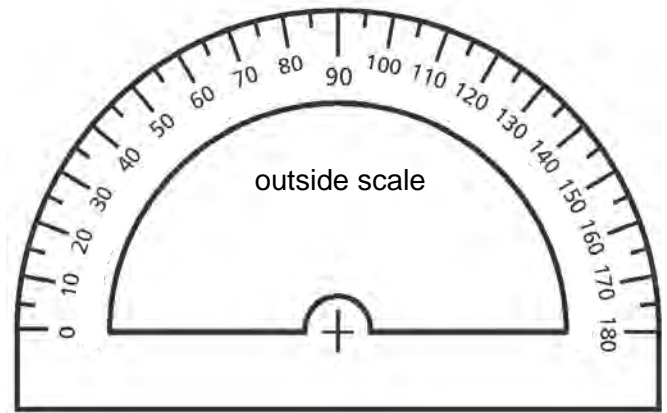
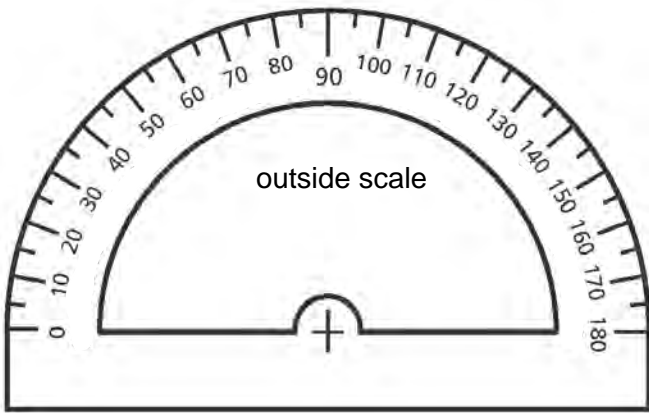
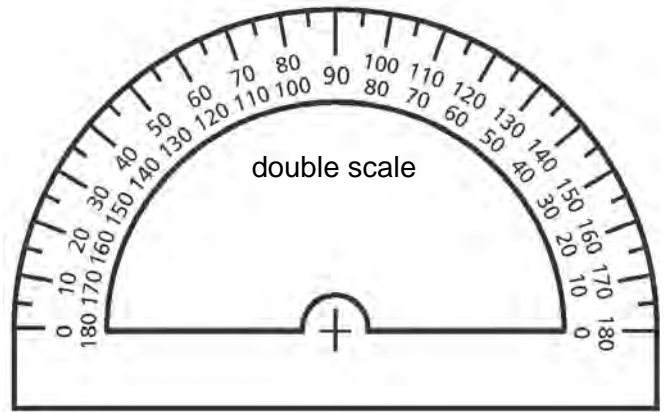
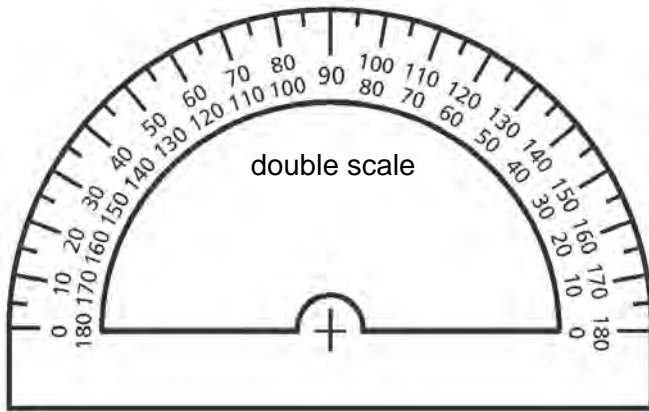
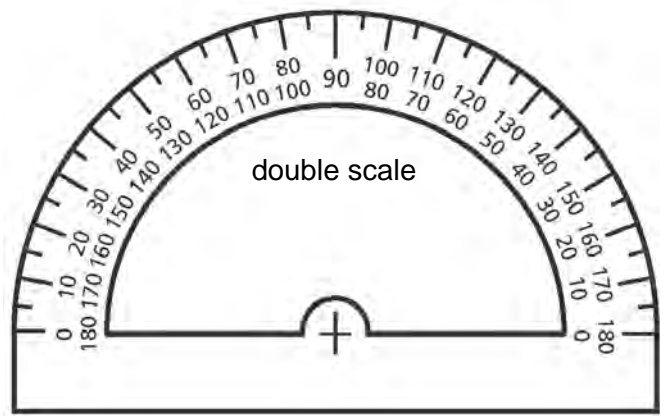
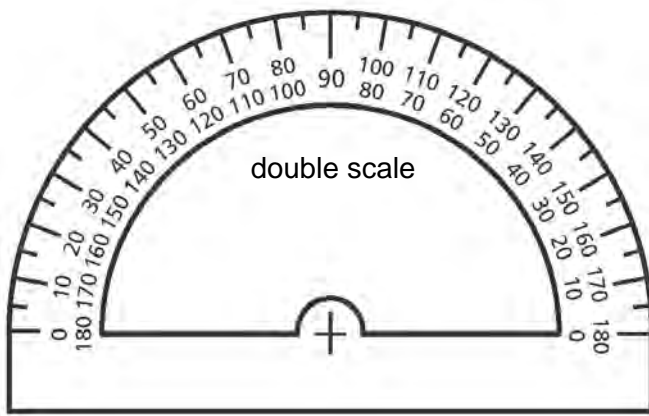



### BLM 3 Field Angles



**BLM 4 Angle Bisectors**

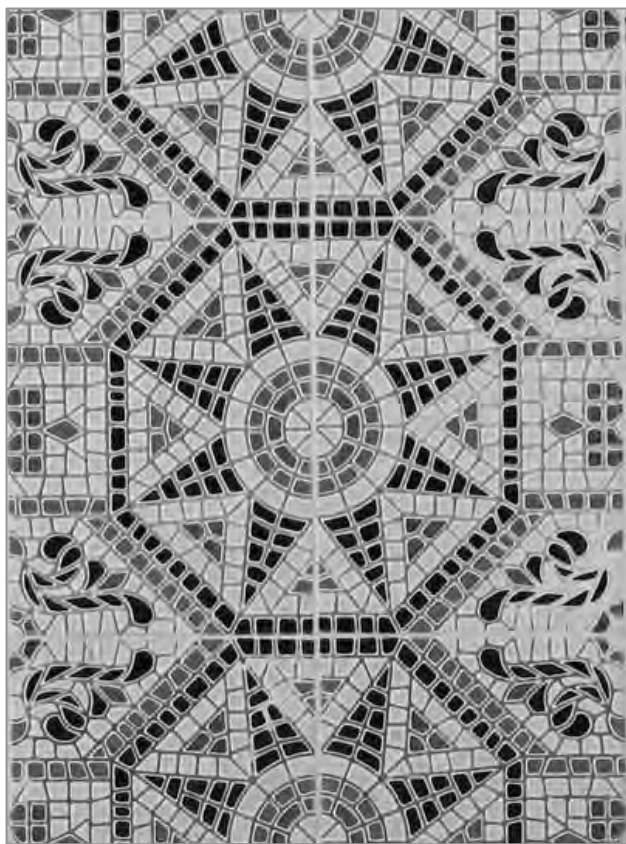
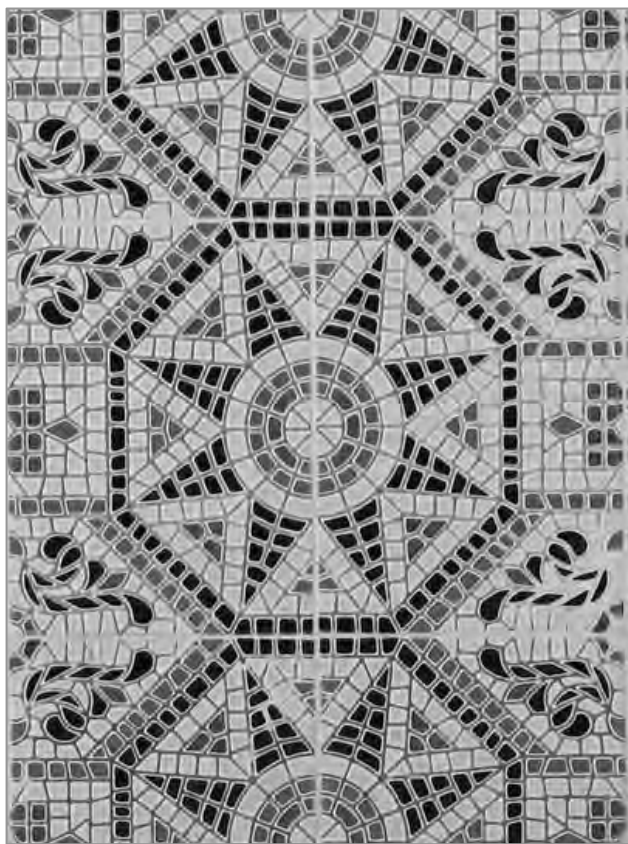
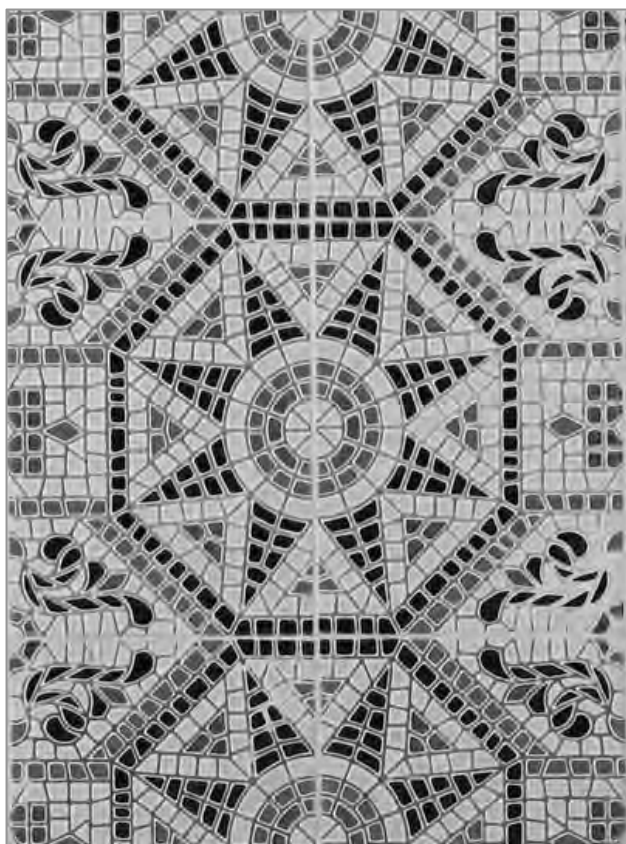
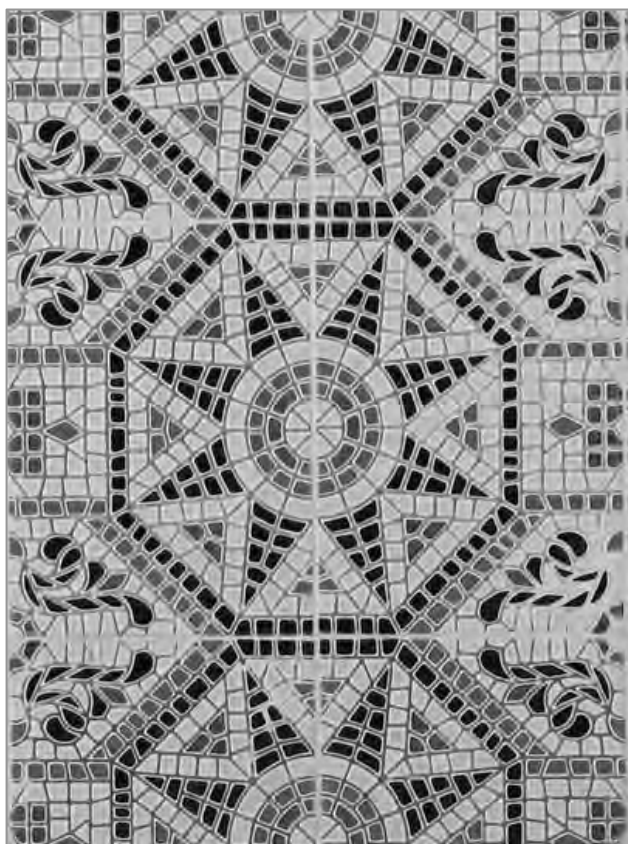

# BLM 5 Sorting Quadrilaterals

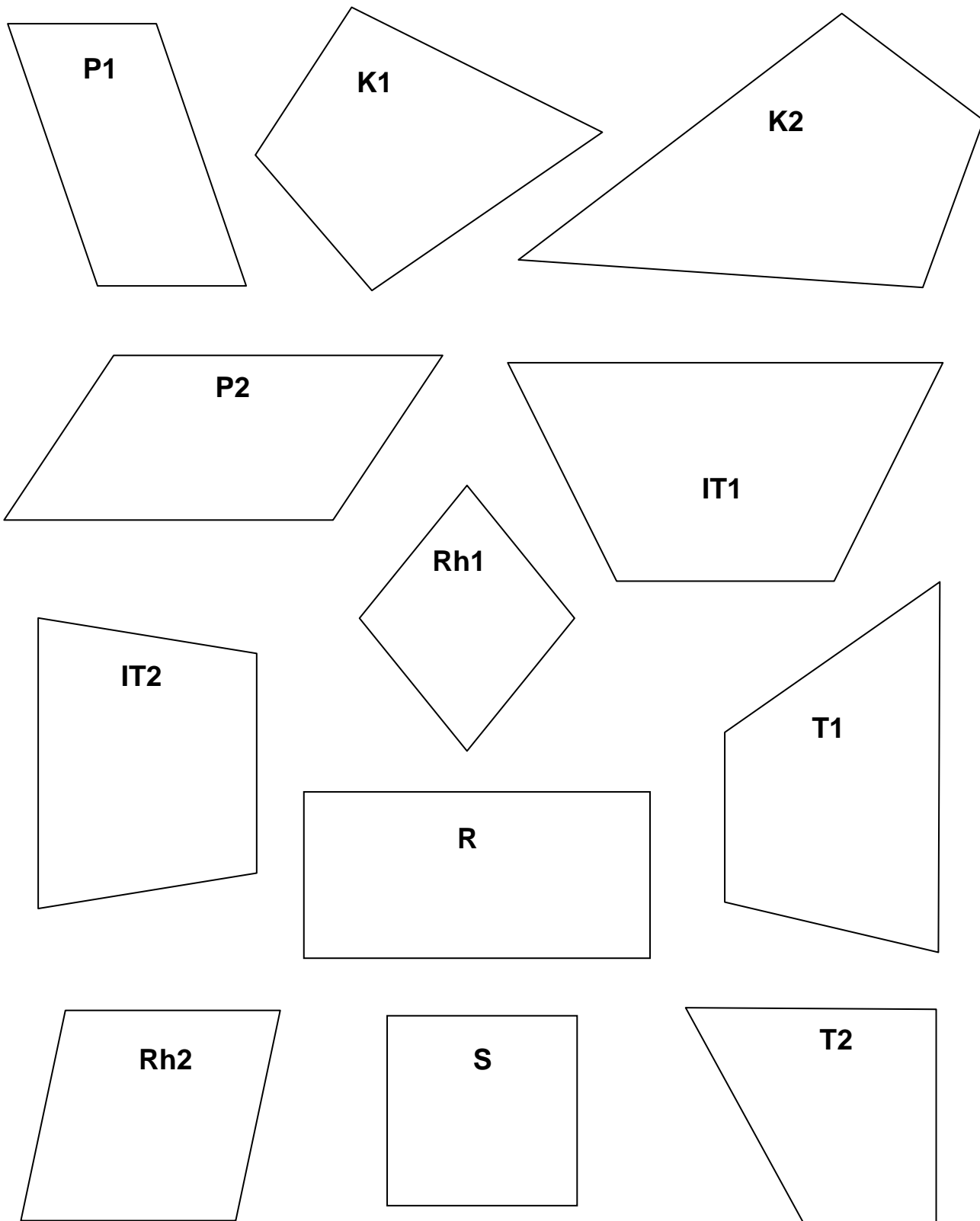

**BLM 6 Go Fish Game Cards**

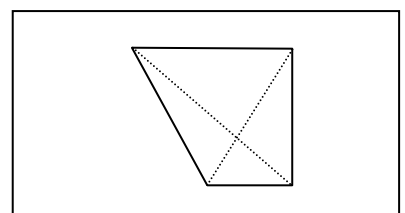
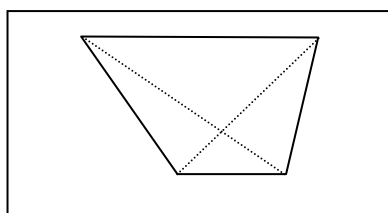
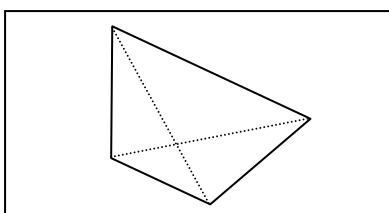
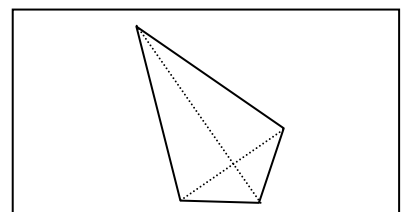
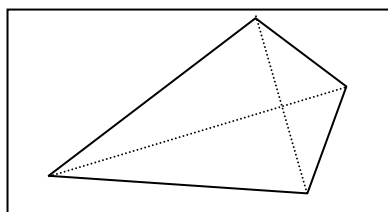
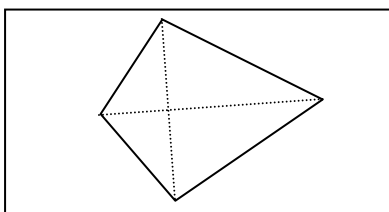
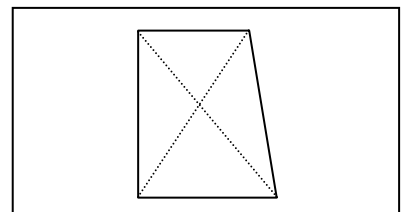
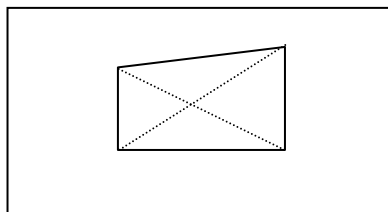
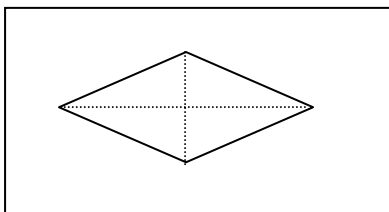
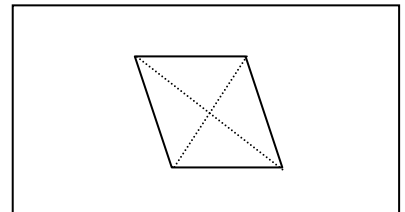
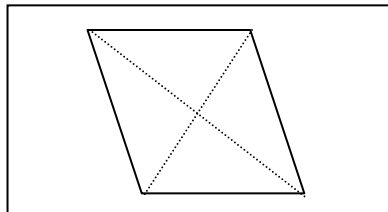
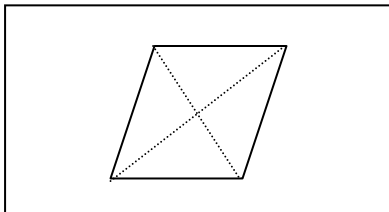
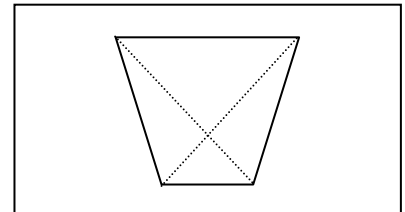
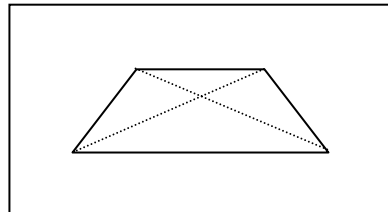
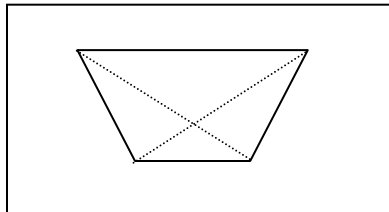
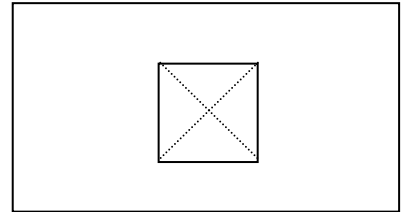
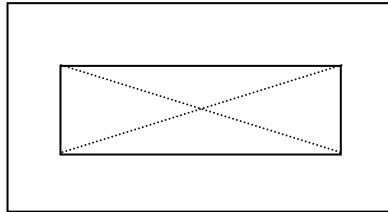
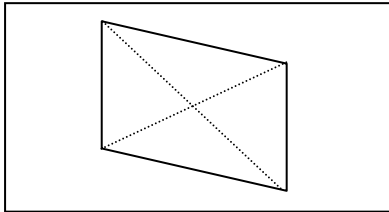
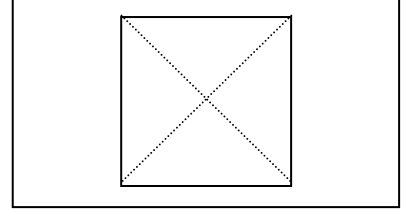
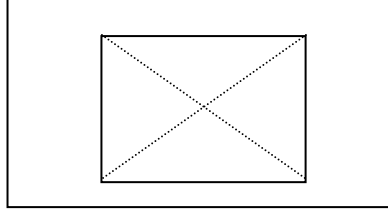
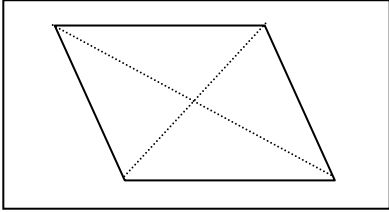
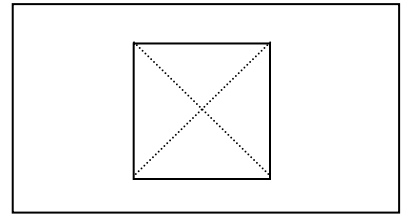
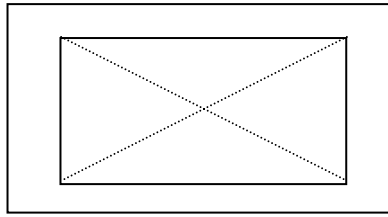
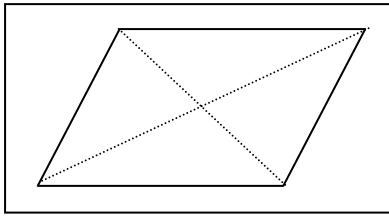

**BLM 7 Sample Net of Cube**

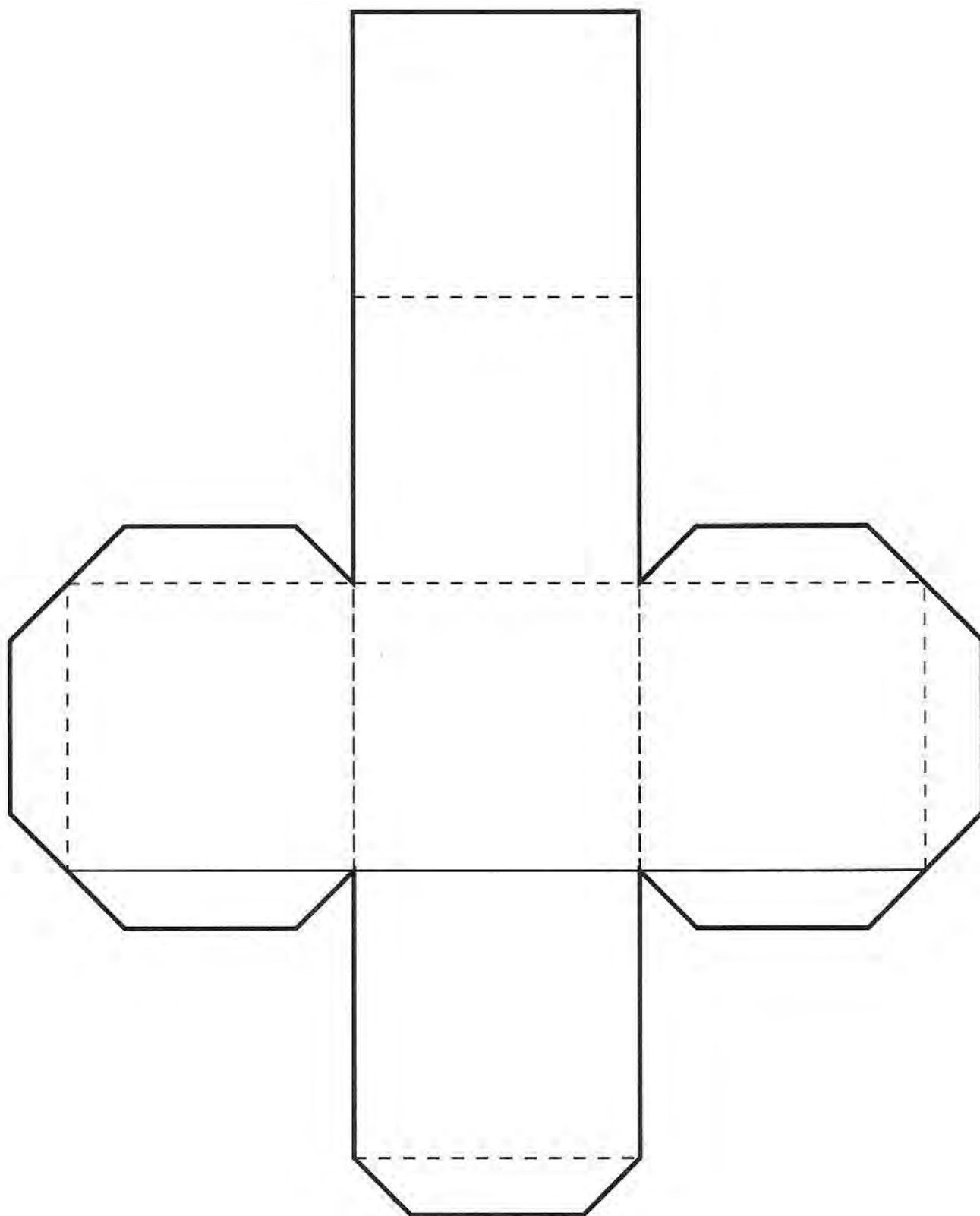

**BLM 8 Sample Net of Right Triangle-based Prism**

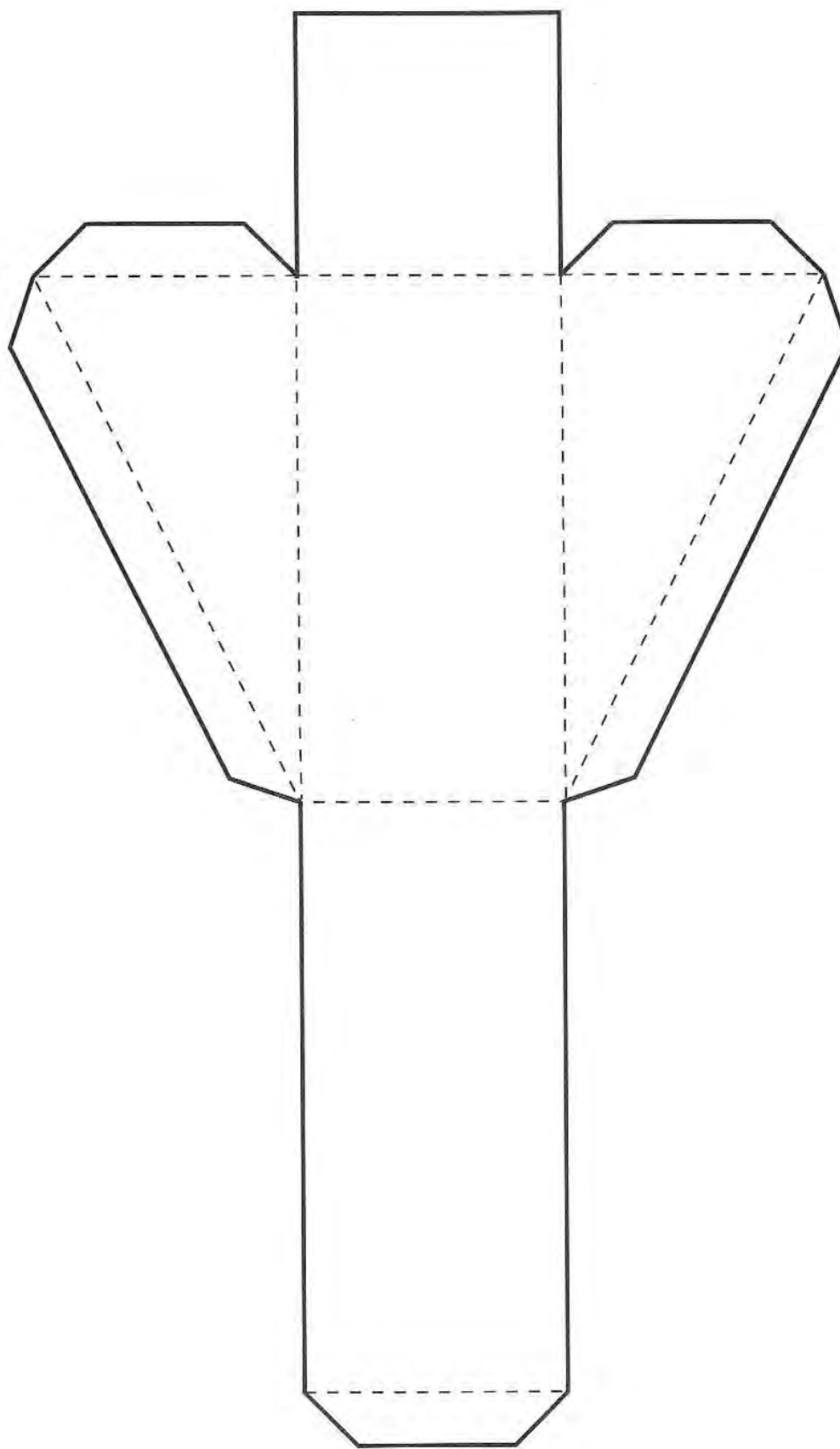

**BLM 9 Sample Net of Rectangle-based Prism**

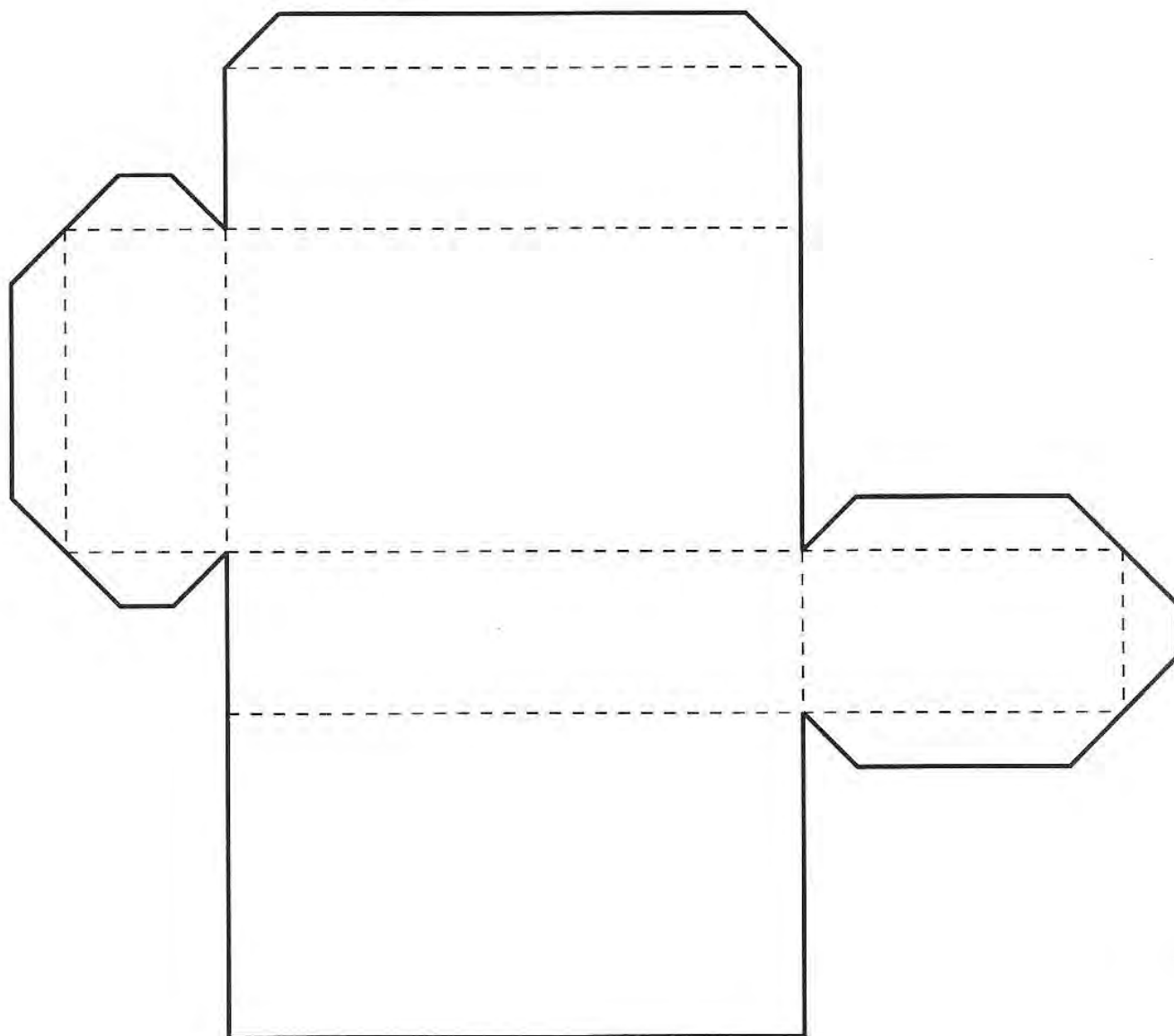

**BLM 10 Sample Net of Square-based Pyramid**

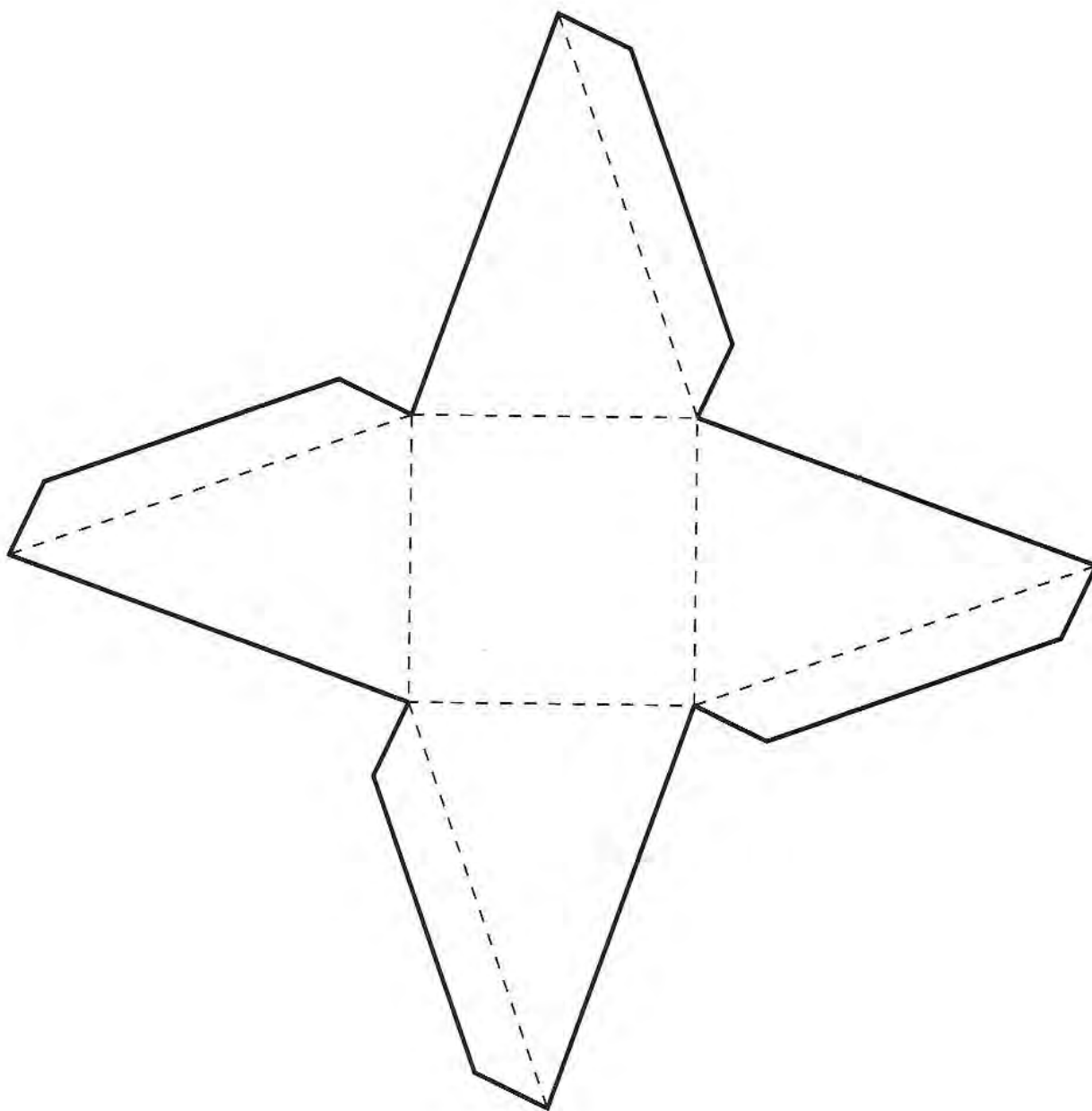



**BLM 11 Sample Net of Regular Hexagon-based Prism**

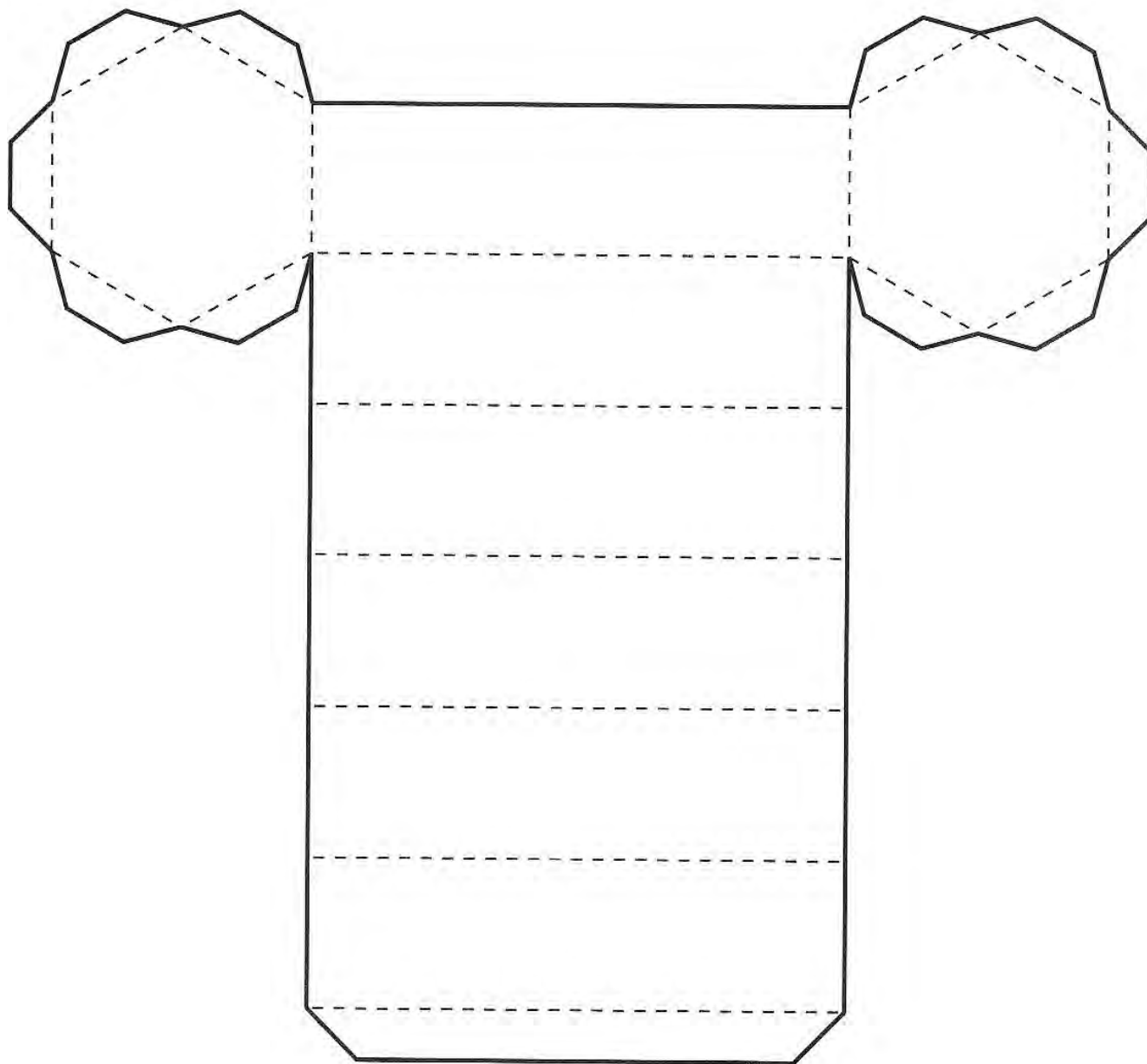

**BLM 12 Grid Paper (1 cm by 1 cm)**

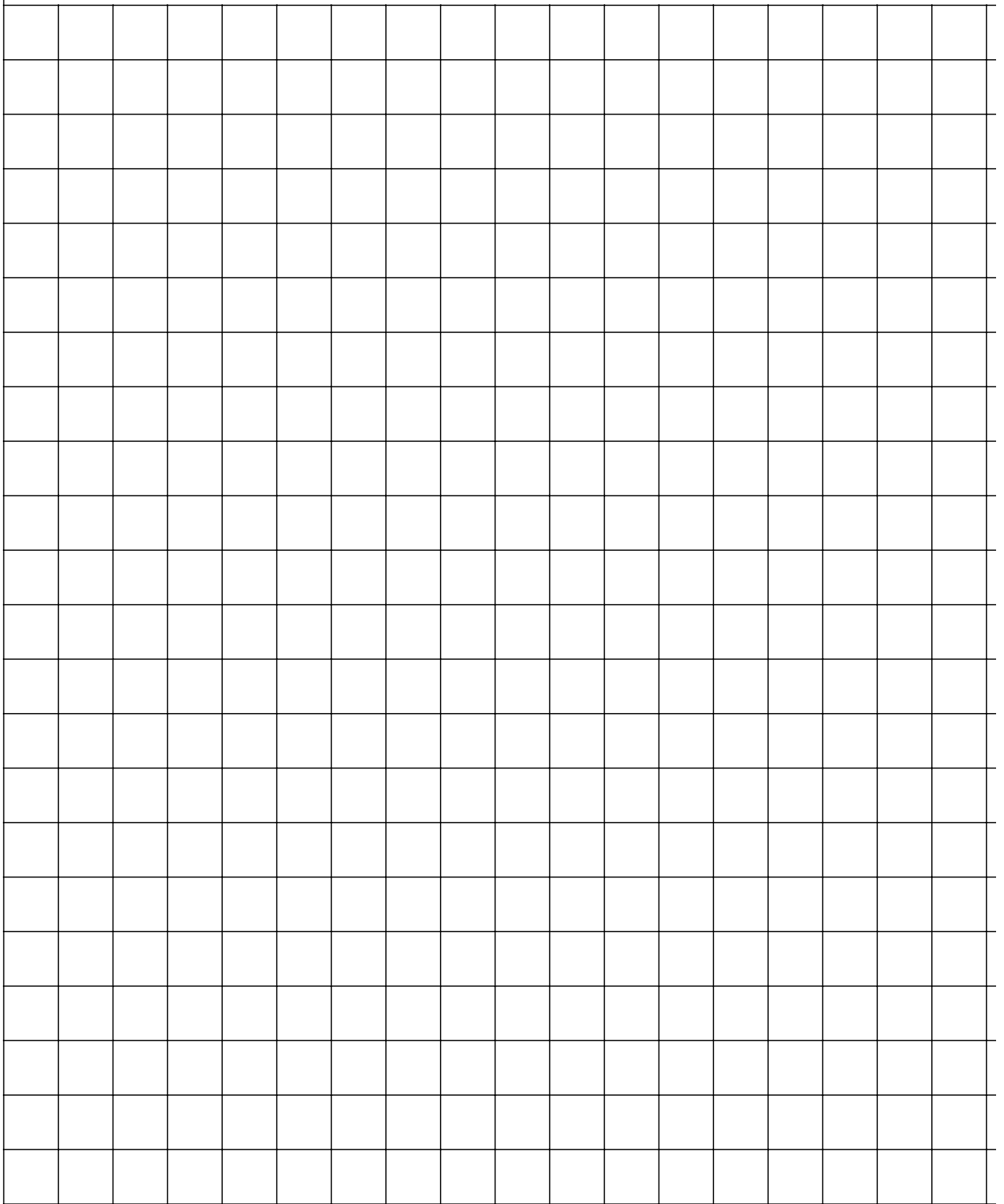

# UNIT 3 DECIMAL COMPUTATION

## UNIT 3 PLANNING CHART

	Outcomes or Purpose	Suggested Pacing	Materials	Suggested Assessment
Getting Started SB p. 69 TG p. 108	Review prerequisite concepts, skills, and terminology and pre-assessment	1 h	<ul style="list-style-type: none"> <li>Place Value Charts I (BLM) (optional)</li> <li>Base Ten Models 2A and 2B (BLM) (optional)</li> </ul>	All questions
<b>Chapter 1 Multiplication</b>				
3.1.1 Estimating a Product SB p. 71 TG p. 111	<b>6-B2 Estimation Strategies for Multiplication and Division: whole numbers and decimals</b> <ul style="list-style-type: none"> <li>apply estimation strategies: rounding, front-end</li> </ul>	1 h	None	Q2, 6, 7
3.1.2 Multiplying a Decimal by a Whole Number SB p. 73 TG p. 113	<b>6-B3 Multiply Decimals by Whole Numbers: pictorially, symbolically</b> <ul style="list-style-type: none"> <li>compute products of whole numbers using an algorithm</li> <li>know when to use a pencil/paper algorithm or a mental procedure</li> <li>regularly estimate when performing computations</li> </ul> <b>6-B2 Estimation Strategies for Multiplication and Division: whole numbers and decimals</b> <ul style="list-style-type: none"> <li>apply estimation strategies: rounding, front-end</li> </ul> <b>6-C1 Linear Equations: using open frames</b> <ul style="list-style-type: none"> <li>solve simple linear open frame equations in context (e.g., 23 students, 8 are absent; others are sitting in groups of 3. How many groups? <math>3 \times \square + 8 = 23</math>)</li> <li>replace open frames with letters</li> </ul>	1 h	<ul style="list-style-type: none"> <li>Place Value Charts I (BLM)</li> </ul>	Q1, 5, 6, 9
3.1.3 Multiplying Decimals SB p. 77 TG p. 116	<b>6-B4 Multiply Decimals by Decimals: concretely and symbolically</b> <ul style="list-style-type: none"> <li>use meaningful strategies to calculate products of decimals</li> <li>regularly estimate when performing computations</li> </ul> <b>6-B2 Estimation Strategies for Multiplication and Division: whole numbers and decimals</b> <ul style="list-style-type: none"> <li>apply estimation strategies: rounding, front-end</li> </ul>	1.5 h	<ul style="list-style-type: none"> <li>Hundredths Grids (BLM)</li> <li>Place Value Charts I (BLM)</li> </ul>	Q1, 3, 5, 8
GAME: Target 10 (Optional) SB p. 81 TG p. 119	Practise decimal multiplication in a game situation	20 min	<ul style="list-style-type: none"> <li>Dice</li> </ul>	N/A

## UNIT 3 PLANNING CHART [Continued]

	Outcomes or Purpose	Suggested Pacing	Materials	Suggested Assessment
<b>Chapter 2 Division</b>				
<b>3.2.1</b> Estimating a Quotient <b>SB p. 82</b> <b>TG p. 120</b>	<b>6-B2 Estimation Strategies for Multiplication and Division: whole numbers and decimals</b> • apply estimation strategies: rounding, front-end	1 h	None	Q1, 6, 7
<b>3.2.2</b> Dividing a Decimal by a Whole Number <b>SB p. 84</b> <b>TG p. 123</b>	<b>6-B5 Whole Numbers and Decimals: single-digit division</b> • relate to whole number division • link concrete models to algorithms • regularly estimate when performing computations <b>6-B2 Estimation Strategies for Multiplication and Division: whole numbers and decimals</b> • apply estimation strategies: rounding, front-end	1 h	None	Q1, 3, 6
<b>3.2.3 EXPLORE:</b> Dividing by 0.1, 0.01, and 0.001 (Essential) <b>SB p. 87</b> <b>TG p. 125</b>	<b>6-B6 Divide Mentally: whole numbers by 0.1, 0.01, 0.001</b> • recognize the pattern of changes produced by dividing by 0.1, 0.01, 0.001 is the same as that produced by multiplying by 10, 100, 1000 • describe these patterns in terms of place value changes	40 min	None	Observe and Assess questions
<b>3.2.4</b> Dividing Decimals <b>SB p. 88</b> <b>TG p. 127</b>	<b>6-B2 Estimation Strategies for Multiplication and Division: whole numbers and decimals</b> • apply estimation strategies: rounding, front-end <b>6-B7 Divide Decimals by Decimals: estimating and developing algorithms through reasoning</b> • use meaningful strategies to calculate quotients of decimals	1.5 h	• Hundredths Grids (BLM)	Q2, 5, 9
<b>Chapter 3 Combining Operations</b>				
<b>3.3.1</b> Order of Operations <b>SB p. 91</b> <b>TG p. 131</b>	<b>6-B8 Addition and Subtraction of Decimals and Whole numbers: choosing most appropriate method</b> • choose among written, mental calculations, estimation as the most appropriate method • regularly estimate when performing computations • apply strategies: front-end estimation, compensation (e.g., $14.95 + 1.99 + 10.98 - 7.1 = 15 + 2 + 11 - 8 = 20$ ) <b>6-B3 Multiply Decimals by Whole Numbers: pictorially, symbolically</b> • compute products of whole numbers using an algorithm • know when to use a pencil/paper algorithm or a mental procedure • regularly estimate when performing computations	1 h	None	Q1, 3, 4

	<b>Outcomes or Purpose</b>	<b>Suggested Pacing</b>	<b>Materials</b>	<b>Suggested Assessment</b>
	<p><b>6-B4 Multiply Decimals by Decimals: concretely and symbolically</b></p> <ul style="list-style-type: none"> <li>• use meaningful strategies to calculate products of decimals</li> <li>• regularly estimate when performing computations</li> </ul> <p><b>6-B5 Whole Numbers and Decimals: single-digit division</b></p> <ul style="list-style-type: none"> <li>• relate to whole number division</li> <li>• link concrete models to algorithms</li> <li>• regularly estimate when performing computations</li> </ul> <p><b>6-B7 Divide Decimals by Decimals: estimating and developing algorithms through reasoning</b></p> <ul style="list-style-type: none"> <li>• use meaningful strategies to calculate quotients of decimals</li> </ul>			
<p><b>3.3.2 Solving a Problem Using all Four Operations</b>  <b>SB p. 93</b>  <b>TG p. 134</b></p>	<p><b>6-B8 Addition and Subtraction of Decimals and Whole numbers: choosing most appropriate method</b></p> <ul style="list-style-type: none"> <li>• choose among written, mental calculations, estimation as the most appropriate method</li> <li>• regularly estimate when performing computations</li> <li>• apply strategies: front-end estimation, compensation (e.g., <math>14.95 + 1.99 + 10.98 - 7.1 = 15 + 2 + 11 - 8 = 20</math>)</li> </ul> <p><b>6-B3 Multiply Decimals by Whole Numbers: pictorially, symbolically</b></p> <ul style="list-style-type: none"> <li>• compute products of whole numbers using an algorithm</li> <li>• know when to use a pencil/paper algorithm or a mental procedure</li> <li>• regularly estimate when performing computations</li> </ul> <p><b>6-B4 Multiply Decimals by Decimals: concretely and symbolically</b></p> <ul style="list-style-type: none"> <li>• use meaningful strategies to calculate products of decimals</li> <li>• regularly estimate when performing computations</li> </ul> <p><b>6-B5 Whole Numbers and Decimals: single-digit division</b></p> <ul style="list-style-type: none"> <li>• relate to whole number division</li> <li>• link concrete models to algorithms</li> <li>• regularly estimate when performing computations</li> </ul> <p><b>6-B7 Divide Decimals by Decimals: estimating and developing algorithms through reasoning</b></p> <ul style="list-style-type: none"> <li>• use meaningful strategies to calculate quotients of decimals</li> </ul>	1 h	None	Q2, 3, 5
<p><b>CONNECTIONS:</b>  <b>Decimal Magic Squares (Optional)</b>  <b>SB p. 95</b>  <b>TG p. 136</b></p>	<p>Make a connection between properties of whole numbers and properties of decimal numbers</p>	20 min	None	N/A

## UNIT 3 PLANNING CHART [Continued]

	<b>Outcomes or Purpose</b>	<b>Suggested Pacing</b>	<b>Materials</b>	<b>Suggested Assessment</b>
UNIT 3 Revision <b>SB p. 96</b> <b>TG p. 137</b>	Review the concepts and skills in the unit	2 h	<ul style="list-style-type: none"> <li>• Place Value Charts I (BLM)</li> <li>• Hundredths Grids (BLM) (optional)</li> </ul>	All questions
UNIT 3 Test <b>TG p. 139</b>	Assess the concepts and skills in the unit	1 h	<ul style="list-style-type: none"> <li>• Place Value Charts I (BLM)</li> <li>• Hundredths Grids (BLM) (optional)</li> </ul>	All questions
UNIT 3 Performance Task <b>TG p. 142</b>	Assess concepts and skills in the unit	1 h	<ul style="list-style-type: none"> <li>• Hundredths Grids (BLM) (optional)</li> <li>• Place Value Charts I (BLM) (optional)</li> </ul>	Rubric provided
UNIT 3 Blackline Masters <b>TG p. 144</b>	BLM 1 Place Value Charts I (the tens place to the thousandths place) BLM 2A Base Ten Models (hundreds, tens, and ones) BLM 2B Base Ten Models (thousands) Hundredths Grids in Unit 1 on <b>page 37</b>			

## Math Background

- Decimal multiplication and division are a logical extension of earlier work with whole number multiplication and division. These skills are important and useful in day-to-day life.
- The work in the unit assumes that students already have the ability to add and subtract decimals and to interpret them.
- As students proceed through this unit they will use a variety of mathematical processes, including problem solving, communication, reasoning, representation, visualization, and making connections.

For example:

- Students use problem solving in **question 1** in **lesson 3.1.1**, where they estimate ages, in **question 6** in **lesson 3.1.2**, where they solve a problem involving a recipe, in **question 7** in **lesson 3.1.3**, where they solve a puzzle by filling in digits in the appropriate places, in **question 3** in **lesson 3.2.4**, where they solve a real-world problem using decimal division, and throughout **lesson 3.3.2**.
- Students use communication in **question 7** in **lesson 3.1.1**, where they describe a situation that requires an estimate, in **question 10** in **lesson 3.1.2**, where they compare decimal multiplication with whole number multiplication, and in **question 8** in **lesson 3.2.4**, where they respond to a mistake in a calculation and explain the error.
- Students use reasoning in answering questions such as **question 4** in **lesson 3.1.1**, where they reason about what values would lead to a given estimate, in **question 4** in **lesson 3.1.2**, where they predict what digit will be in the tenths place after a particular calculation, in **question 5** in **lesson 3.2.1**, where they select digits to make a statement true, in **lesson 3.2.3**, where they use patterns to make sense of unfamiliar decimal calculations, and in **question 4** in **lesson 3.3.1**, when they decide whether brackets are necessary for particular computations.
- Students consider representation in **lesson 3.1.2**, where they see the value of a place value chart to keep track of a complex calculation, in the interpretation of multiplication used in **lesson 3.1.3**, and in the **Try This** in **lesson 3.2.2**, where they use a diagram to help them recognize what they need to calculate.

- Students use visualization skills in **lesson 3.1.3**, where they use hundredths grids to visualize the product of two decimals less than 1, in **question 6** in **lesson 3.2.2**, where a diagram can help them solve a problem, and in **lesson 3.2.4**, where they use grids to visualize decimal quotients.
- Students make connections in **lesson 3.1.3**, where they relate decimal multiplication to whole number multiplication, in **question 11** in **lesson 3.1.3**, where they explore a real-world connection to a person's height at different ages, and in **question 2** in **lesson 3.2.1** and **question 5** in **lesson 3.2.2**, where they see the usefulness of decimal division in calculating measurements.

## Rationale for Teaching Approach

- This unit is divided into three chapters:  
**Chapter 1** focuses on decimal multiplication.  
**Chapter 2** focuses on decimal division.  
**Chapter 3** focuses on the combining of all four decimal operations, both in calculations and to solve problems.
- The **Explore** lesson allows students to use their understanding of patterns to help them develop rules for dividing by decimal powers of ten.
- The **Connections** section allows students to practice decimal computation skills in the context of a Magic Square problem. They see how number properties that apply to whole numbers also apply to decimals.
- The **Game** provides an opportunity for students to practice estimating and calculating decimal products.
- Throughout the unit, the focus is on developing meaning and not on just learning rules. It is important for students to recognize the value in doing this and to be encouraged to use a variety of strategies in their calculations.

## Getting Started

Curriculum Outcomes	Outcome relevance
<p>4 Dimensions and Area; Factors and Products (rectangles): relate</p> <p>5 Addition and Subtraction of Decimals and Wholes: 5 digits to 100ths</p> <p>5 2-Digit <math>\times</math> 2-Digit Multiplication: with / without regrouping</p> <p>5 Decimals <math>\times</math> Whole Numbers: simple products</p> <p>5 4-Digit <math>\div</math> 1-Digit: with/without regrouping</p> <p>5 4-Digit <math>\div</math> 2-Digit: introduce</p> <p>5 Multiply Mentally: to 4 digits <math>\times</math> 1 digit</p> <p>5 Divide Mentally</p> <p>5 Perimeter: polygons</p>	<p>To be successful with decimal multiplication and division, students need to recall how to multiply and divide whole numbers and how to add and subtract decimals.</p>

Pacing	Materials	Prerequisites
1 h	<ul style="list-style-type: none"> <li>Place Value Charts I (BLM) (optional)</li> <li>Base Ten Models 2A and 2B (BLM) (optional)</li> </ul>	<ul style="list-style-type: none"> <li>multiplying 2-digit whole numbers</li> <li>multiplying and dividing by 10 using mental math</li> <li>multiplying a 4-digit number by a 1-digit number</li> <li>estimating products of whole numbers and decimals</li> <li>dividing by 10, 100, or 1000 using mental math</li> <li>dividing a 4-digit number by a 1-digit number and by 2-digit multiples of 10</li> <li>calculating the perimeter of a triangle and the area of a rectangle</li> </ul>

### Main Points to be Raised

#### *Use What You Know*

- To multiply a 3-digit whole number by a 1-digit whole number, you can multiply each part of the 3-digit number and then add the parts.
- To divide a whole number by a second number, you can calculate how many groups of the second number fit into the first number.
- You might need to use many operations to solve a problem.

#### *Skills You Will Need*

- To estimate a product or a quotient, you might round one or both value(s) to an appropriate multiple of 10 or 100.
- You can often use mental math to multiply and divide when one of the numbers is a multiple of 10 or 100.
- You can model the product of two 2-digit numbers by calculating and adding four partial products displayed in an area diagram.
- You can model multiplication using base ten blocks and place value charts.
- To multiply a 4-digit number by a 1-digit number, you can multiply each part of the 4-digit number and then add the partial products.
- You can multiply a decimal by a single digit number much like you would multiply a whole number by that single digit number, keeping in mind the place values.
- To divide by 10, 100, or 1000, you can move digits the required number of places.
- To divide a 4-digit number by a 1-digit number, you can divide the 4-digit number in parts and then add the parts.
- To divide by a multiple of 10, you can divide by the multiple and then by 10, in either order.
- To add means to accumulate different values. To multiply means to accumulate the same value over and over.
- Division is the inverse, reverse, or opposite of multiplication.



## Use What You Know — Introducing the Unit

- Before assigning the activity, read through the information at the top of **page 69** of the student text with your students. Encourage students to write the information in a chart or in simple outline form.

For example:

Total fabric: 72 m

Fabric for one gho: 4 m

Cost of fabric: Nu 150 for each metre

Cost of lining for one gho: Nu 200

- Students can then work in pairs to complete the activity.

While you observe students at work, you might ask questions such as the following:

- *Why did you multiply to find the cost of each gho?* (I knew the price for 1 m of fabric, so I had to multiply by the number of metres that are needed.)
- *Why did you divide 72 by 4?* (I had to find out how many groups of 4 are in 72 because the tailor uses 4 m for each gho and there are 72 m.)
- *Did you multiply or divide to answer part C?* Why? (I multiplied. I know how much 1 m of fabric costs, and I have 72 groups of that number, so I multiply.)
- *What operations did you perform to answer part D?* (I had to subtract the cost to make the gho from the cost of buying it. I had to add the cost of the fabric to the cost of the lining to find the cost of making the gho. I had to multiply to get the cost of the fabric.)

## Skills You Will Need

- To ensure students have the required skills for this unit, assign these questions.
- You may wish to check that students recall how to find the perimeter of a shape and the formula for the area of a rectangle before assigning **question 10**.
- Students can work individually.

## Answers

<p><b>A.</b> Nu 800 [<math>4 \times 150 + 200</math>]</p> <p><b>B.</b> 18 ghos [<math>72 \div 4</math>]</p> <p><b>C.</b> Nu 10,800 [<math>72 \times 150</math>]</p> <p><b>D. i)</b> Nu 200 [<math>1000 - 800</math>]      <b>ii)</b> Nu 3600 [<math>18 \times 200</math>]</p>	<p><b>E. Sample response:</b> It takes 4 m of fabric to make a gho. The fabric for some ghos costs Nu 150 a metre, but for other ghos it costs Nu 200 a metre. How much more would you pay for fabric to make 10 more expensive ghos than for fabric to make 10 less expensive ghos? (Nu 2000)</p>													
<p><b>1. Sample responses:</b>  <b>a)</b> about 1600 [<math>40 \times 40 = 1600</math>]  <b>b)</b> about 7200 [<math>80 \times 90 = 7200</math>]  <b>c)</b> about 500 [<math>3000 \div 6 = 500</math>]  <b>d)</b> about 60 [<math>480 \div 8 = 60</math>]</p> <p><b>2. a)</b> 1800      <b>b)</b> 4200      <b>c)</b> 600      <b>d)</b> 900</p> <p><b>3. Sample responses:</b> <math>47 \times 22 = 800 + 140 + 80 + 14</math>  <math>\begin{array}{r} 40 \\ + 7 \end{array}</math></p> <p><b>a)</b></p> <table border="1" style="display: inline-table; vertical-align: middle;"> <tr> <td style="padding: 5px;">20</td> <td style="padding: 5px;"><math>20 \times 40 = 800</math></td> <td style="padding: 5px;"><math>20 \times 7 = 140</math></td> </tr> <tr> <td style="padding: 5px;">+</td> <td></td> <td></td> </tr> <tr> <td style="padding: 5px;">2</td> <td style="padding: 5px;"><math>2 \times 40 = 80</math></td> <td style="padding: 5px;"><math>2 \times 7 = 14</math></td> </tr> </table>	20	$20 \times 40 = 800$	$20 \times 7 = 140$	+			2	$2 \times 40 = 80$	$2 \times 7 = 14$	<p><b>b)</b> <math>31 \times 31 = 900 + 30 + 30 + 1</math></p> <table border="1" style="display: inline-table; vertical-align: middle;"> <tr> <td style="padding: 5px;"><math>30 \times 30 = 900</math></td> <td style="padding: 5px;"><math>30 \times 1 = 30</math></td> </tr> <tr> <td style="padding: 5px;"><math>1 \times 30 = 30</math></td> <td style="padding: 5px;"><math>1 \times 1 = 1</math></td> </tr> </table> <p><b>4. a)</b> 1824      <b>b)</b> 1872  <b>c)</b> 3069      <b>d)</b> 1349</p>	$30 \times 30 = 900$	$30 \times 1 = 30$	$1 \times 30 = 30$	$1 \times 1 = 1$
20	$20 \times 40 = 800$	$20 \times 7 = 140$												
+														
2	$2 \times 40 = 80$	$2 \times 7 = 14$												
$30 \times 30 = 900$	$30 \times 1 = 30$													
$1 \times 30 = 30$	$1 \times 1 = 1$													

**Answers [Continued]**

**5. Sample responses:**

**a) 12,448**

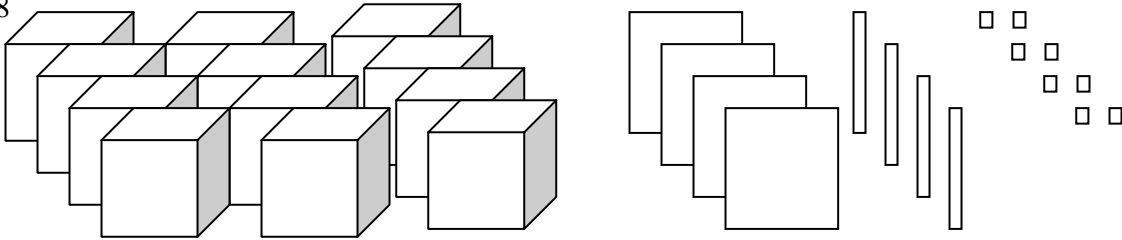

**b) 12,024**

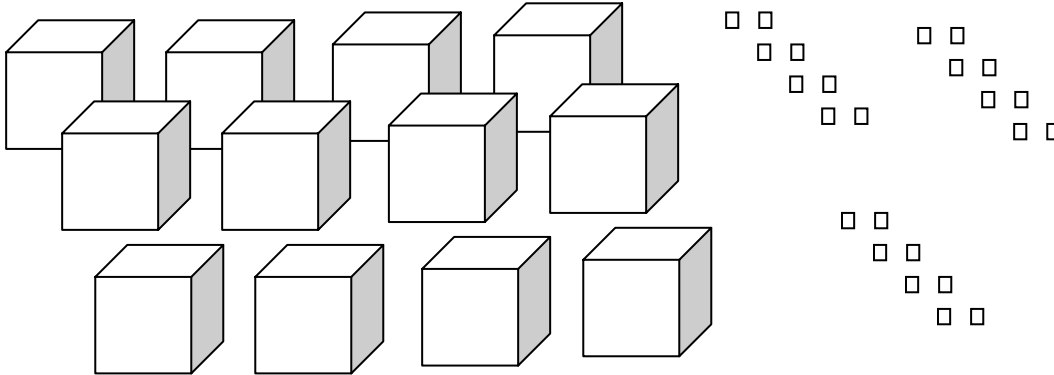

**c) 411 R 1**

Thousands	Hundreds	Tens	Ones
1	2	3	4
	12	3	4
$\div 3$			
	$12 \div 3$	$3 \div 3$	$4 \div 3$
	4	1	1 R 1

**d) 530**

Thousands	Hundreds	Tens	Ones
2	1	2	0
	20	12	0
$\div 4$			
	$20 \div 4$	$12 \div 4$	$0 \div 4$
	5	3	0

**6. a) 18,672**

**b) 15,684**

**9. a) 872 R 2**

**b) 995**

**c) 44,650**

**d) 10,962**

**c) 714**

**d) 465 R 4**

**7. A and C**

**e) 160**

**f) 182**

**g) 542**

**h) 63 R 44**

**8. a) 54**

**b) 36**

**c) 420**

**10. a) Addition**

**b) Multiplication**

**c) Division**

**Supporting Students**

*Struggling students*

- Some students may need help to see that you can use different estimates for a number. You may wish to use a number line to show why, for example, you could estimate 4.3 by using either 4 or 5.

*Enrichment*

- Students may create other questions like **question 7** for classmates to solve using values other than 10, for example, calculations that are about 20 or about 100.

# Chapter 1 Multiplication

## 3.1.1 Estimating a Product

Curriculum Outcomes	Outcome relevance
<b>6-B2 Estimation Strategies for Multiplication and Division: whole numbers and decimals</b> <ul style="list-style-type: none"><li>• apply estimation strategies: rounding, front-end</li></ul>	<ul style="list-style-type: none"><li>• It is important to estimate products for predicting calculated answers and for checking calculations.</li><li>• Sometimes the context of a problem is such that only an estimate is required; students should be able to determine when this is the case.</li></ul>

Pacing	Materials	Prerequisites
1 h	None	<ul style="list-style-type: none"><li>• estimating a decimal as a whole number</li><li>• multiplying by simple multiples of 10 or 100 using mental math</li><li>• understanding <math>1 \text{ cm}^2</math> and <math>1 \text{ m}^2</math></li></ul>

### Main Points to be Raised

- You can estimate the answer to a problem if you do not need an exact calculation.
- To estimate, it is a good idea to use numbers that are multiples of 10, 100, or 1000. You might round up or down, depending on the numbers used.
- When you multiply two numbers, if you overestimate one of the factors, you should sometimes underestimate the other number to balance it.
- You can estimate the product of two decimals by using nearby whole number values.

### Try This — Introducing the Lesson

**A.** Allow students to try this alone or with a partner. While you observe students at work, you might ask questions such as the following:

- *Did you estimate low or high? (I estimated low because 1 was the easiest estimate to use.)*
- *Was it okay to use the same estimate for both 1.15 and 1.1 even though they are different? (Yes, because it is only an estimate.)*
- *Is it reasonable that your answer to **part ii** was so much greater than your answer to **part i**? (Yes. Centimetres are a lot smaller than metres, so it should take a lot more square centimetres than square metres to cover an area.)*

### The Exposition — Presenting the Main Ideas

- Present the following problem:

*Is an 11-year-old closer to 1000 days old, 5000 days old, or 10,000 days old?*

Have students discuss the answer in pairs or in small groups.

Allow groups to share their answers and solutions with the class.

- Help the students notice that some of them used numbers like 350 or 400 to estimate the number of days in a year. Some used 10 as an estimate for 11 to solve the problem. Discuss why people use estimates (because it is relatively easy to multiply by such numbers using mental math, especially by 400 and 10).
- Discuss why you might round 11 down to 10 and 365 up to 400. Point out that since one number is rounded up and the other is rounded down, it is hard to tell if the resulting estimate is too high or too low. Discuss why it does not matter in this case ( $10 \times 400$  is not at all close to 1000 or 10,000).
- Have students turn to **page 71** in their texts to read through the exposition.
- Follow up by discussing why the low estimate of  $10 \times 300$  is probably not a good estimate. Discuss the two estimates of  $2.4 \times 0.9$  shown at the bottom of the box. Ask students which estimate they would use and why.

### Revisiting the Try This

**B.** This question allows students to think about the values they used to estimate the answer to **part A**.

## Using the Examples

- Present the question in the example to the students. Ask them to solve the problem by estimating. They can then compare their work to the solutions on **page 72** of the student text. Ask them which solution they used, **solution 1 or 2**, or whether they did something entirely different.

## Practising and Applying

### Teaching points and tips

**Q 1:** You may need to remind students that there are 52 weeks in a year, 365 days in a year, and 24 hours in a day.

**Q 2:** If students forget that the area of a rectangle is calculated by multiplying the length by the width, remind them. Remind students that they should always think about whether they are rounding up or down and why.

**Q 3:** Students might use decimals near 4, decimals near 5, or both.

**Q 4:** Students should realize that lower ones digits are more appropriate so that  $20 \times 30$  rather than  $30 \times 40$  would be a more reasonable estimate.

**Q 5:** There are many appropriate estimates for Nu 340.50, including Nu 300, Nu 340, and Nu 350.

**Q 6:** Students are likely to use whole number estimates for the decimals, 20 or 30 to estimate 28, and 3000 or 4000 to estimate 3500, but there are other reasonable estimates.

**Q 7:** Students might suggest a situation that is very close to one of the examples. This is acceptable.

### Common errors

- Some students simply use the first digit of a number to estimate the number, for example, they use 20 to estimate 28. Although this method is not wrong, students should consider how close their estimate is to the actual value and whether there might be a better estimate that is equally easy to use.

### Suggested assessment questions from Practising and Applying

<b>Question 2</b>	to see if students can estimate the product of two decimal values
<b>Question 5</b>	to see if students can solve a problem by estimating
<b>Question 6</b>	to see if students can recognize an incorrect estimate

## Answers

<b>A. Sample responses:</b> i) $1.1 \text{ m}^2$ ii) $11,000 \text{ cm}^2$	<b>B. Sample responses:</b> i) 1.2 and 1      ii) 120 and 100
<b>1. Sample responses:</b> a) about 400 weeks [ $8 \times 50 = 400$ ] b) about 3200 days [ $8 \times 400 = 3200$ ] c) about 75,000 h [ $25 \times 3000 = 75,000$ ] <b>2. Sample responses:</b> a) about $40 \text{ m}^2$ [ $8 \times 5 = 40$ ] b) about $72 \text{ m}^2$ [ $6 \times 12 = 72$ ] c) about $9 \text{ m}^2$ [ $3 \times 3 = 9$ ] <b>3. Sample response:</b> $3.9 \times 4.9$ ; $4.2 \times 5.1$ ; $3.8 \times 5.1$	<b>4. Sample responses:</b> a) 1 and 2 b) 8 and 9 <b>5.</b> About Nu 680 <b>6.</b> A and C <b>7. Sample response:</b> If you want to know whether you have enough money to buy a number of items, you might estimate the total price, using a high estimate to be sure.

## Supporting Students

### Struggling students

- Some students will need help to recognize how different estimates are possible. You may use number lines to help them see some alternatives.

For example, show that 4.3 is between 4 and 5, so either 4 or 5 could be an estimate.

### Enrichment

- Students can create questions like **question 4** for other students to solve.

## 3.1.2 Multiplying a Decimal by a Whole Number

Curriculum Outcomes	Outcome relevance
<p><b>6-B3 Multiply Decimals by Whole Numbers: pictorially, symbolically</b></p> <ul style="list-style-type: none"> <li>• compute products of whole numbers using an algorithm</li> <li>• know when to use a pencil/paper algorithm or a mental procedure</li> <li>• regularly estimate when performing computations</li> </ul> <p><b>6-B2 Estimation Strategies for Multiplication and Division: whole numbers and decimals</b></p> <ul style="list-style-type: none"> <li>• apply estimation strategies: rounding, front-end</li> </ul> <p><b>6-C1 Linear Equations: using open frames</b></p> <ul style="list-style-type: none"> <li>• solve simple linear open frame equations in context (e.g., 23 students, 8 are absent, others are sitting in groups of 3. How many groups? <math>3 \times \square + 8 = 23</math>)</li> <li>• replace open frames with letters</li> </ul>	<ul style="list-style-type: none"> <li>• Multiplying decimals by whole numbers is a real-world skill most citizens need. By focusing on estimation, students will be able to check their calculations.</li> <li>• The use of equations with open frames helps prepare students for algebraic thinking in higher math classes.</li> </ul>

Pacing	Materials	Prerequisites
1 h	<ul style="list-style-type: none"> <li>• Place Value Charts I (BLM)</li> </ul>	<ul style="list-style-type: none"> <li>• multiplying a 4-digit number by a 1-digit number</li> <li>• understanding that multiplication by 10 moves the digits of a number one space to the left, multiplication by 100 moves them two spaces to the left, and so on</li> <li>• familiarity with the associative principle of multiplication (to multiply three numbers, you can first multiply two of the values and then multiply by the third value)</li> <li>• familiarity with perimeter</li> </ul>

### Main Points to be Raised

- To multiply a multi-digit number by a 1-digit number, you can multiply the values represented by each digit on a place value chart and then regroup (or trade) as necessary.
- To multiply a 1-digit number by a multi-digit number, even if it involves a decimal, you can multiply each digit and then add the results. You regroup when you have more than 9 of one digit.
- Estimation is a useful tool to decide whether a calculation is correct.
- To multiply a decimal by 10, move each digit one space to the left. Similarly, to multiply by 100, move each digit two spaces to the left. To multiply by 1000, move each digit three spaces to the left.

### Try This — Introducing the Lesson

**A.** Allow students to try this alone or with a partner. While you observe students at work, you might ask questions such as the following:

- *Would it take Lobzang more or less than 12.4 s to run 300 m?* (More, because he is going three times as far.)
- *Would it take him more or less than 30 s?* (More, because if it took him 10 s to run 100 m, it would take 30 s to run 300 m, but he needs more than 10 s to run each 100 m.)
- *Why did you add 12.4 three times?* (Because  $300 \text{ m} = 100 \text{ m} + 100 \text{ m} + 100 \text{ m}$ , so I also had to add the number of seconds for 100 m that many times.)

### The Exposition — Presenting the Main Ideas

- Write the question  $3 \times 4125$  on the board. Ask students how to perform the calculation.
- Then write  $3 \times 4.125$ . Ask why you can read 4.125 as 4125 thousandths. Then ask why  $3 \times 4125$  thousandths is  $(3 \times 4125)$  thousandths.
- Invite students to look at **page 73** in the student text. Discuss how the place value chart correctly models the product. Remind students that this is how they learned to multiply whole numbers. The only difference is the place value columns that are used in this situation.

- Point out the calculation shown on **page 73**. Ask students to tell you the meaning of the 1 above the 2 hundredths in 4.125.
- Encourage students to think about why the result had to be 12.375 rather than 12,375 or 1.2375 or 123.75. Point out that because the product is a number close to 4 multiplied by 3, the answer needs to be close to 12.
- Ask students what  $10 \times 4.125$  would be. See if they suggest that it would have to be 41.25. If they do, ask why. If they do not, suggest that students look at the exposition on **page 74**. Work through the multiplication of  $10 \times 5.123$  with them.
- Ask why  $100 \times 5.123$  is 512.3 and  $1000 \times 5.123$  is 5123. Refer to the use of estimation to help make this make sense.

### Revisiting the Try This

**B.** Some students may have already used an exact value for **part A**. If so, encourage them to write the calculation as a product and to show the process for multiplying using a place value chart.

### Using the Examples

- Before students consider the examples, pose this question:  $40 \times 87 = 4 \times \blacksquare$ . Make sure students understand why  $\blacksquare$  must be greater than 87 and why it must be ten times as great.
- Work through **example 1** with the students. Talk about why mental math is used to multiply by 10.
- Present the questions from **example 2** for students to try. Ask them to try the questions and then to compare their work with the solutions in the text.

### Practising and Applying

#### Teaching points and tips

**Q 1:** Suggest that students think about whether they are rounding down or up to estimate.

**Q 2:** Provide Place Value Charts I (BLM) if possible. If not, students can draw a chart like those on **page 73 or 74**.

**Q 3:** Refer students to **example 1** if they struggle with this question.

**Q 4:** Observe whether students complete the full multiplication or just think about which digit moves to the tenths place.

For example, for **part b**, because the digits move two places to the left, it must be the 4 thousandths that will become 4 tenths.

**Q 7:** Students will need to think about how many 200s are in 1000 or in 20,000 to solve the problems.

**Q 9:** Students might use the **Try This** or **question 6** and **question 7** as models for their problems.

#### Common errors

- Sometimes students move the digits in the opposite direction when they are multiplying by 10, 100, or 1000. Suggest that they think about what the product should be.

For example, for  $5.67 \times 1000$ , they should think that since it is about  $5 \times 1000$ , it would be 5000.

#### Suggested assessment questions from Practising and Applying

<b>Question 1</b>	to see if students can multiply a whole number by a decimal
<b>Question 5</b>	to see if students can multiply a decimal by a multiple of 10 or 100
<b>Question 6</b>	to see if students can solve a real-world problem involving multiplication of a decimal by a whole number
<b>Question 9</b>	to see if students can describe a situation that requires the multiplication of a decimal by a whole number

## Answers

<b>A. Sample response:</b> About 36 s; $3 \times 12 = 36$		<b>B. i)</b> 37.2 s <b>ii)</b> My estimate of 36 is a bit low because I rounded 12.4 down to 12 before I multiplied.																																																													
<b>1. a) i)</b> 37.134 <b>ii)</b> 119.45 <b>iii)</b> 751.8 <b>iv)</b> 419.36 <b>[b) Sample response:</b> I checked parts i) and iv). i) $9 \times 4.126$ is about $9 \times 4 = 36$ , so 37.134 makes sense. iv) $8 \times 52.42$ is about $8 \times 50 = 400$ , so 419 makes sense.]																																																															
<b>2. Sample responses:</b> <b>a)</b> <table border="1" style="width: 100%; text-align: center;"> <thead> <tr> <th>Hundreds</th> <th>Tens</th> <th>Ones</th> <th>Tenths</th> <th>Hundredths</th> <th>Thousandths</th> </tr> </thead> <tbody> <tr> <td></td> <td><math>4 \times 3</math></td> <td><math>4 \times 8</math></td> <td><math>4 \times 1</math></td> <td><math>4 \times 2</math></td> <td><math>4 \times 5</math></td> </tr> <tr> <td></td> <td>12</td> <td>32</td> <td>4</td> <td>8</td> <td>20</td> </tr> <tr> <td></td> <td>15</td> <td>2</td> <td>4</td> <td>10</td> <td></td> </tr> <tr> <td>1</td> <td>5</td> <td>2</td> <td>5</td> <td></td> <td></td> </tr> </tbody> </table> <b>b)</b> <table border="1" style="width: 100%; text-align: center;"> <thead> <tr> <th>Hundreds</th> <th>Tens</th> <th>Ones</th> <th>Tenths</th> <th>Hundredths</th> <th>Thousandths</th> </tr> </thead> <tbody> <tr> <td></td> <td><math>9 \times 5</math></td> <td><math>9 \times 3</math></td> <td><math>9 \times 1</math></td> <td><math>9 \times 9</math></td> <td><math>9 \times 1</math></td> </tr> <tr> <td></td> <td>45</td> <td>27</td> <td>9</td> <td>81</td> <td>9</td> </tr> <tr> <td></td> <td>47</td> <td>7</td> <td>17</td> <td>1</td> <td>9</td> </tr> <tr> <td>4</td> <td>7</td> <td>8</td> <td>7</td> <td>1</td> <td>9</td> </tr> </tbody> </table>				Hundreds	Tens	Ones	Tenths	Hundredths	Thousandths		$4 \times 3$	$4 \times 8$	$4 \times 1$	$4 \times 2$	$4 \times 5$		12	32	4	8	20		15	2	4	10		1	5	2	5			Hundreds	Tens	Ones	Tenths	Hundredths	Thousandths		$9 \times 5$	$9 \times 3$	$9 \times 1$	$9 \times 9$	$9 \times 1$		45	27	9	81	9		47	7	17	1	9	4	7	8	7	1	9
Hundreds	Tens	Ones	Tenths	Hundredths	Thousandths																																																										
	$4 \times 3$	$4 \times 8$	$4 \times 1$	$4 \times 2$	$4 \times 5$																																																										
	12	32	4	8	20																																																										
	15	2	4	10																																																											
1	5	2	5																																																												
Hundreds	Tens	Ones	Tenths	Hundredths	Thousandths																																																										
	$9 \times 5$	$9 \times 3$	$9 \times 1$	$9 \times 9$	$9 \times 1$																																																										
	45	27	9	81	9																																																										
	47	7	17	1	9																																																										
4	7	8	7	1	9																																																										
<b>3. a)</b> 60.8 <b>b)</b> 495.5		<b>8. a)</b> 32.92 m <b>b)</b> 329.2 m <b>c)</b> The second value is 10 times as great as the first value.																																																													
<b>4. a)</b> 1 <b>b)</b> 4 <b>c)</b> 0		<b>9. Sample response:</b> I cut a 2.3 m rope into 5 equal pieces. How long was each piece? (0.46 m)																																																													
<b>5. a)</b> 51.23 <b>b)</b> 304.1 <b>c)</b> 561.6 <b>d)</b> 1798		<b>[10. Sample response:</b> When you multiply by a decimal, the process is the same as when you multiply by a whole number, but different place values are involved.]																																																													
<b>6.</b> 56 kg																																																															
<b>7. a)</b> 128.5 s <b>b)</b> 2570 s																																																															

## Supporting Students

### Struggling students

- Some students might have difficulty using both a place value chart and symbolic calculations. If so, allow students to use whichever method they find more comfortable.
- Some students will find it difficult to complete **question 4** without completing the full multiplication. If that is the case, allow them to do so, but point out afterwards why the full multiplication would not have been necessary.

### Enrichment

- Students might create problems involving decimal multiplication to fit certain conditions. For example, they might create a problem where multiplication is involved and the product is of the form ■■.56.

### 3.1.3 Multiplying Decimals

Curriculum Outcomes	Outcome relevance
<p><b>6-B4 Multiply Decimals by Decimals: concretely and symbolically</b></p> <ul style="list-style-type: none"> <li>• use meaningful strategies to calculate products of decimals</li> <li>• regularly estimate when performing computations</li> </ul> <p><b>6-B2 Estimation Strategies for Multiplication and Division: whole numbers and decimals</b></p> <ul style="list-style-type: none"> <li>• apply estimation strategies: rounding, front-end</li> </ul>	<ul style="list-style-type: none"> <li>• Many real-world calculations, including the calculation of areas, involve the multiplication of two decimals.</li> <li>• The continued use of estimation will ensure that students can appropriately check their calculations.</li> </ul>

Pacing	Materials	Prerequisites
1.5 h	<ul style="list-style-type: none"> <li>• Hundredths Grids (BLM)</li> <li>• Place Value Charts I (BLM)</li> </ul>	<ul style="list-style-type: none"> <li>• multiplying whole numbers</li> <li>• representing a product as the area of a rectangle whose dimensions are the factors</li> <li>• representing a 1-digit, 2-digit, or 3-digit decimal as a multiple of 0.1, 0.01, or 0.001</li> </ul>

#### Main Points to be Raised

- To multiply by a decimal means that you take a portion of the number being multiplied.
- You can show the product of two decimals as the area of a rectangle where each decimal is one of the dimensions. If the decimals are tenths, you can use a hundredths grid model to show the multiplication.

#### Try This — Introducing the Lesson

- A.** Allow students to try this alone or with a partner. While you observe students at work, you might ask questions such as the following:
- *How do you know that the width of Eden's picture is more than half of 4.4 cm?* (0.5 is half, and 0.6 is more than 0.5.)
  - *How do you know that the length of Eden's picture is about 3.5 cm?* (6.7 cm is close to 7 cm and 0.6 is close to 0.5, so I took half of 7 cm, which is 3.5 cm.)
  - *How else might you estimate the width of the picture?* (I could estimate 4.4 as 4 cm. Since I went down to 4, I might raise 0.6 up to 0.7. Then I would use 2.8 cm as my estimate.)

#### The Exposition — Presenting the Main Ideas

- Ask students what each of these means:  $4 \times 6$ ,  $3 \times 6$ , and  $1 \times 6$ . Point out that in each case you are counting the total number of items in that many groups of 6.
- Ask what they think  $0.5 \times 6$  might mean. If they do not suggest it, help them see that it makes sense that the answer, 3, is half of a group of 6 because 0.5 is one half.
- Present the question  $0.5 \times 0.6$ . Some students will realize right away that this is 3 tenths, which is half of 6 tenths. Next, draw a 10-by-10 grid on the board. Mark a distance of 0.5 across and a distance of 0.6 down, and shade in a rectangle. Show students that the area of the rectangle is 30 (6 rows of 5) hundredths (because each square is one hundredth of a whole), which is 0.3.
- Have students look at **page 77** in their texts to see a similar diagram for  $0.3 \times 0.6$ .
- Help students understand that the shaded rectangle is 0.3 of 0.6 because 0.6 is the number of squares in 6 columns of the grid, and 0.3 of 6 columns are shaded.
- Show students how you could have written 6 tenths  $\times$  3 tenths =  $(6 \times 3) \times$  (tenths  $\times$  tenths), or 18 hundredths. Or, you could have written 6 tenths  $\times$  0.3 = 1.8 tenths, which is also 0.18.



## Revisiting the Try This

**B.** Students need to multiply  $0.6 \times 4.4$  and  $0.6 \times 6.7$ . They may choose to multiply separately the whole number parts and the decimal parts, and then put them together.

For example, for  $0.6 \times 4.4$ , they could do  $0.6 \times 4 + 0.6 \times 0.4 = 0.24 + 2.4 = 4.64$ .

## Using the Examples

- Work through **example 1** with the students. Make sure they understand why they are multiplying by 0.5 for **part a)** and by 0.6 for **part b)**. Make sure they understand how the place value chart is used to multiply by 0.1 (or by 0.01) because digits can easily be moved.

- The solution for **example 1 part a)** shows multiplying first by 5 and then by 0.1. Demonstrate how the student could instead have multiplied first by 0.1 and then by 5.

Tens	Ones	Tenths	Hundredths
1	5	5	
	1	5	5
	$5 \times 1$	$5 \times 5$	$5 \times 5$
	5	25	25
	7	7	5

- Many students will appreciate the solution to **example 1 part b)**, which helps them clearly understand why the numbers are multiplied as if there were no decimals and then adjusted to account for the number of decimal places. You will notice that the focus is on understanding how the decimal point is placed, not just on applying a learned rule.

- Present the questions from **examples 2 and 3**. Let students try the questions alone or in pairs and then compare their answers to the answers shown. If they are not sure how to proceed, have them read through the examples. Make sure they realize that the various strategies they used all allowed them to see that you can multiply the amounts as if there were no decimal points and then adjust the product appropriately.

## Practising and Applying

### Teaching points and tips

**Q 1:** Provide grid paper for students to use. If that is not possible, they can draw sketches of 10-by-10 grids and colour them.

**Q 2:** Students can use a variety of strategies. They can use grids, they can multiply using words, e.g.,  $0.5 \times 0.8$  as 5 tenths  $\times$  8 tenths, or they might use place value charts.

**Q 3:** Encourage students to complete **parts a) and b)** using mental math or a place value chart.

**Q 5:** Make sure students realize they do not have to actually do the multiplication. The digits are already there.

**Q 6:** Encourage students to keep in mind that 0.5 means one half. They might either divide 12 in half and 0.4 in half and then add the partial quotients or they might think about what number multiplied by 2 is 12.4.

**Q 8:** Students might separately multiply by 3 and by 0.5 and then add the parts.

**Q 9:** Students only need to estimate the product.

### Common errors

- If students are given a rule to use without a firm foundation, they may count incorrectly the number of decimal places in the product. Once they have learned to estimate, they will not be as likely to make this error.

For example, they might calculate  $3.1 \times 9.45 = 292.95$ , counting decimal places from the left instead of the right.

### Suggested assessment questions from Practising and Applying

<b>Question 1</b>	to see if students can represent the product of two decimals using a pictorial model
<b>Question 3</b>	to see if students can calculate the product of decimals
<b>Question 5</b>	to see if students can use estimation to determine a decimal product
<b>Question 8</b>	to see if students can solve a real-world problem involving the multiplication of decimals

## Answers

**A. Sample response:**

About 2.5 cm by 3.5 cm; I took half of each measurement and then added on a bit because 0.6 is a bit more than half

**B.**  $0.6 \times 4.4 = 2.64$  cm and  $0.6 \times 6.7 = 4.02$  cm.

**1. a)** 0.32

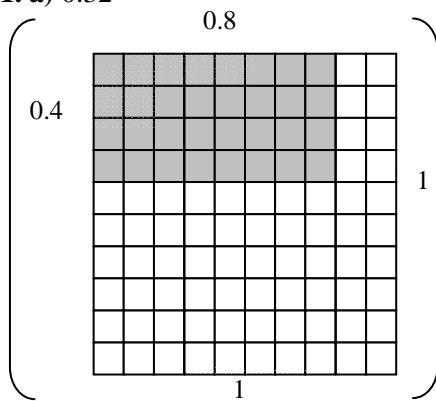

**b)** 0.18

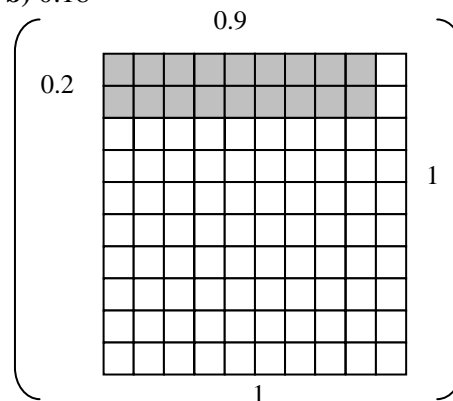

**c)** 0.49

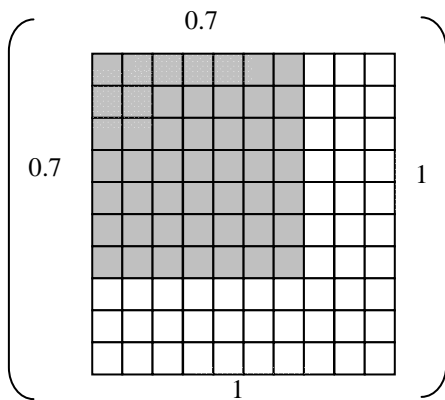

**d)** 0.14

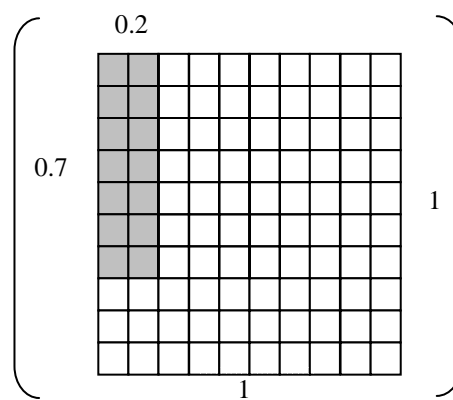

**2. [a] Sample responses:**

**i) First way:** Use a grid; shade a rectangle 0.5 by 0.8.

**Second way:** Multiply  $5 \times 0.8$ , then take one tenth.

**ii) First way:** Use a grid; shade a rectangle 0.6 by 0.9.

**Second way:** Multiply  $6 \times 0.9$ , then take one tenth.

**ii) First way:** Multiply 2 by 14, then write the answer as hundredths.

**Second way:** Multiply  $2 \times 1.4$ , then take one tenth.

**iii) First way:**  $1.0 = 1$ , so when you multiply by 1, you just write the other number.

**Second way:** Multiply  $6 \times 10$ , then write the answer as hundredths.]

**b) i)** 0.4      **ii)** 0.54      **iii)** 0.28      **iv)** 0.6

**3. a)** 0.09      **b)** 1.35      **c)** 11.89

**d)** 11.977      **e)** 17.578

**[4. Sample response:**

All you have to do is move the digits one place to the right. You do not really have to do any calculations.]

**5. a)** 27.30

**b)** 39.44

**c)** 112.86

**d)** 313.088

**[6. Sample response:**

Since 0.5 is one half, you can mentally divide 12 by 2 and 0.4 by 2, and then put the parts together.

For  $0.8 \times 12.4$ , you have to multiply all 3 parts by 8 and regroup. You also have to think about where to place the decimal point.]

**7. Sample response:**  $\underline{87} \times \underline{0.6}$

**8.** 113.75 km

**9. Sample response:** about 1000 km

<p><b>10.</b> <math>16.32 \text{ m}^2</math></p> <p><b>11.</b> <math>1.666 \text{ m}</math></p>	<p>[<b>12.</b> <i>Sample responses:</i></p> <p><b>a)</b> When I multiply, I am covering only part of the hundredths grid. Since the whole grid is worth 1, part of it is worth less than 1.</p> <p><b>b)</b> The first factor is between 5 and 6 and the second factor is between 4 and 5. The product has to be between the product of the two lower values and the product of the two upper values. So the product is between <math>5 \times 4 = 20</math> and <math>6 \times 5 = 30</math>.]</p>
---	---

## Supporting Students

### *Struggling students*

- Some students will have difficulty multiplying a 3-digit or 4-digit decimal value by a 2-digit decimal value. You may choose to not assign questions like **questions 3 d) and e)** or **question 8** until these students have a better understanding of the process.

### *Enrichment*

- Students can create and solve other questions like **question 7**.

For example they may wish to use the digits 4, 5, and 8 in an arrangement like the one in the question to get a product close to 22.

## GAME: Target 10

- This game is designed to allow students to practise multiplying two decimal values.
- Students who are able to multiply two 2-digit whole numbers will be more successful with this game.
- Note that determining which product is closer to 10 will often require only estimation, as shown by the example on page 81 in the student textbook.

## Chapter 2 Division

### 3.2.1 Estimating a Quotient

Curriculum Outcomes		Outcome relevance
<b>6-B2 Estimation Strategies for Multiplication and Division: whole numbers and decimals</b> <ul style="list-style-type: none"><li>• apply estimation strategies: rounding, front-end</li></ul>		<ul style="list-style-type: none"><li>• Estimating quotients is important both for predicting what calculated answers might be and for checking calculations.</li><li>• Sometimes the context of a problem is such that only estimate is required; students should be able to determine when this is the case.</li></ul>
Pacing	Materials	Prerequisites
1 h	None	<ul style="list-style-type: none"><li>• dividing whole numbers</li><li>• formula for area of a rectangle</li></ul>

#### Main Points to be Raised

- You can estimate the answer to a problem if you do not need an exact calculation.
- To estimate, it is a good idea to use numbers that are multiples of 10, 100, or 1000 or numbers that allow you to use multiplication facts. You might round up or down, depending on the numbers involved.
- You can estimate the quotient of two decimals by using nearby whole number values.

#### Try This — Introducing the Lesson

**A.** Allow students to try this alone or with a partner. While you observe students at work, you might ask questions such as the following:

- *Why did you multiply the 750 by 2?* (The sellers wanted to provide 2 bottles for each of the 750 people, so they needed to bring 1500 bottles.)
- *How did you estimate?* (I used 25 instead of 24 because I know that there are four 25s in 100. Then I estimated there are  $4 \times 15 = 60$  groups of 25 in 1500.)
- *How else might you have estimated?* (I could have estimated 750 as 800.)

#### The Exposition — Presenting the Main Ideas

- Read to students the problem in italics on **page 82** of the student text. Ask them why an estimate, rather than a calculation, would answer the question.
- Present the expression  $416 \div 8$ . Ask students how they would estimate the quotient. Discuss why the calculation would be easier to perform if you rounded to 400 rather than to 420. Ask how students would estimate several other quotients, e.g.  $520 \div 7$  (perhaps as  $560 \div 7$  or as  $490 \div 7$ ),  $2013 \div 6$  (perhaps as  $1800 \div 6$ ), and  $817 \div 7$  (perhaps as  $777 \div 7$  or as  $800 \div 8$ ). Each time, it is helpful to think of related multiplication facts.
- Write the question  $38.4 \div 6$  on the board. Ask why someone might estimate this as  $36 \div 6$ .  
Next, write  $28.4 \div 6.4$  and ask why  $28 \div 7$  might be a reasonable estimate.
- Suggest that students read through the exposition on **page 82**.

#### Revisiting the Try This

**B.** Students can record the division estimation they used in **part A**, but you might ask them what other estimated values would have been reasonable.

#### Using the Examples

- Present the question from the example to students. You may ask them to try to solve the problem and then compare their solution to the solution in the student text.

## Practising and Applying

### Teaching points and tips

**Q 1:** There are many possible answers for these.

For example, students might estimate **part c)** by using  $150 \div 5$ ,  $150 \div 6$ , or even  $135 \div 6$ . For **part b)**, students might use  $45 \div 1.5$  if they know that  $3 \times 15 = 45$ . They could think, “1.5 is half of 3, so  $45 \div 3 = 15$ . I can multiply by 2 because I divided by a number that is half as big.” They could also estimate **part b)** as halfway between  $50 \div 1$  and  $50 \div 2$ , to get about 35.

**Q 2:** Students need to find the missing value in the formula  $A = l \times w$ . A variety of estimates are reasonable for each part.

**Q 3:** The purpose of this question and of **question 6** is to have students consider whether their calculations underestimate or overestimate the results.

**Q 4:** Make sure students need to understand that each grey square represents an entire number, not just one digit.

**Q 5:** In this question, each blank square represents a single digit, not an entire number.

**Q 7:** This question is designed to help students see that one of the most important uses of estimation is for checking calculations.

**Q 8:** Students should have opportunities to discuss when it is useful to estimate. This question might best be handled in small groups or in a class discussion.

### Common errors

- Many students will estimate by simply rounding the quotient and/or the divisor to the nearest multiple of 10 or 100. If they round only the quotient, it may lead to calculations that are difficult to perform mentally. If they round the divisor, their result might be far from the actual quotient. Students will only learn this through experience, but you can make them aware of it nonetheless.

For example, you might have them consider  $432 \div 6$ . If a student writes  $430 \div 6$ , he or she will see that it is difficult to calculate mentally. The same is true for  $400 \div 6$ . If he or she uses  $430 \div 10$  or  $400 \div 10$ , the estimate is far from the actual quotient.

### Suggested assessment questions from Practising and Applying

<b>Question 1</b>	to see if students can estimate a quotient
<b>Question 6</b>	to see if students can estimate appropriately
<b>Question 7</b>	to see if students can use an estimate to check the calculation of a quotient

### Answers

<b>A. Sample response:</b> 60 cases	<b>B. i)</b> $1500 \div 24$ <b>ii) Sample response:</b> $1500 \div 25$ ; I used these because it is easy to divide 150 by 25 (6) and then I can multiply the result by 10 in my head.
<b>1. Sample responses:</b> <b>a)</b> about 25 kilometres in 1 h [ $25 \div 1 = 25$ ] <b>b)</b> about 30 kilometres in 1 h [ $45 \div 1.5 = 45 \div 3 \times 2 = 30$ ] <b>c)</b> about 25 kilometres in 1 h [ $150 \div 6 = 25$ ] <b>2. Sample responses:</b> <b>a)</b> About 3 m <b>b)</b> About 5 m <b>c)</b> About 8 m <b>3. C;</b> [ <i>Sample response:</i> I can do $12 \div 8$ in my head. It is one and a half.] <b>4. Sample response:</b> $19.6 \div 4.9$ or $20.5 \div 5.1$ or $19.8 \div 5.1$	<b>5. Sample responses:</b> <b>a)</b> $100 \div 26$ <b>b)</b> $100 \div 29$ [because it's closer to 3 than to 4] <b>[6. Sample response:</b> Decrease both; I would decrease 11 to 10 and decrease 3012 to 3000 to make the division easier.] <b>7. B and D</b> <b>[8. Sample response:</b> I use a multiplication fact to figure out the multiples of a divisor. That way I can switch the dividend to something I can divide easily by the divisor.]

## Supporting Students

### *Struggling students*

- Students who have difficulty with whole number division will likely have difficulty with decimal division. You may wish to support these students by allowing them to use a multiplication chart or table to recall good choices for estimating.

For example, for a question like  $521 \div 7.8$ , they could look at a multiplication chart for numbers near 52 that appear in the 7 or 8 rows.

### *Enrichment*

- Students might consider the many possible quotient estimates if they rearrange the digits of  $314.2 \div 5.6$  (to, for example,  $134.2 \div 6.5$  or  $415.6 \div 2.3$ , and so on).

## 3.2.2 Dividing a Decimal by a Whole Number

Curriculum Outcomes	Outcome relevance
<p><b>6-B5 Whole Numbers and Decimals: single-digit division</b></p> <ul style="list-style-type: none"> <li>• relate to whole number division</li> <li>• link concrete models to algorithms</li> <li>• regularly estimate when performing computations</li> </ul> <p><b>6-B2 Estimation Strategies for Multiplication and Division: whole numbers and decimals</b></p> <ul style="list-style-type: none"> <li>• apply estimation strategies: rounding, front-end</li> </ul>	<p>Dividing decimals by whole numbers is a real-world skill most citizens need. By focusing on estimation, students will be able to check their calculations.</p>

Pacing	Materials	Prerequisites
1 h	None	<ul style="list-style-type: none"> <li>• dividing whole numbers</li> <li>• renaming a decimal in other forms</li> <li>• familiarity with the concept of perimeter and the formula for the area of a rectangle</li> </ul>

### Main Points to be Raised

- One way to divide a decimal by a whole number is to ignore the decimal, look at the quotient, and then use an estimate to place the decimal point in the quotient.
- Another way to divide a decimal by a whole number is to rename it as a whole number of tenths, hundredths, or thousandths, divide the whole number by the divisor, and then adjust the answer to reflect the appropriate unit.
- A third way to divide a decimal is to perform standard long division and continue the process to the right of the decimal point. Sometimes we rename the dividend using additional zeros in places to the right so that we can use more digits in the quotient.
- To divide by 10 (or by 100) using mental math, you can move digits one (or two) place(s) to the right because tens (or hundreds) become ones.

### Try This — Introducing the Lesson

**A.** You may need to explain hurdles to students if they are not familiar with them, although the illustration should help them with this. Hurdles are a track and field event where runners leap over barriers on the track. Encourage students to draw a diagram to help them with the question. Allow students to try this alone or with a partner.

While you observe students at work, you might ask questions such as the following:

- *What does your diagram show?* (First I have a section showing 13 m, then I show the 10 hurdles as 10 lines, so there are 9 spaces between them, and then there is another section showing 10.5 m.)
- *Why did you divide by 9 instead of by 10?* (There are 10 hurdles but there are only 9 spaces between them.)
- *Why did you divide 76.5 by 9 instead of dividing 100 by 9?* (I did not need to count the 13 m and 10.5 m sections because I already knew how long those were.)

### The Exposition — Presenting the Main Ideas

• Work through the exposition on **pages 84 and 85** of the student text with the students. Guide them through the explanations. Make sure they see why 36.6 was rewritten as 36.60 to complete the division on **page 85**. They need to understand that this was only necessary because an exact answer (with no remainder) was desired. Sometimes, an exact answer is not possible, for example, when dividing 1.0 by 3, where there will always be a remainder.

### Revisiting the Try This

**B.** This question allows students to describe their calculations in **part A** more formally.

## Using the Examples

- Have students read through both solutions of the example in pairs. When they have finished, make sure they understand why they were able to divide by 10 either first or last when they divided by 20 or by 80.
- Show them how, if they had been dividing 428 by 6, they would have had a remainder even after using an extra zero in the hundredths place.

## Practising and Applying

### Teaching points and tips

**Q 1:** Students can use whichever method they prefer

**Q 2:** Discourage students from using paper and pencil for these questions. If they need the support of a place value chart, that is acceptable.

**Q 3:** Remind students to look at the example for support for this question.

**Q 4:** Students need to do two steps to solve this problem — they first divide by 2 and then divide the quotient by 5.

**Q 5:** Students should report their answers to one decimal place.

**Q 7:** You may need to suggest to students the idea of using two extra zeros to get an exact answer, since they had not seen this before. (Technically, when solving measurement problems, the reported answer should have the same number of decimal places as the original value, but that is ignored in this situation.)

**Q 8:** Students might model their problem on the **Try This** or one of **questions 4, 5, 6, and 7**.

### Common errors

- Some students will report a quotient and remainder rather than using extra zeros in the dividend to get a decimal answer. Refer them back to the last part of the exposition and to **part b)** of **example 2**.

### Suggested assessment questions from Practising and Applying

<b>Question 1</b>	to see if students can divide a decimal by a single-digit divisor
<b>Question 3</b>	to see if students can divide a decimal by a 2-digit multiple of ten
<b>Question 6</b>	to see if students can solve a two-step problem involving decimal division

## Answers

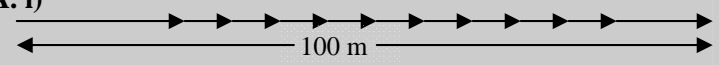
<b>A. i)</b> 	<b>ii)</b> 8.5 m  <b>B.</b> $76.5 \div 9 [(100 - 13 - 10.5) \div 9]$
<b>1. a) i)</b> 5.01 <b>ii)</b> 5.07 <b>iii)</b> 23.5 <b>iv)</b> 8.21 <b>[b) Sample response:</b> I checked parts i) and iii). For i), $5 \times 5.01 = 25.05$ . For iii), $4 \times 23.5 = 94$ .	<b>5.</b> 1.5 m  <b>6.</b> $2.3 \text{ km}^2$
<b>2. a)</b> 0.412 <b>b)</b> 3.892 <b>c)</b> 5.67 <b>d)</b> 0.567	<b>7.</b> 205.25 g
<b>3. a) i)</b> 3.56 <b>ii)</b> 5.03 <b>iii)</b> 5.46 <b>iv)</b> 5.41 <b>[b) Sample response:</b> I checked parts i) and iii). For 1), $71.2 \div 20$ is between $60 \div 20 = 3$ and $80 \div 20 = 4$ , so 3.56 seems right. For iii), $452.7 \div 90$ is about $450 \div 90 = 5$ , so 5.46 seems OK.	<b>8. Sample response:</b> 4.2 kg of flour is equally divided into 4 containers. How much flour is in each container? (1.05 kg)
<b>4. a)</b> 2.5 kg <b>b)</b> 0.5 kg	<b>9. Sample response:</b> $4.2 \div 4 = 1.05$

## Supporting Students

### Struggling students

- Struggling students may have difficulty with the two part questions such as **questions 3, 4, and 6**. You may suggest that struggling students work with a partner on these.

### Enrichment

- Encourage students to create and solve additional division problems like they were asked to do in **question 8**.



### 3.2.3 EXPLORE: Dividing by 0.1, 0.01, and 0.001

Curriculum Outcomes	Outcome relevance
<b>6-B6 Divide Mentally: whole numbers by 0.1, 0.01, 0.001</b> <ul style="list-style-type: none"><li>• recognize the pattern of changes produced by dividing by 0.1, 0.01, 0.001 is the same as that produced by multiplying by 10, 100, 1000</li><li>• describe these patterns in terms of place value changes</li></ul>	This essential exploration will support students' later work in dividing by decimals. Without this understanding, the rules for dividing by decimals may not make sense to them.

Pacing	Materials	Prerequisites
40 min	None	• dividing whole numbers by 1, 10, 100, or 1000

#### Exploration

• Invite students to work through the exploration in pairs. You may wish first to remind them of the terms *dividend*, *divisor*, and *quotient*. This will simplify discussion of the work afterwards.

For example, in  $4000 \div 1000 = 4$ , 4000 is the dividend, 1000 is the divisor, and 4 is the quotient.

While you observe students at work, you might ask questions such as the following:

- *What was happened to the divisor each time?* (It was divided by 10.)
- *What was happened to the quotient each time?* (It was 10 times as much.)
- *How did you calculate when the dividend was 5000?* (I used the same pattern again, but I wrote a 5 wherever there had been a 4.)
- *Why does it make sense that  $4000 \div 100$  is greater than  $4000 \div 1000$ ?* (There are more hundreds in 4000 than there are thousands in 4000.)

#### Observe and Assess

As students work, notice the following:

- Do students correctly calculate the quotients involving whole numbers?
- Do they easily observe the pattern in the divisors and the quotients?
- Can they summarize their observations clearly?
- Can they support their observations of the pattern to provide another reason why dividing by 0.01 is the same as multiplying by 100?
- Can they use their observations to provide a rule for dividing by decimal powers of ten?

#### Share and Reflect

After students have had sufficient time to work through the exploration, discuss questions such as these.

- *Why is the quotient greater when you divide by a lower number?*
- *Why is the quotient when you divide by 0.001 one thousand times as much as the number? How could you explain it without using the pattern?* [You may wish to show that there are 1000 thousandths in 1, so there would be  $2 \times 1000$  thousandths in 2,  $3 \times 1000$  thousands in 3, and so on.]
- *What rule did you describe for part D?*

## Answers

**A. i)** The dividend stays the same but divisor is divided by 10 each time.

**ii)**

$$4000 \div 1000 = 4$$

$$4000 \div 100 = 40$$

$$4000 \div 10 = 400$$

$$4000 \div 1 = 4000$$

$$4000 \div 0.1 = 40,000$$

$$4000 \div 0.01 = 400,000$$

$$4000 \div 0.001 = 4,000,000$$

**iii)** The dividend is multiplied by 10;

The dividend is multiplied by 100;

The dividend is multiplied by 1000.

**B. i)** 50,000    **ii)** 500,000    **iii)** 5,000,000

**C. Sample response:**

There are ten 0.1s in 1, twenty 0.1s in 2, thirty 0.1s in 3, forty 0.1s in 4, and so on. So there are ten 0.1s for each 1. That is like multiplying by 10.

**D.** To divide by 0.1, multiply by 10.

To divide by 0.01, multiply by 100.

To divide by 0.001, multiply by 1000.

## Supporting Students

### *Struggling students*

• Most students will not have difficulty with the pattern, but some may struggle with **part C**, where an explanation beyond the pattern is expected. You might use pictorial representations to help these students.

For example, show them a whole is represented by one 10-by-10 grid. Show how  $1 \div 0.1$  asks how many tenths are in the whole. The answer is  $1 \times 10$ . Then show how  $1 \div 0.01$  asks how many hundredths are in the whole. Now the answer is  $1 \times 100$ .

## 3.2.4 Dividing Decimals

Curriculum Outcomes		Outcome relevance
<b>6-B2 Estimation Strategies for Multiplication and Division: whole numbers and decimals</b> <ul style="list-style-type: none"> <li>• apply estimation strategies: rounding, front-end</li> </ul> <b>6-B7 Divide Decimals by Decimals: estimating and developing algorithms through reasoning</b> <ul style="list-style-type: none"> <li>• use meaningful strategies to calculate quotients of decimals</li> </ul>		<ul style="list-style-type: none"> <li>• Many real-word calculations, including the calculation of measurements, involve the division of two decimals.</li> <li>• The continued use of estimation will ensure that students can appropriately check their calculations.</li> </ul>
Pacing	Materials	Prerequisites
1.5 h	<ul style="list-style-type: none"> <li>• Hundredths Grids (BLM)</li> </ul>	<ul style="list-style-type: none"> <li>• dividing whole numbers</li> <li>• representing decimal tenths and decimal hundredths on a grid</li> </ul>

### Main Points to be Raised

- You can model decimal tenths or decimal hundredths using a hundredths grid.
- $a \div b$  means how many groups of  $b$  can fit into  $a$ .
- The quotient  $a \div b$  does not change if both numbers are multiplied by the same amount, for example, by 10, 100, or 1000.
- If you have a remainder when you divide by a decimal, you can use more decimal places or a fraction to describe it. You should also consider the remainder in terms of the divisor, not as a part of 1. For example, for  $3.3 \div 0.4$ , you get 8 groups of 0.4 with 0.1 left over. That 0.1 is one fourth of another group of 0.4, so the remainder is actually the decimal 0.25, not the decimal 0.1.

### Try This — Introducing the Lesson

A. Allow students to try this alone or with a partner. While you observe students at work, you might ask questions such as the following:

- *How did you estimate 3.6?* (I called it 4.)
- *How did you estimate 0.3?* (I used 0.5 and thought about it as one half.)
- *How did you calculate your estimate?* (I figured there are 2 halves in 1, so there are 8 halves in 4. I know that 0.5 is almost twice as much as 0.3, so I increased my estimate to 14.)

### The Exposition — Presenting the Main Ideas

- Ask students what  $30 \div 6$  means. Accept their answers until a student indicates that it tells how many 6s are in 30. Point out that, similarly,  $3 \div 0.6$  means “How many sixes are in 30?” Write that on the board.
- Turn students’ attention to **page 88** of the student text where a diagram shows what  $3 \div 0.6$  looks like and why the answer is 5. Tell students that if they had rewritten 3 as 30 tenths, they would have been asking “How many groups of 6 tenths are in 30 tenths?” and it would have been clear that the answer would be 5 groups.
- Point out another way they could think about the result. Think about dividing by 6 tenths as dividing first by one tenth and then by six (first find out how many 1 tenths are in the number and then group that amount into sixes). In this case,  $3 \div 0.1 = 3 \times 10 = 30$  and  $30 \div 6 = 5$ .
- Practice these ideas using  $3.2 \div 0.8$  to see if students realize why the result is 4.
- Present the question  $3.4 \div 0.8$ . Students should realize that the answer will be greater than 4 but less than 5. Draw a diagram so students can see that there are 4 whole groups of 0.8 and another 1 fourth of a group. For that reason, the result is 4.25 (not 4.2, as they might think at first). This is because the quotient tells how many groups of 0.8.
- Ask students to then look at the question in the exposition on **page 89**. Lead students through the discussion of  $2.5 \div 0.45$ .

- Finally, help students see why  $4 \div 2$ ,  $0.4 \div 0.2$ , and  $0.04 \div 0.02$  all have the same result. The number of 2s in 4 tells how many groups of 2 tenths are in 4 tenths or how many groups of 2 hundredths are in 4 hundredths.
- Point out that this means that if you are dividing by a decimal, you can multiply both the dividend and the divisor by tens to get rid of the decimal.

For example, rewrite  $3.6 \div 1.2$  as  $(3.6 \times 10) \div (1.2 \times 10) = 36 \div 12$ . You might support this by showing that if you think of  $4 \div 2 = \frac{4}{2}$ , then  $\frac{4}{2} = \frac{40}{20}$  ( $40 \div 20$ ) or  $\frac{400}{200}$  ( $400 \div 200$ ).

This approach allows you to always divide by a whole number instead of by a decimal.

- Practice this idea by renaming these dividends and divisors to result in the same quotient:

$$5.2 \div 0.7 \text{ (rename as } 52 \div 7)$$

$$5 \div 0.7 \text{ (rename as } 50 \div 7)$$

$$5 \div 0.25 \text{ (rename as } 500 \div 25)$$

## Revisiting the Try This

**B.** Students can use what they have learned about dividing by decimals to calculate  $3.6 \div 0.3$  as 12.

## Using the Examples

- Pose the problem from the example on the board. Have students try it with a partner and then compare their work with the solution and thinking in the student text.

## Practising and Applying

### Teaching points and tips

**Q 1:** Make sure students use hundredths grids for this question.

**Q 2:** Encourage students to rewrite the questions as equivalent divisions with a whole number divisor. Also encourage them to estimate to check their results.

**Q 3, 4, and 5:** Students will need to recognize these questions as division situations.

**Q 6:** This question requires students to think about what the operation means, not just about how to do it.

**Q 8:** This question is designed to help students avoid a common error people make when they divide decimals.

### Common errors

- Students sometimes have difficulty with questions like  $1.8 \div 0.15$ . Rather than changing the calculation to  $180 \div 15$ , many change it to  $18 \div 15$ . They use only the existing decimal places. Encourage students to estimate so they can avoid this problem.

### Suggested assessment questions from Practising and Applying

<b>Question 2</b>	to see if students can divide a decimal by a decimal
<b>Question 5</b>	to see if students can solve a contextual problem involving division by a decimal
<b>Question 9</b>	to see if students can communicate about the process for dividing by a decimal

## Answers

<b>A.</b> <i>Sample response:</i> About 14 packets	<b>B. i)</b> $3.6 \div 0.3 = 12$ <b>ii)</b> <i>Sample response:</i> $36 \div 3 = 12$
---	---

1. a) 3

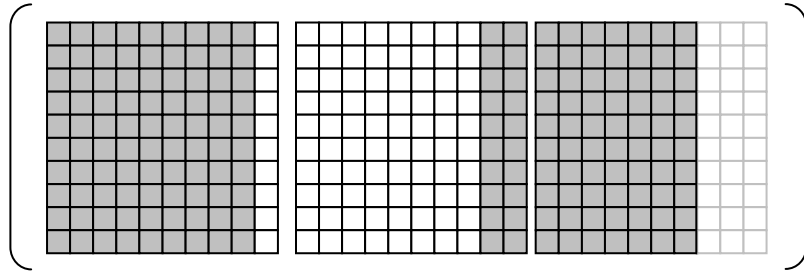

b) 2

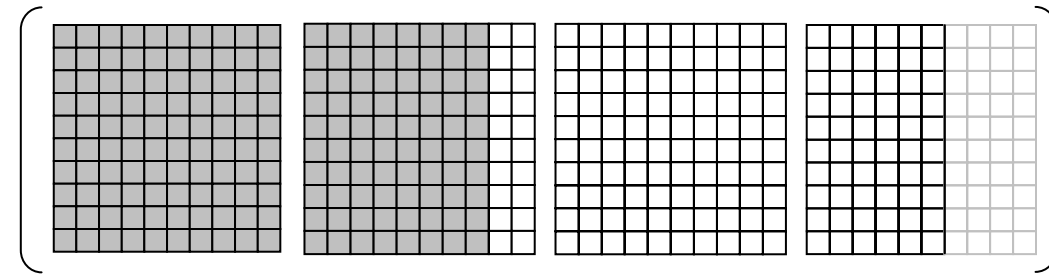

c) 7

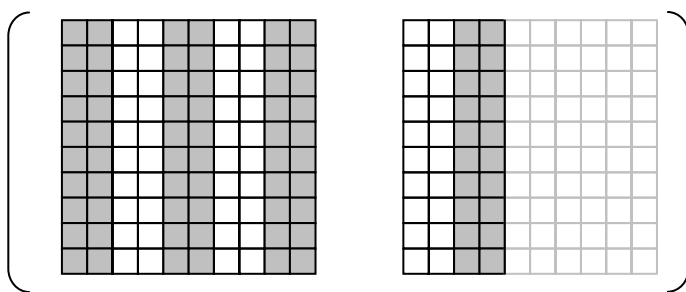

d) 3.75 (or  $3\frac{3}{4}$ )

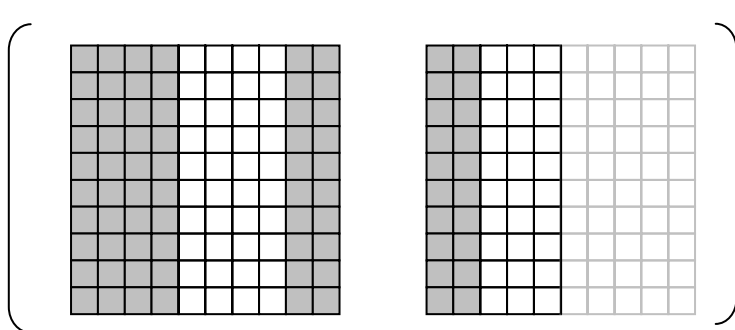

2. a) 30

b) 12.25

c) 4.5

d) 12

3. a) 14 pieces (with some left over)

b) 57

c) 19

d) 9 pieces (with some left over)

4. 104.972 km in 1 h

5. 5 glasses

[6. *Sample responses:*

a)  $1.2 \div 0.3$  is asking how many 3 tenths are in 12 tenths, which is how many 3s are in 12.

b)  $1.2 = 1.20 = 120$  hundredths;  $1.2 \div 0.03$  is asking how many 3 hundredths are in 120 hundredths, which is how many 3s are in 120.

c) 0.03 is 3 hundredths; 0.3 is 3 tenths; pieces of size 0.03 are one tenth the size of 0.3 pieces, so 10 times as many will fit in.]

## Answers [Continued]

<p><b>7.</b> Yes; [<i>Sample response:</i> He has multiplied the dividend and the divisor by the same amount, 100, so the quotient does not change. It is like dividing <math>4 \div 2</math> by dividing <math>(4 \times 2) \div (2 \times 2) = 8 \div 4</math>. The quotient is still 2.]</p>	<p><b>8.</b> No; [<i>Sample response:</i> It is incorrect because <math>3.2 \times 0.6 = 1.92</math> and not 2.0.]</p> <p>[<b>9.</b> <i>Sample response:</i> It means how many 0.02s are in 3.4. I would think of 0.02 as 2 hundredths and of 3.4 as 340 hundredths. Then I would divide 340 by 2 to get 170.]</p>
---	--

## Supporting Students

### *Struggling students*

- Struggling students may have difficulty with questions where there is a 2-digit divisor.

For example, for **question 3 d**), help students see that they might solve this by realizing that there are 2 groups of 1.25 in 2.5 and 4 groups of 1.25 in 5. They could then divide by 5 and multiply by 4.

- Draw attention to **question 8**. This is an example of a common error made by students who do not know how to handle a remainder. When they divide 20 by 6, the remainder is 2. That 2 represents 2 out of 6 (or 2 tenths out of 6 tenths) and not 0.2, which is 2 out of 10. Draw a diagram to help students see this.

### *Enrichment*

- Encourage students to create problems involving decimal division. They can trade their problems with other students and solve each other's problems.

## Chapter 3 Combining Operations

### 3.3.1 Order of Operations

Curriculum Outcomes	Outcome relevance
<p><b>6-B8 Addition and Subtraction of Decimals and Whole numbers: choosing most appropriate method</b></p> <ul style="list-style-type: none"> <li>choose among written, mental calculations, estimation as the most appropriate method</li> <li>regularly estimate when performing computations</li> <li>apply strategies: front-end estimation, compensation (e.g., <math>14.95 + 1.99 + 10.98 - 7.1 = 15 + 2 + 11 - 8 = 20</math>)</li> </ul> <p><b>6-B3 Multiply Decimals by Whole Numbers: pictorially, symbolically</b></p> <ul style="list-style-type: none"> <li>compute products of whole numbers using an algorithm</li> <li>know when to use a pencil/paper algorithm or a mental procedure</li> <li>regularly estimate when performing computations</li> </ul> <p><b>6-B4 Multiply Decimals by Decimals: concretely and symbolically</b></p> <ul style="list-style-type: none"> <li>use meaningful strategies to calculate products of decimals</li> <li>regularly estimate when performing computations</li> </ul> <p><b>6-B5 Whole Numbers and Decimals: single-digit division</b></p> <ul style="list-style-type: none"> <li>relate to whole number division</li> <li>link concrete models to algorithms</li> <li>regularly estimate when performing computations</li> </ul> <p><b>6-B7 Divide Decimals by Decimals: estimating and developing algorithms through reasoning</b></p> <ul style="list-style-type: none"> <li>use meaningful strategies to calculate quotients of decimals</li> </ul>	<p>Students need to be able to apply what they know about all four decimal operations to solve problems involving combinations of the operations.</p>

Pacing	Materials	Prerequisites
1 h	None	<ul style="list-style-type: none"> <li>adding, subtracting, multiplying, and dividing decimals</li> <li>familiarity with the order of operations for whole numbers</li> </ul>

#### Main Points to be Raised

- Some calculations that involve several operations result in different answers depending on the order in which the computations are done; sometimes the order does not matter.
- The order of operations has been agreed to be:
  - Do calculations in brackets first.
  - Perform all multiplications and divisions in order from left to right.
  - Perform all additions and subtractions in order from left to right.

#### Try This — Introducing the Lesson

A. Allow students to try this alone or with a partner. While you observe students at work, you might ask questions such as the following:

- Which computation did you do first? Why?* (I did  $3 \times 5.2$  because it came first.)
- What did you do next?* (I added 20.5 because it came next)
- How did you calculate  $3 \times 5.2$ ?* (I multiplied 3 by 5 and 3 by 0.2 and added the parts)

#### The Exposition — Presenting the Main Ideas

- Lead students through the exposition on **page 91** of the student text. You may wish to have students record the order of operations rules in their notebooks.
- Make sure students understand that the decision for this order is arbitrary; a different decision could have been made, but this is simply what people have agreed to so that everyone gets the same answer to a calculation.

## Revisiting the Try This

**B.** Students can examine the expression in **part A** to see why the order of operations rules are critical for knowing how to answer this in a consistent way.

### Using the Examples

- Have students read through the example and ask any questions they might have.

### Practising and Applying

#### Teaching points and tips

**Q 2 and 4:** These questions are designed so that students can see that sometimes brackets are necessary, but sometimes they are not because of the order of operations rules.

**Q 3:** This question provides the opportunity to see how verbal expressions are translated into calculations that respect the order of operations rules.

**Q 5:** This more challenging question requires students to try different operations to see how a particular result could have been obtained.

**Q 6:** This question allows students to summarize the knowledge they have gained about order of operations.

#### Common errors

- Some students are still tempted to perform calculations from left to right. Reinforce the need for consistency with the rules for the order of operations.

#### Suggested assessment questions from Practising and Applying

<b>Question 1</b>	to see if students can perform decimal calculations taking order of operations rules into account
<b>Question 3</b>	to see if students can translate a verbal expression of a calculation into symbols properly
<b>Question 4</b>	to see if students recognize whether brackets are needed to ensure that a calculation is performed as intended

### Answers

<b>A.</b> 56.6	<b>B. i)</b> They might have done the computations in order from left to right, or they might have first done the multiplication and division and then the addition. <b>ii)</b> 56.6
<p><b>1. a)</b> 9.1      <b>b)</b> 4.4 <b>c)</b> 4.4      <b>d)</b> 7</p> <p><b>2.</b> A and B</p> <p><b>3.</b> <math>(3.5 + 6.5) \div 0.2 + 4.2</math>; The answer is 54.2.</p> <p><b>4.</b> A, C, and D</p> <p><b>5. a)</b> <math>1.2 \div 3 \div 2 = 0.2</math> <b>b)</b> <math>1 \div (3 \times 3 \div 1) = 0.1</math></p>	<p><b>6. a) Sample responses:</b> <b>i)</b> 18.1;  <math>[6 + (12.5 + 5) \times 4 \div 5</math>  <math>= 6 + 17.5 \times 4 \div 5</math>      Do 6 + 17.5 before multiplying by 4.  <math>= 23.5 \times 4 \div 5</math>  <math>= 94 \div 5</math>  <math>= 18.8]</math></p> <p>13.4;  <math>[6 + (12.5 + 5) \times 4 \div 5</math>  <math>= 6 + 17.5 \times 4 \div 5</math>  <math>= 6 + 70 \div 5</math>      Do 6 + 70 before dividing by 5.  <math>= 76 \div 5</math>  <math>= 15.2]</math></p>



<p><b>ii) 0.23;</b>  <math>[2.2 - 0.9 \times 0.2 - 0.03</math>  <math>= 1.3 \times 0.2 - 0.03</math>  <math>= 0.26 - 0.03</math>  <math>= 0.23]</math></p> <p>0.67;  <math>[2.2 - 0.9 \times 0.2 - 0.03</math>  <math>= 2.2 - 0.9 \times 0.17</math>  <math>= 2.2 - 0.153</math>  <math>= 2.047]</math></p>	<p>Do <math>2.2 - 0.9</math> before multiplying by 0.2.</p> <p>Do <math>0.2 - 0.003</math> before multiplying by 0.9.</p>	<p><b>b)</b>  <b>i) 20;</b>  <math>[6 + (17.5 \times 4) \div 5</math>  <math>= 6 + (70 \div 5)</math>  <math>= 6 + 14</math>  <math>= 20]</math></p> <p><b>ii) 1.99;</b>  <math>[2.2 - 0.9 \times 0.2 - 0.03</math>  <math>= 2.2 - 0.18 - 0.03</math>  <math>= 2.02 - 0.03</math>  <math>= 1.99]</math></p>
---	---	---

## Supporting Students

### *Struggling students*

- Some students may have difficulty with **question 5**. You may choose not to assign this question to these students.

### *Enrichment*

- Ask students to create other questions like **question 5** for classmates to solve.

### 3.3.2 Solving a Problem Using all Four Operations

Curriculum Outcomes	Outcome relevance
<p><b>6-B8 Addition and Subtraction of Decimals and Whole numbers: choosing most appropriate method</b></p> <ul style="list-style-type: none"> <li>choose among written, mental calculations, estimation as the most appropriate method</li> <li>regularly estimate when performing computations</li> <li>apply strategies: front-end estimation, compensation (e.g., <math>14.95 + 1.99 + 10.98 - 7.1 = 15 + 2 + 11 - 8 = 20</math>)</li> </ul> <p><b>6-B3 Multiply Decimals by Whole Numbers: pictorially, symbolically</b></p> <ul style="list-style-type: none"> <li>compute products of whole numbers using an algorithm</li> <li>know when to use a pencil/paper algorithm or a mental procedure</li> <li>regularly estimate when performing computations</li> </ul> <p><b>6-B4 Multiply Decimals by Decimals: concretely and symbolically</b></p> <ul style="list-style-type: none"> <li>use meaningful strategies to calculate products of decimals</li> <li>regularly estimate when performing computations</li> </ul> <p><b>6-B5 Whole Numbers and Decimals: single-digit division</b></p> <ul style="list-style-type: none"> <li>relate to whole number division</li> <li>link concrete models to algorithms</li> <li>regularly estimate when performing computations</li> </ul> <p><b>6-B7 Divide Decimals by Decimals: estimating and developing algorithms through reasoning</b></p> <ul style="list-style-type: none"> <li>use meaningful strategies to calculate quotients of decimals</li> </ul>	<p>Students need to be able to apply what they know about all four decimal operations to solve problems.</p>

Pacing	Materials	Prerequisites
1 h	None	<ul style="list-style-type: none"> <li>adding, subtracting, multiplying, and dividing decimals</li> </ul>

#### Main Points to be Raised

- Problems involving decimal operations need to be analysed in terms of which operations are required and in what order.

#### Try This — Introducing the Lesson

**A.** Allow students to try this alone or with a partner. While you observe students at work, you might ask questions such as the following:

- What did you do first? Why?* (I first divided 8 by 0.4 to see how many hair bands I could make with 8 m.)
- Why did you need to do two divisions, but only one subtraction?* (I had to do two divisions to find out how many hair bands and how many bracelets I could make. Then I only needed one subtraction to see how much more one was than the other.)

#### The Exposition — Presenting the Main Ideas

- On the board write the problem from the exposition on **page 93** of the student text. Ask students which operations are necessary and why. Have them work in pairs to solve the problem.
- Then lead students through the exposition to help them see one strategy for solving the problem. Have them compare this strategy to the strategy they used.

#### Revisiting the Try This

**B.** Students can use what they learned in this exposition and in the exposition from the previous lesson to answer this question.

## Using the Examples

- Have students work in pairs to read through the example. Talk about the idea that you can often use a diagram to help you solve a problem. You might then ask students if they have any questions about the solution.

## Practising and Applying

### Teaching points and tips

**Q 1:** Some students may have difficulty deciding how to use the three numbers in the problem. Ask them how heavy a 16 cm piece of wire would be, then a 24 cm piece, and finally an 80 cm piece. Ask how this information might help them estimate the answer to the question.

**Q 2:** Encourage students to draw a diagram to show the information in the table.

**Q 3:** Make sure students understand that the area of the strip is not included in the fabric that is divided.

**Q 4:** You may have to explain interest to some students.

**Q 5:** Notice that only an estimate is required, so there are many possible responses.

**Q 6:** If students have difficulty creating a problem, encourage them to use as a model one of the earlier problems in the exercises.

### Suggested assessment questions from Practising and Applying

<b>Question 2</b>	to see if students can translate information from a table to solve a problem involving decimals
<b>Question 3</b>	to see if students can use a diagram to help them solve a problem involving decimals
<b>Question 5</b>	to see if students can solve a multi-step problem involving decimals

## Answers

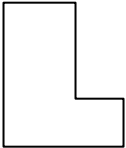
<b>A.</b> 12 more	<b>B. Sample responses:</b> i) I divided and subtracted. ii) I first did two divisions and then subtracted.
<p><b>1.</b> 152.8 cm [<math>57.3 \div 3</math> is about <math>57 \div 3 = 19</math>; <math>19 \times 8 = 172</math>]</p> <p><b>2.</b> About 25 babies [<math>33.58 - 20.7 = 12.88</math>; <math>12.88 \div 0.5</math> is about <math>12.5 \div 0.5 = 25</math>]</p> <p><b>3. a)</b> <math>0.38 \text{ m}^2</math> [<math>1.2 - 0.4 = 0.8</math>; <math>0.8 \times 3.8 \div 8 = 0.1 \times 3.8 = 0.38</math>] <b>b)</b> <math>1.52 \text{ m}^2</math> [<math>0.4 \times 3.8 = 1.52</math>]</p> <p><b>4.</b> About Nu 1.80 [<math>443.37 - 432.56 = 10.81</math>; <math>10.81 \div 6</math> is a bit more than 1.8.]</p> <p><b>5.</b> 7.8 km every day except the last day, when they travelled 4.8 km [<math>67.2 + 3 = 70.2</math>; <math>70.2 \div 9 = 7.8</math>]</p>	<p><b>6. Sample response:</b> A room is shaped like an L. The small square on the end has an area of <math>3 \text{ m}^2</math>. The length and the width of the other part of the room are 3.5 m and 2.6 m. What is the total area of the room? (<math>12.1 \text{ m}^2</math>)</p>  <p><b>[7. Sample response:</b> I chose question 2. I first subtracted the two whale lengths to figure out how much longer the blue whale is than the sperm whale. Then I divided the difference by the length of the baby, 0.5, to figure out how many 0.5s would fit into that extra length.]</p>

## Supporting Students

### Struggling students

- Struggling students may have difficulty with **question 5**. Encourage them to draw a diagram.

For example, they could use a square to represent the distance for each of the 8 days, and a smaller square to represent the distance on the last day.

### Enrichment

- Students might extend **question 6** to create a greater variety of problems. They might also create problems requiring subtraction and/or division of decimals.

## CONNECTIONS: Decimal Magic Squares

- Students have met Magic Squares before. This particular Connection allows them to practise decimal computations, but it also lets them see how other Magic Squares can be created (by performing the same operation, whether with a whole number or with a decimal, on all the values in the square).
- This exercise reminds students indirectly about the distributive property for numbers:  $a(b + c) = ab + ac$ .

1. 3.4

2. Yes; 34

3. Yes; 3.74

# UNIT 3 Revision

Pacing	Materials
2 h	<ul style="list-style-type: none"> <li>• Place Value Charts I (BLM)</li> <li>• Hundredths Grids (BLM) (optional)</li> </ul>

Question(s)	Related Lesson(s)
1 – 3	Lesson 3.1.1
4 – 6	Lesson 3.1.2
7 – 10	Lesson 3.1.3
11 and 12	Lesson 3.2.1
13 – 15	Lesson 3.2.2
16	Lesson 3.2.3
17 – 19	Lesson 3.2.4
20 – 22	Lesson 3.3.1
23 and 24	Lesson 3.3.2

## Revision Tips

**Q 2:** Students need to realize that distance is calculated by multiplying speed by time.

**Q 6:** Students could use proportional thinking to solve this. Instead of dividing by 5 and then multiplying by 25, they can think of 25 people as 5 groups of 5 and then multiply 0.625 by 5.

**Q 14:** You might remind students they can divide in two steps, by 10 and by the appropriate multiple of 10 for that divisor.

**Q 16:** The explanation should not simply be a calculation; it should say why the calculations result in the same value.

## Answers

<p><b>1. Sample responses:</b></p> <p><b>a)</b> about 6 days [<math>150 \div 25 = 6</math>]</p> <p><b>b)</b> about 9000 min [<math>60 \times 150 = 9000</math>]</p>	<p><b>2. Sample responses:</b></p> <p><b>a)</b> about 69 km [<math>3 \times 23 = 69</math>]</p> <p><b>b)</b> about 250 km [<math>10 \times 25 = 250</math> km]</p> <p><b>c)</b> about 18 km [<math>6 \times 3 = 18</math> km]</p> <p><b>3.</b> B and C</p>																																																		
<p><b>4. a)</b></p> <table border="1" style="margin-left: 20px;"> <thead> <tr> <th>Tens</th> <th>Ones</th> <th>Tenths</th> <th>Hundredths</th> <th>Thousandths</th> </tr> </thead> <tbody> <tr> <td></td> <td>7</td> <td>1</td> <td>2</td> <td>5</td> </tr> <tr> <td></td> <td><math>5 \times 7</math></td> <td><math>5 \times 1</math></td> <td><math>5 \times 2</math></td> <td><math>5 \times 5</math></td> </tr> <tr> <td></td> <td>35</td> <td>5</td> <td>10</td> <td>25</td> </tr> <tr> <td>3</td> <td>5</td> <td>6</td> <td>2</td> <td>5</td> </tr> </tbody> </table>	Tens	Ones	Tenths	Hundredths	Thousandths		7	1	2	5		$5 \times 7$	$5 \times 1$	$5 \times 2$	$5 \times 5$		35	5	10	25	3	5	6	2	5	<p><b>b)</b></p> <table border="1" style="margin-left: 20px;"> <thead> <tr> <th>Tens</th> <th>Ones</th> <th>Tenths</th> <th>Hundredths</th> <th>Thousandths</th> </tr> </thead> <tbody> <tr> <td>1</td> <td>2</td> <td>2</td> <td>1</td> <td>9</td> </tr> <tr> <td><math>8 \times 1</math></td> <td><math>8 \times 2</math></td> <td><math>8 \times 2</math></td> <td><math>8 \times 1</math></td> <td><math>8 \times 9</math></td> </tr> <tr> <td>8</td> <td>16</td> <td>16</td> <td>8</td> <td>72</td> </tr> <tr> <td>9</td> <td>7</td> <td>7</td> <td>5</td> <td>2</td> </tr> </tbody> </table>	Tens	Ones	Tenths	Hundredths	Thousandths	1	2	2	1	9	$8 \times 1$	$8 \times 2$	$8 \times 2$	$8 \times 1$	$8 \times 9$	8	16	16	8	72	9	7	7	5	2
Tens	Ones	Tenths	Hundredths	Thousandths																																															
	7	1	2	5																																															
	$5 \times 7$	$5 \times 1$	$5 \times 2$	$5 \times 5$																																															
	35	5	10	25																																															
3	5	6	2	5																																															
Tens	Ones	Tenths	Hundredths	Thousandths																																															
1	2	2	1	9																																															
$8 \times 1$	$8 \times 2$	$8 \times 2$	$8 \times 1$	$8 \times 9$																																															
8	16	16	8	72																																															
9	7	7	5	2																																															
<p><b>5. a)</b> 35.6      <b>b)</b> 1720.4</p> <p><b>c)</b> 1119      <b>d)</b> 4872</p> <p><b>6.</b> 3.125 kg</p>	<p><b>7. a) i)</b> 0.28      <b>ii)</b> 0.16      <b>iii)</b> 1.19      <b>iv)</b> 6.72</p> <p><b>[b)</b> <math>0.4 \times 0.7</math>; <i>Sample response:</i></p> <ul style="list-style-type: none"> <li>• I could draw a rectangle that is 0.4 by 0.7 inside a hundredths grid.</li> <li>• I could multiply 4 tenths by 7 tenths to get 28 hundredths and then change that to 2.8.]</li> </ul>																																																		

**Answers [Continued]**

<b>8. a)</b> 38.22 <b>b)</b> 92.5 <b>c)</b> 34.92 <b>d)</b> 283.92	<b>15.</b> 123.4 g
<b>9.</b> 1333.2 km	<b>[16. Sample response:</b> There are 10 sets of 0.1 in each whole, so there are $10 \times 3.2$ of 0.1 sets in 3.2.]
<b>10. Sample response:</b> $79 \times 0.4$	<b>17. a)</b> 190 <b>b)</b> 9.1 <b>c)</b> 15 <b>d)</b> 19.6
<b>11. Sample responses:</b> <b>a)</b> about 32 kilometres in 1 h [ $16 \div 0.5 = 32$ ] <b>b)</b> about 28 kilometres in 1 h [ $56 \div 2 = 28$ ] <b>c)</b> about 25 32 kilometres in 1 h [ $125 \div 5 = 25$ ]	<b>18.</b> About 7
<b>12.</b> B and D	<b>19. Sample response:</b> $42 \div 7$ , $420 \div 70$ , $4200 \div 700$
<b>13. a)</b> 0.32 <b>b)</b> 1.426 <b>c)</b> 0.237 <b>d)</b> 0.491	<b>20. a)</b> 11.5 <b>b)</b> 21 <b>c)</b> 1.77
<b>14. a) i)</b> 1.44 <b>ii)</b> 6.048 <b>iii)</b> 2.53 <b>iv)</b> 6.98 <b>[b) Sample response:</b> I checked b) and c). b) I multiplied $50 \times 6.048$ by multiplying by 100 and dividing by 2: $604.8 \div 2 = 302.4$ . c) I multiplied $70 \times 2.53$ and got 177.1.]	<b>21.</b> B and C
	<b>22. a)</b> $(13.5 \pm 1.5) \times 2 = 30$ <b>b)</b> $(10 \pm 2) \times 1.2 = 9 = 5.4$
	<b>23.</b> 8.8 km
	<b>24.</b> 0.76 m [ $1.72 \times 0.75 = 1.29$ ; $1.29 - 0.53 = 0.76$ ]

## UNIT 3 Decimal Computation Test

1. Estimate.

- a)  $4 \times 23.87$       b)  $60 \times 2.89$   
c)  $0.7 \times 48.1$       d)  $32.5 \times 47.3$

2. Multiply.

- a)  $8 \times 12.96$       b)  $7 \times 148.3$   
c)  $30 \times 5.8$       d)  $200 \times 41.32$

3. Estimate to decide where to put the decimal point in each product.

- a)  $4.3 \times 15.23 = 65489$   
b)  $8.8 \times 13.4 = 11792$

4. Use a hundredths grid to model each and then find each answer.

- a)  $0.3 \times 0.8$   
b)  $3.9 \div 1.3$   
c)  $2.8 \div 0.5$

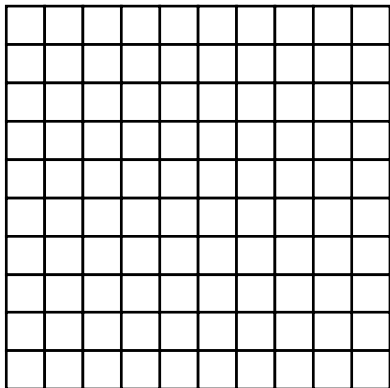

5. Estimate to decide where to put the decimal point in each quotient.

- a)  $74.34 \div 6.3 = 118$   
b)  $49 \div 0.25 = 19600$

6. Calculate each mentally.

- a)  $3.56 \times 100$       b)  $42.38 \times 1000$   
c)  $45.3 \div 10$       d)  $128 \div 100$   
e)  $5.28 \div 0.1$       f)  $34.26 \div 0.01$

7. Divide.

- a)  $45.6 \div 0.8$       b)  $11.07 \div 0.9$   
c)  $3.75 \div 0.25$       d)  $417.5 \div 0.2$

8. Calculate.

- a)  $4.5 + 3.5 \div 0.7 - 0.5$   
b)  $8 \times (2.9 + 5.1) - 4.1 \times 2$

9. Lemo walked 5.2 km in 1 h.

Dorji walked 4.8 km in 1 h.

Suppose both boys kept walking at his same pace.

- a) How far would Lemo walk in 3.5 h?  
b) How long would it take Dorji to walk 21.6 km?  
c) How much farther would Lemo walk than Dorji in 6.6 h?

10. Five bags of rice are each 152 g.

- a) What fraction of a kilogram is all the rice combined?  
b) If the rice were combined and then put into eight small packets, how many grams of rice would be in each small packet?  
c) How many 0.25 kg packets could be made with all of the rice?

11. What number is missing from each equation?

- a)  $3.4 + \square \div 0.6 = 5.4$   
b)  $18 - 12.8 \div \square \times 4 = 11.6$

12. Write a word problem that could be solved by multiplying and dividing decimals. Solve your problem.

# UNIT 3 Test

Pacing	Materials
1 h	<ul style="list-style-type: none"> <li>• Place Value Charts I (BLM)</li> <li>• Hundredths Grids (BLM) (optional)</li> </ul>

Question(s)	Related Lesson(s)
1	Lesson 3.1.1
2	Lesson 3.1.2
3	Lesson 3.1.3
4	Lessons 3.1.3 and 3.2.4
5	Lesson 3.2.1
6	Lessons 3.1.2, 3.2.2, and 3.2.3
7	Lesson 3.2.4
8	Lesson 3.3.1
9	Lessons 3.1.3, 3.2.4, and 3.3.2
10	Lessons 3.1.2 and 3.2.2
11	Lesson 3.3.1
12	Lesson 3.3.2

Select questions to assign according to the time available.

## Answers

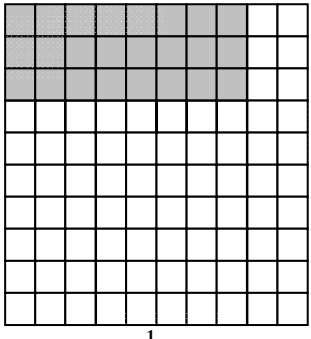
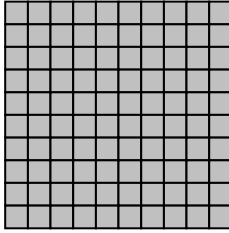
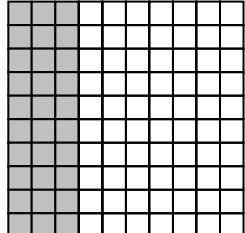
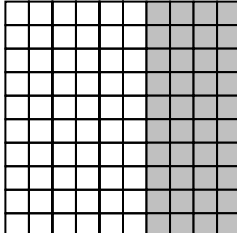
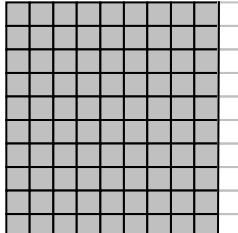
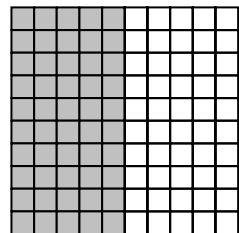
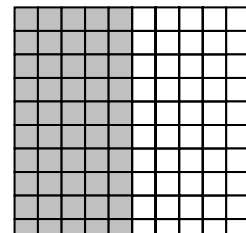
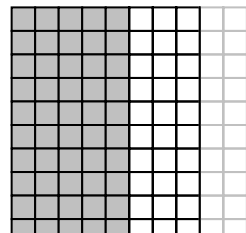
<p><b>1. Sample responses:</b></p> <p><b>a)</b> 100 [<math>4 \times 25</math>]      <b>b)</b> 180 [<math>60 \times 3</math>]  <b>c)</b> 40 [less than <math>1 \times 48</math>]      <b>d)</b> 1500 [<math>30 \times 50</math>]</p> <p><b>2. a)</b> 103.68      <b>b)</b> 1038.1  <b>c)</b> 174      <b>d)</b> 8264</p> <p><b>3. a)</b> 65.489      <b>b)</b> 117.92</p>	<p><b>4. a)</b> 0.24      0.8</p> <div style="display: flex; align-items: center;"> <div style="margin-right: 10px;">0.3</div>  </div>
<p><b>4. b)</b> 3</p> <div style="display: flex; justify-content: space-around;">     </div>	
<p><b>c)</b> 5.6</p> <div style="display: flex; justify-content: space-around;">    </div>	



<b>5. a)</b> 11.8	<b>b)</b> 196.00		<b>10. a)</b> 0.76 kg
<b>6. a)</b> 356	<b>b)</b> 42,380	<b>c)</b> 4.53	<b>b)</b> 95 g
<b>d)</b> 1.28	<b>e)</b> 52.8	<b>f)</b> 3426	<b>c)</b> 3 packets, with 10 g of rice left over
<b>7. a)</b> 57	<b>b)</b> 12.3		<b>11. a)</b> 1.2 <b>b)</b> 8
<b>c)</b> 15	<b>d)</b> 2087.5		<b>12. Sample response:</b>
<b>8. a)</b> 9	<b>b)</b> 55.8		A piece of fabric is 3.2 m long and 1.5 m wide.
<b>9. a)</b> 18.2 km	<b>b)</b> 4.5 h	<b>c)</b> 2.64 km	<b>a)</b> What is the area of the fabric?
			<b>b)</b> If the fabric were divided into 4 equal pieces, what would be the area of each piece?
			<b>(a)</b> 4.8 m <sup>2</sup> <b>b)</b> 1.2 m <sup>2</sup> )

## UNIT 3 Performance Task — Container Capacities

Here are three containers:

The sink holds 10.6 L.

The pail holds 15.9 L.

The bowl holds 0.35 L.



**A.** Suppose you filled each container with water twice and then emptied the contents into a large tub. How much water would be in the tub?

**B.** Suppose you filled each container until it was 0.9 full. How many litres of water would be in each?

**i)** the sink            **ii)** the pail            **iii)** the bowl

**C. i)** Suppose you filled the sink and then divided the water equally into 4 smaller containers. How much would be in each small container?

**ii)** Suppose you filled the pail and then divided the water equally into 4 smaller containers. How much would be in each small container?

**D.** How many times would you have to fill the sink to have the same amount of water as the pail holds?

**E.** About how many times would you have to fill each container to have 31.8 L of water? Show how you estimated.

**i)** the sink            **ii)** the pail            **iii)** the bowl

**F.** How does your answer to **part D** explain your answer to **part E ii)**?

**G.** Write two word problems about filling or emptying the containers.

- At least one of the problems must involve multiplication.
- At least one of the problems must involve division.
- At least one of the problems must involve estimating.

Solve your problems.

## UNIT 3 Performance Task

Curriculum Outcomes Assessed	Pacing	Materials
<b>6-B8</b> Addition and Subtraction of Decimals and Whole Numbers: choosing most appropriate method <b>6-B3</b> Multiply Decimals by Whole Numbers: pictorially, symbolically <b>6-B4</b> Multiply Decimals by Decimals: concretely and symbolically <b>6-B5</b> Whole Numbers and Decimals: single-digit division <b>6-B7</b> Divide Decimals by Decimals: estimating and developing algorithms through reasoning	1 h	<ul style="list-style-type: none"> <li>• Hundredths Grids (BLM) (optional)</li> <li>• Place Value Charts I (BLM) (optional)</li> </ul>

### How to Use This Performance Task

- You might use this task as a rich problem to assess student understanding of a number of outcomes in this unit. It could replace or supplement the unit test. It could also be used as enrichment material for some students.
- You can assess performance on the task using the rubric on the next page.

### Sample Solution

<p><b>A.</b> 53.7 L</p> <p><b>B. i)</b> 9.54 L    <b>ii)</b> 14.31 L    <b>iii)</b> 0.315 L</p> <p><b>C. i)</b> 2.65 L    <b>ii)</b> 3.975 L</p> <p><b>D.</b> 1.5 times</p> <p><b>E. i)</b> About 3 times; <math>31.8 \div 10.6</math> is about <math>33 \div 11 = 3</math>.  <b>ii)</b> About 2 times; <math>31.8 \div 15.9</math> is about <math>30 \div 15 = 2</math>.  <b>iii)</b> About 80 times; <math>31.8 \div 0.35</math> is about <math>40 \div 0.5 = 80</math>.</p>	<p><b>F.</b> The pail holds 1.5 times as much as the sink and <math>1.5 = \frac{3}{2}</math>, so it makes sense that it takes 3 sinks of water, but only 2 pails of water, to get 31.8 L.</p> <p><b>G.</b></p> <ul style="list-style-type: none"> <li>• I filled the sink twice and the pail once. How much water do I have? (37.1 L)</li> <li>• I need about 2.5 L of water. About how many times would I have to fill the bowl to get that much? (About 7 times)</li> </ul>
--	---

### UNIT 3 Performance Task Assessment Rubric

<i>The student</i>	Level 4	Level 3	Level 2	Level 1
<b>Calculates with whole numbers and decimals</b>	Shows completely correct calculations for multiplying and dividing whole numbers by decimals	Shows mostly correct calculations, with minor errors in one or two of the operations	Shows many correct calculations, with some errors	Shows errors in most calculations
<b>Calculates with two decimals</b>	Shows completely correct calculations for multiplying and dividing decimals	Shows mostly correct calculations, with minor errors in one or two of the operations	Shows many correct calculations, with some errors	Shows errors in most calculations
<b>Creates and solves problems involving decimals</b>	Insightfully solves problems requiring decimal multiplication, division, and estimation; creates interesting and appropriate problems involving those operations	Solves most problems requiring decimal multiplication, division, and estimation; creates appropriate problems involving those operations	Solves some problems requiring decimal multiplication, division, and estimation; creates at least one appropriate problem involving those operations	Has difficulty solving and/or creating problems requiring decimal multiplication, division, and estimation

# UNIT 3 Blackline Masters

## BLM 1 Place Value Charts I

Tens	Ones	Tenths	Hundredths	Thousandths

Tens	Ones	Tenths	Hundredths	Thousandths

Tens	Ones	Tenths	Hundredths	Thousandths

Tens	Ones	Tenths	Hundredths	Thousandths

Tens	Ones	Tenths	Hundredths	Thousandths

Tens	Ones	Tenths	Hundredths	Thousandths

Tens	Ones	Tenths	Hundredths	Thousandths

Tens	Ones	Tenths	Hundredths	Thousandths

**BLM 2A Base Ten Models (Hundreds, Tens, and Ones)**

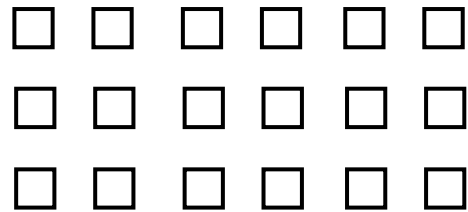
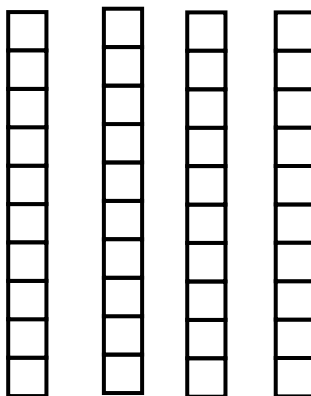
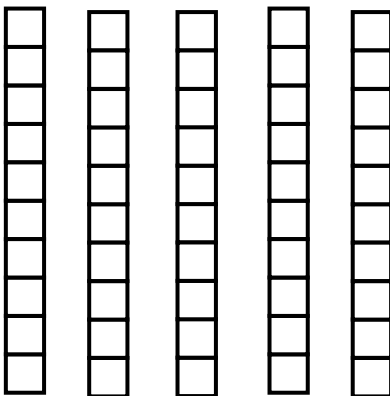
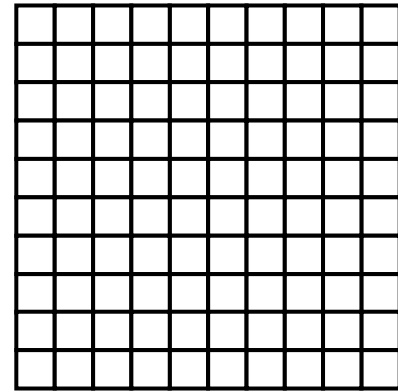
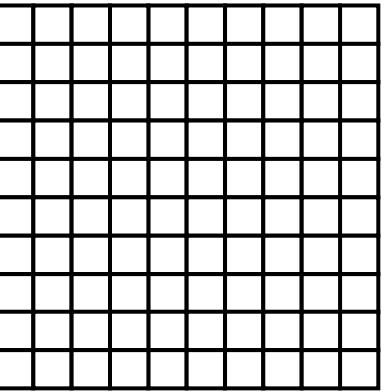
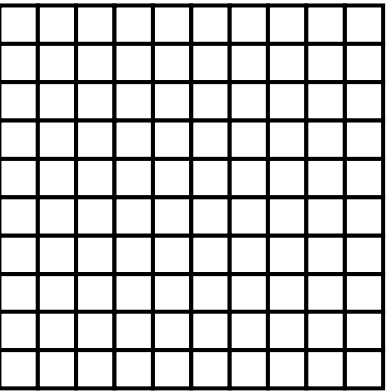
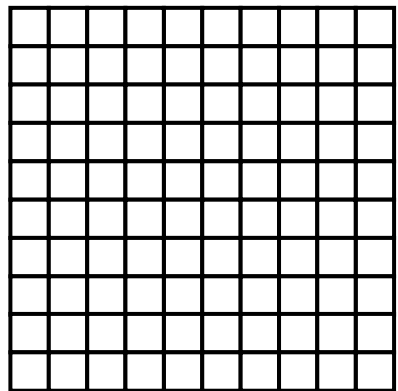
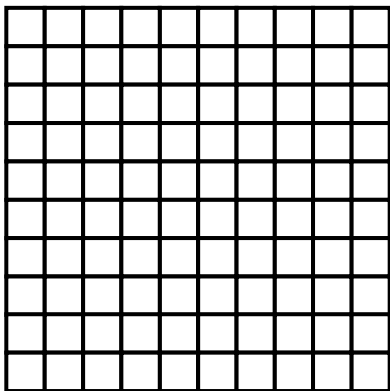
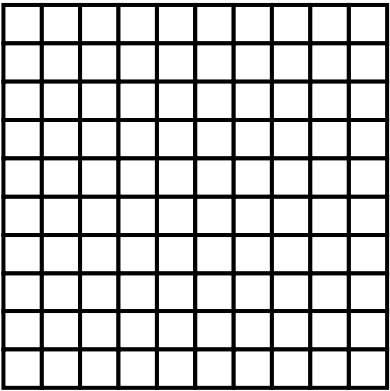
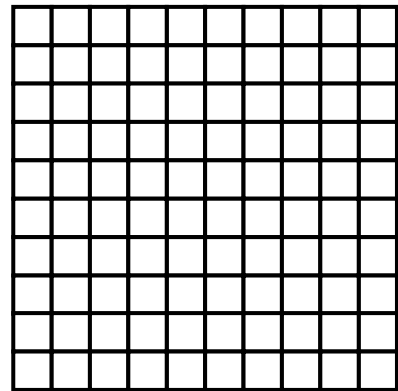
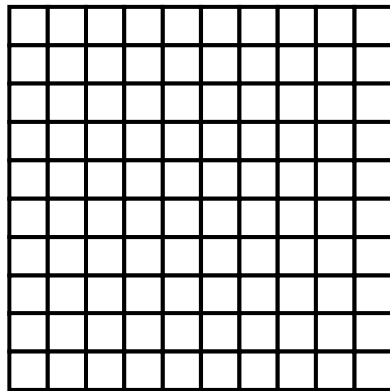
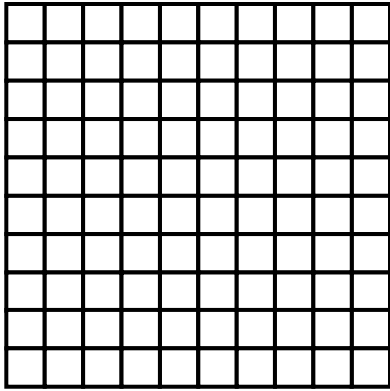

**BLM 2B Base Ten Models (Thousands)**

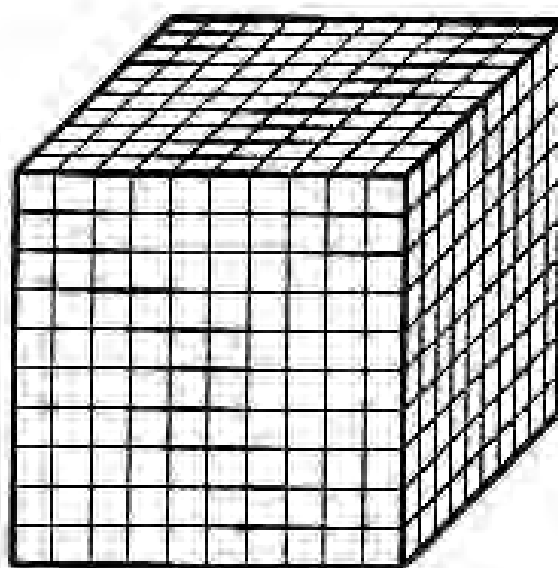
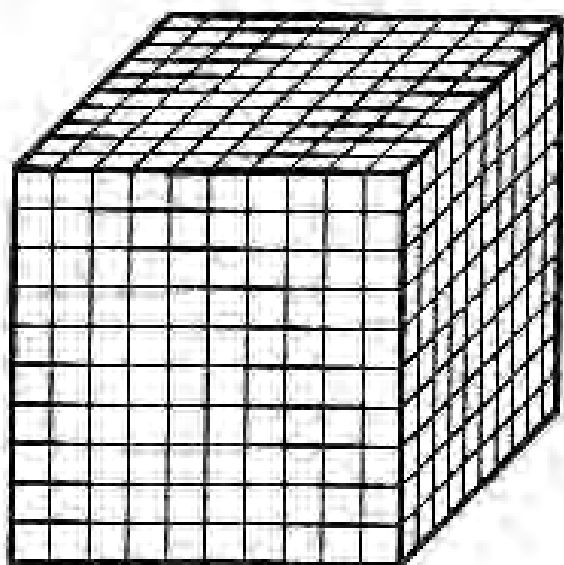
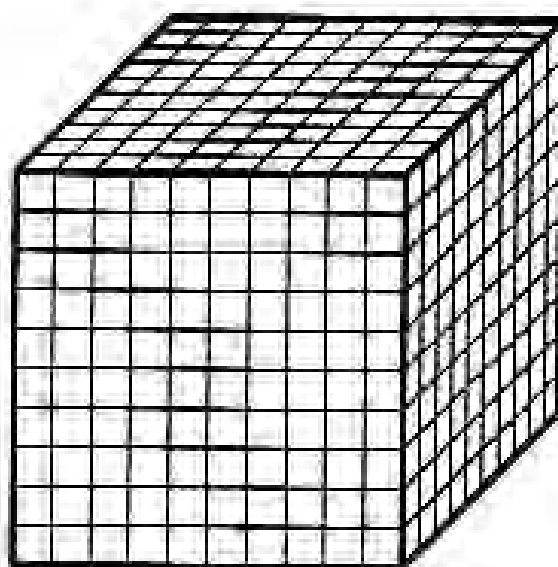
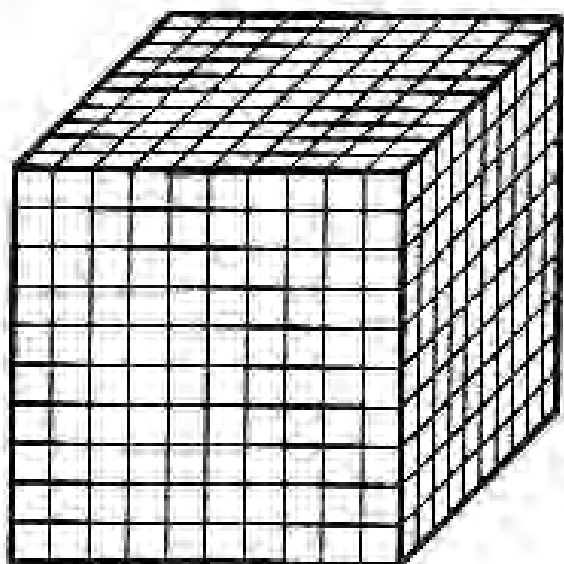
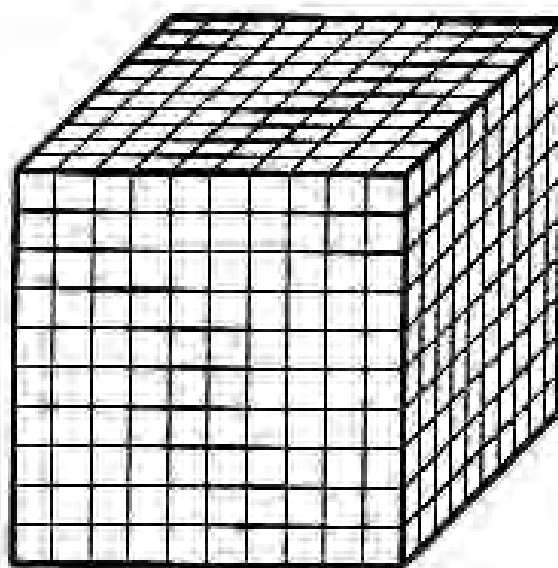
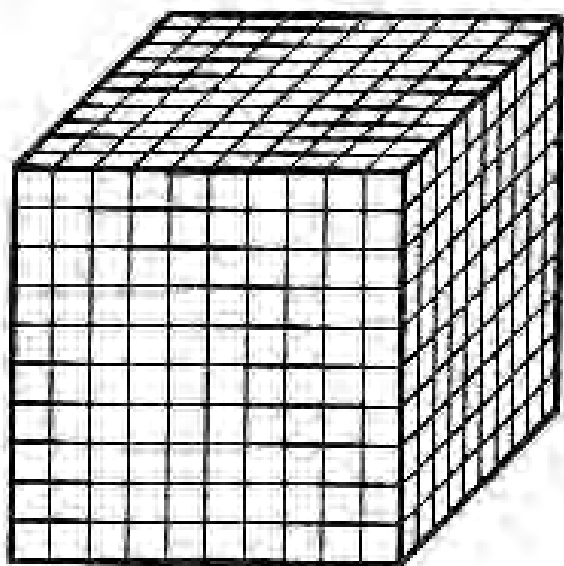

# UNIT 4 MEASUREMENT

## UNIT 4 PLANNING CHART

	Outcomes or Purpose	Suggested Pacing	Materials	Suggested Assessment
Getting Started SB p. 99 TG p. 150	Review prerequisite concepts, skills, and terminology and pre-assessment	1 h	• Rulers (optional)	All questions
<b>Chapter 1 Area</b>				
4.1.1 Area of a Parallelogram SB p. 101 TG p. 152	<b>6-D1 Area: calculate to solve problems</b> <ul style="list-style-type: none"> <li>• calculate area in <math>\text{cm}^2</math>, <math>\text{m}^2</math>, <math>\text{km}^2</math></li> <li>• choose appropriate units for situations</li> </ul> <b>6-D2 Parallelograms: relate bases, heights, and areas</b> <ul style="list-style-type: none"> <li>• understand that the area of a parallelogram is the same as the area of a rectangle with the same base and height</li> <li>• determine the base or height, given the area and the other dimension</li> <li>• understand that a variety of parallelograms can have the same area</li> </ul>	1 h	• Paper parallelogram • Scissors	Q1, 3, 4
CONNECTIONS: Changing a Parallelogram (Optional) SB p. 105 TG p. 155	Make a connection between the formula for the area of a parallelogram and the base and height of the shape	30 min	• Cardboard strips (2 of 15 cm and 2 of 8 cm) • Fasteners or string	N/A
4.1.2 Area of a Triangle SB p. 106 TG p. 156	<b>6-D1 Area: calculate to solve problems</b> <ul style="list-style-type: none"> <li>• calculate area in <math>\text{cm}^2</math>, <math>\text{m}^2</math>, <math>\text{km}^2</math></li> </ul> <b>6-D3 Area of a Triangle: relate to area of a parallelogram</b> <ul style="list-style-type: none"> <li>• understand that any triangle is one half of a parallelogram</li> <li>• understand that the area of a triangle is half the area of the parallelogram with the same base and height</li> <li>• understand that the areas of different triangles are equal if their bases and heights are equal</li> </ul>	1 h	• Square Dot Grid Paper (BLM) • Two congruent paper triangles	Q1, 3, 5, 7
GAME: Grid Fill (Optional) SB p. 110 TG p. 158	Practise calculating areas of triangles and parallelograms in a game situation	20 min	• Square Dot Grid Paper (BLM) • Dice	N/A
4.1.3 EXPLORE: Relating Areas (Essential) SB p. 111 TG p. 159	<b>6-C4 Area Patterns: explore</b> <ul style="list-style-type: none"> <li>• represent symbolically changes in area based on changes in linear dimensions (e.g., parallelograms: <math>A = bh</math> so if <math>b</math> and <math>h</math> are both doubled, area is quadrupled; if <math>b</math> is doubled but <math>h</math> is halved the area remains the same)</li> </ul> <b>6-D4 SI Units: Relationships</b> <ul style="list-style-type: none"> <li>• investigate the relationship between linear SI units and the relationship between corresponding SI area units</li> </ul>	1 h	None	Observe and Assess questions

## UNIT 4 PLANNING CHART [Continued]

	Outcomes or Purpose	Suggested Pacing	Materials	Suggested Assessment
<b>Chapter 2 Volume</b>				
<b>4.2.1</b> Volume of a Rectangular Prism <b>SB p. 113</b> <b>TG p. 162</b>	<b>6-C3 Volume Patterns: explore</b> • explore how a change in one dimension of affects the volume of a rectangular prism and relate this to the volume formula, $V = l \times w \times h$ <b>6-D4 SI Units: Relationships</b> • investigate the relationship between linear SI units and the relationship between corresponding SI volume units	1 h	• Linking cubes	Q1, 2, 4, 7
<b>4.2.2</b> Relating Volume to Capacity <b>SB p. 118</b> <b>TG p. 165</b>	<b>6-D5 Volume and Capacity: relationships</b> • understand that capacity and volume are both measures of the size of a 3-D shape • understand that volume is a measure of how much space is occupied by a 3-D shape • understand that capacity is a measure of how much a 3-D shape can hold • explore the relationship between the cubic units of volume and capacity ( $1 \text{ cm}^3 = 1 \text{ mL}$ , $1 \text{ dm}^3 = 1 \text{ L}$ , $1 \text{ m}^3 = 1 \text{ kL}$ )	1.25 h	None	Q1, 3, 6
<b>Chapter 3 Time and Mass</b>				
<b>4.3.1</b> The 24-hour Clock System <b>SB p. 122</b> <b>TG p. 168</b>	<b>6-D6 Time: solve problems</b> • solve problems involving time • read and record time using the 24-hour clock • change time in 24-hour time to 12-hour time and vice versa	1 h	None	Q2, 3, 4
<b>4.3.2</b> The Tonne <b>SB p. 124</b> <b>TG p. 170</b>	<b>6-D7 Mass: tonnes</b> • understand that the tonne is a measure of mass and is equivalent to 1000 kg • solve problems involving tonnes	1 h	None	Q2, 5, 6
UNIT 4 Revision <b>SB p. 126</b> <b>TG p. 172</b>	Review the concepts and skills in the unit	2 h	• Rulers • Square Dot Grid Paper (BLM)	All questions
UNIT 4 Assessment Interview <b>TG p. 173</b>	Assess concepts and skills in the unit	20 to 30 min	• Geoboard or Square Dot Grid Paper (BLM) • Two paper parallelograms • Scissors • Linking cubes • Small container of water • Measuring cup • Small object like a pebble	All questions
UNIT 4 Test <b>TG p. 174</b>	Assess the concepts and skills in the unit	1 h	• Square Dot Grid Paper (BLM) (optional)	All questions
UNIT 4 Performance Task <b>TG p. 176</b>	Assess concepts and skills in the unit	1 h	None	Rubric provided
UNIT 4 Blackline Masters <b>TG p. 178</b>	BLM 1 Square Dot Grid Paper			



## Math Background

- Measurement skills are important for everyday life.
- The work in the unit extends student knowledge about area, volume, time, and mass. In particular, students explore several measurement formulas that they will use regularly in their everyday lives.
- As students proceed through this unit they will use a variety of mathematical processes, including problem solving, communication, reasoning, representation, visualization, and making connections.

For example:

- Students use problem solving in **question 5** in **lesson 4.1.1**, where they create shapes with a particular area relationship, in **question 6** in **lesson 4.1.2**, where they calculate a missing dimension in a triangle using known dimensions, in **question 7** in **lesson 4.2.1**, where they calculate the volume of a complex shape, in **question 8** in **lesson 4.2.2**, where they calculate the volume of a shape after folding it out of paper, and in **question 4** in **lesson 4.3.1**, where they calculate elapsed time.
- Students use communication in **question 6** in **lesson 4.1.1**, where they explain how to calculate an area, in **question 10** in **lesson 4.2.1**, where they relate different metric volume units, in **question 9** in **lesson 4.2.2**, where they explain when it might be useful to use displacement to calculate volume, in **question 5** in **lesson 4.3.1**, where they explain why certain digital times are not possible, and in **question 7** in **lesson 4.3.2**, where they speculate about possible units.
- Students use reasoning in **question 7** in **lesson 4.1.2**, where they explain the area relationship among different triangles, in **lesson 4.2.1**, where they reason about how a prism is constructed in order to explain the volume formula, and in **question 3** in **lesson 4.3.2**, where they describe the mass of an object that is slightly lighter than another.
- Students consider representation in **lesson 4.1.1**, where they learn that the height of a parallelogram can be measured in many locations, in **question 2** in **lesson 4.1.2**, where they use a grid to make it easy to see why different triangles have the same area, and in **lesson 4.3.1**, where they use a number line as a tool to measure how much time has passed.

- Students use visualization in **lesson 4.1.1**, where they see why the formula for the area of a parallelogram is what it is, in **question 3** in **lesson 4.1.1**, where they find dimensions of parallelograms with a given area, in the **Connections** feature where they see how the area of a parallelogram changes as the height changes, in **lesson 4.1.2**, where they relate the area of a triangle to the area of a parallelogram, and in **question 6** in **lesson 4.2.1**, where they visualize a prism inside a box.
- Students make connections in **question 4** in **lesson 4.1.2**, where they relate the areas of a parallelogram and a triangle, in **lesson 4.1.3**, where they relate areas for shapes with different but related dimensions, and where they relate different area units, in **question 1** in **lesson 4.2.2**, where they relate millilitres to cubic centimetres to solve a problem, and in **lesson 4.3.1**, where they relate 24-hour clock times to 12-hour clock times.

## Rationale for Teaching Approach

- This unit is divided into three chapters.  
**Chapter 1** focuses on area.  
**Chapter 2** focuses on volume.  
**Chapter 3** explores time and mass concepts.
- The **Explore** lesson helps students understand and interpret the meaning of area formulas by showing how changes in linear dimensions (base and height) affect changes in area.
- The **Connections** feature allows students to see why it is the height of the parallelogram, and not the side length, that affects its area.
- The **Game** provides an opportunity for students to practice calculating the areas of triangles and parallelograms.
- Throughout the unit, the focus is on developing meaning and not just on learning rules. It is important for students to explore many strategies for calculating area, volume, and elapsed time.

## Getting Started

Curriculum Outcomes	Outcome relevance
<b>3</b> Minutes: reading clocks <b>5</b> Volume and Capacity: solve simple problems <b>5</b> Perimeter and Area: rectangles and squares <b>5</b> SI Units: reinforce relationships among various SI units	Reviewing the formula for the area of rectangles, the concept of volume, metric unit relationships, and capacity and time units will help prepare students for the work in this unit.

Pacing	Materials	Prerequisites
1 h	<ul style="list-style-type: none"> <li>Rulers (optional)</li> </ul>	<ul style="list-style-type: none"> <li>calculating the area of a rectangle</li> <li>multiplying and dividing whole numbers</li> <li>familiarity with the terms <i>perimeter</i>, <i>area</i>, and <i>volume</i></li> <li>relationship between mm, cm, m, and km and between L and mL</li> <li>familiarity with mL, L, cm<sup>3</sup>, and m<sup>3</sup></li> <li>setting the hands of a clock to a given time</li> <li>calculating elapsed time (time between two events)</li> </ul>

### Main Points to be Raised

#### Use What You Know

- To calculate the area of a rectangle, you can multiply its length by its width.
- To calculate the area of parts of a shape, you can subtract the area of other parts from the area of the whole.

#### Skills You Will Need

- The perimeter of a shape is the total distance around the shape.
- The area of a rectangle is the product of the length and width.
- The volume of a shape tells how many cubes it takes to build the shape.
- 1000 mL = 1 L; 100 cm = 1 m; 1000 mm = 1 m; 1000 m = 1 km.
- A fingertip has a volume of about 1 cm<sup>3</sup>; a box that would hold a television might be 1 m<sup>3</sup>.
- There are 60 minutes in an hour. When minute hand on a clock moves one number, 5 min have passed; the hour hand on the clock moves along with the minute hand, but at  $\frac{1}{12}$  the speed.

### Use What You Know — Introducing the Unit

- Before assigning the activity, you might draw a rectangle on the board. Indicate its length and width. Ask students if they recall what the area of a rectangle is and how it is calculated.

- Students can then work in pairs to complete the activity. Note that because students are asked to estimate, they need not use their rulers, but they may do so if they wish.

While you observe students at work, you might ask questions such as the following:

- How did you estimate the length and width?* (I used my finger. I know it is about 1 cm wide, so the grey eyes are about 1 cm<sup>2</sup>.)
- How did you estimate the area of the mouth?* (It looked like it was half as wide as an eye, but 4 times as long, so I estimated 2 cm<sup>2</sup>.)
- Why did you subtract to get the area of the white region?* (I first estimated the area of the whole face and then I took away the grey areas.)
- How did you decide how big to make the rectangle you drew?* (I had estimated the white area as about 28 cm<sup>2</sup>, so I thought about two numbers that would multiply to be 28.)

## Skills You Will Need

- To ensure students have the required skills for this unit, assign all these questions.
- You may wish first to review the relationship between centimetres and metres, millimetres and metres, metres and kilometres, and millilitres and litres, as well as the meaning of the terms *perimeter* and *volume*.
- Students can work individually.

## Answers

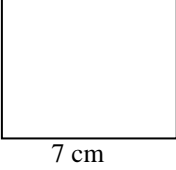
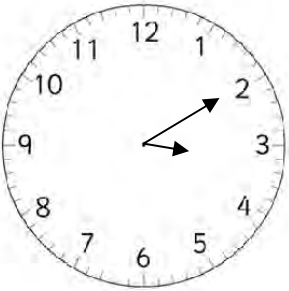
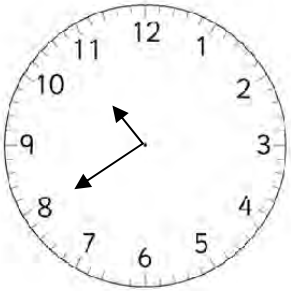
<p><b>A.</b> About <math>4 \text{ cm}^2</math></p> <p><b>B.</b> About <math>28 \text{ cm}^2</math></p>	<p><b>C. Sample responses:</b></p> <p><b>i)</b></p> <div style="text-align: center;">  </div> <p><b>ii)</b> The area of a rectangle is length <math>\times</math> width. <math>7 \times 4 = 28</math>.</p>
<p><b>1. a)</b> Perimeter = 18 cm; Area = <math>18 \text{ cm}^2</math>  <b>b)</b> Perimeter = 140 cm; Area = <math>1125 \text{ cm}^2</math></p> <p><b>2. a)</b> 100                      <b>b)</b> 1000  <b>c)</b> 10                            <b>d)</b> 1000</p> <p><b>3. Sample responses (assuming no hidden cubes):</b>  <b>a)</b> 8 cubic units            <b>b)</b> 14 cubic units</p>	<p><b>4. Sample response:</b>  <math>l = 2, w = 2, h = 9</math> or <math>l = 9, w = 4, h = 1</math>          [The three numbers must multiply to 36.]</p> <p><b>5.</b> 325 mL, 0.45 L, 2.1 L, 2300 mL</p> <p><b>6. Sample responses:</b>  <b>a)</b> A drinking glass            <b>b)</b> A pencil  <b>c)</b> A large truck                <b>d)</b> A pail</p>
<p><b>7. a)</b></p> <div style="text-align: center;">  </div> <p><b>b)</b></p> <div style="text-align: center;">  </div> <p><b>8. a)</b> 7 h and 40 min            <b>b)</b> 1 h and 49 min            <b>c)</b> 7 h and 38 min</p>	

## Supporting Students

### Struggling students

- Some students may need some re-teaching of one of these topics: metric prefix relationships, perimeter, area of a rectangle, the relative sizes of  $1 \text{ cm}^3$ ,  $1 \text{ m}^3$ , and 1 L, setting the hands of the clock, and measuring elapsed time (the amount of time between two events). Priority should be given to work with areas because that comes first in the unit.

### Enrichment

- Students may create other questions like **question 8** for classmates to solve using other times or they might like to make designs like the one in **Use What You Know** with grey and white areas, but where the white area is given.

For example, they could create a design in a rectangle where the white area must measure  $16 \text{ cm}^2$ .

# Chapter 1 Area

## 4.1.1 Area of a Parallelogram

Curriculum Outcomes	Outcome relevance
<p><b>6-D1 Area: calculate to solve problems</b></p> <ul style="list-style-type: none"> <li>• calculate area in <math>\text{cm}^2</math>, <math>\text{m}^2</math>, <math>\text{km}^2</math></li> <li>• choose appropriate units for situations</li> </ul> <p><b>6-D2 Parallelograms: relate bases, heights, and areas</b></p> <ul style="list-style-type: none"> <li>• understand that the area of a parallelogram is the same as the area of a rectangle with the same base and height</li> <li>• determine the base or height, given the area and the other dimension</li> <li>• understand that a variety of parallelograms can have the same area</li> </ul>	<p>Many shapes in our everyday lives are parallelograms. It is important for students to understand how to calculate the areas of such shapes. If students do not understand the formula for the area of a parallelogram, the formula for the area of a triangle will not make sense to them. Triangles are very important in our everyday lives.</p>

Pacing	Materials	Prerequisites
1 h	<ul style="list-style-type: none"> <li>• Paper parallelogram</li> <li>• Scissors</li> </ul>	<ul style="list-style-type: none"> <li>• formula for area of a rectangle</li> <li>• familiarity with the term <i>rhombus</i></li> </ul>

### Main Points to be Raised

- You can cut and rearrange the pieces of a parallelogram to create a rectangle. The formula for the area of the rectangle also tells the area of the parallelogram. The rectangle has the same height (previously called width) and the same base (previously called length) as the parallelogram.
- The height of a parallelogram is measured from one side to an opposite side along a line perpendicular to both sides.
- There is more than one way to rearrange a parallelogram shape into a rectangle shape with the same base and the same height.
- The formula for the area of a parallelogram is  $A = b \times h$ , where  $b$  is the base and  $h$  is the height.

### Try This — Introducing the Lesson

- A.** Allow students to try this alone or with a partner. While you observe students at work, you might ask questions such as the following:
- *Why do you think the area is less than  $8 \text{ cm} \times 8 \text{ cm}$ ?* (I imagined an 8 cm-by-8 cm square around the rhombus. The rhombus fit inside with lots of extra space.)
  - *Why do you think it might be less than  $8 \text{ cm} \times 6 \text{ cm}$ ?* (I imagined a rectangle as wide as the 6 cm diagonal and as tall as the 8 cm diagonal. The rhombus did not fill it.)
  - *How did you estimate?* (I used the  $8 \text{ cm} \times 6 \text{ cm}$  rectangle I drew around the rhombus and figured out what fraction of that area was inside the rhombus.)

### The Exposition — Presenting the Main Ideas

- Hold up a paper parallelogram. Colour the base a dark colour so students can see it clearly. Ask students to suggest how to cut up the parallelogram so you can reform it into a rectangle. Once they realize what to do, cut the parallelogram to form the rectangle. Then ask how they would calculate the area of the rectangle.
- Ask why the parallelogram had to have the same area as the rectangle. You may wish to put the pieces back in their original positions to clarify that the same pieces are being used and so the area could not change.
- Point out how the height of the rectangle is the height of the parallelogram and the base of the rectangle is the base of the parallelogram. Point out how one part of the base has been moved but that it was just rearranged, so the length did not change.
- Emphasize that the height of a parallelogram is not a side length unless the parallelogram is a rectangle.
- Record the formula for the area of a parallelogram on the board. Suggest that students write it in their notebooks.
- Have students read through the exposition on **pages 101 and 102** of the student text to confirm their understanding.

## Revisiting the Try This

**B.** These questions provide an opportunity for students to recognize why a non-square rhombus with a given side length has less area than a square with the same side length.

### Using the Examples

- Ask pairs of students to read through both examples. Ask each pair to state one thing they learned in each example. Have students share their responses.
- Work through **example 3** with the students. Show the process on the board to support what is written in the text.

### Practising and Applying

#### Teaching points and tips

**Q 1 c):** Make sure students notice that the measurements are given in different units.

**Q 2:** Although the height and base are fixed, the angles for the parallelogram are not.

**Q 3:** Students might consider factors pairs for 18, such as  $18 \times 1$  or  $9 \times 2$  or  $6 \times 3$ , but they can also use decimal or fractional values, such as  $1.8 \times 10$ .

**Q 4:** This question is designed to emphasize that the area of a parallelogram can always be computed in more than one way by using a different combination of base and height.

**Q 5:** Students can choose any area they wish for the leaves (or petals), as long as the petals are half the area of the leaves.

**Q 6:** Students must realize that it is the height, not the side length that matters when calculating the area of the parallelogram. Since the height is not given, a ruler is required.

**Q 7:** This question reinforces what students considered in **question 2**.

#### Common errors

- Some students have difficulty accepting that the base of a parallelogram does not have to be at the bottom. This may create difficulties when parallelograms are not oriented in a traditional way. Emphasize how they can rotate the shapes mentally and the area does not change.

#### Suggested assessment questions from Practising and Applying

<b>Question 1</b>	to see if students can calculate the area of a parallelogram given the base and height
<b>Question 3</b>	to see if students can create parallelograms with a particular area
<b>Question 4</b>	to see if students recognize that they can use any side of a parallelogram as a base as long as they use the appropriate height to match it

### Answers

**A. Sample response:** About  $24 \text{ cm}^2$

I drew a 6 cm-by-8 cm rectangle around the rhombus. The rhombus looked like it was about half the area of the rectangle. The area of the rectangle is  $6 \times 8 = 48 \text{ cm}^2$ , so the rhombus is about  $24 \text{ cm}^2$ .

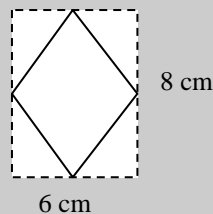

**B. Sample responses:**

**i)** The length of the base and the height.

**ii)** If I turn the rhombus on its side, I can see that the height is shorter than the 5 cm slanted side.

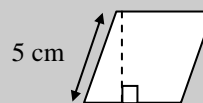

**iii)**  $A = 5 \times h$  and  $h$  is less than 5, so  $A$  is less than  $5 \times 5 = 25 \text{ cm}^2$ .

**iv)** I estimated  $24 \text{ cm}^2$  and 24 is less than 25, so my estimate was reasonable.

## Answers [Continued]

1. a)  $6 \text{ cm}^2$     b)  $1000 \text{ cm}^2$     c)  $3000 \text{ cm}^2$

2. a) 8 cm

b) *Sample response:*

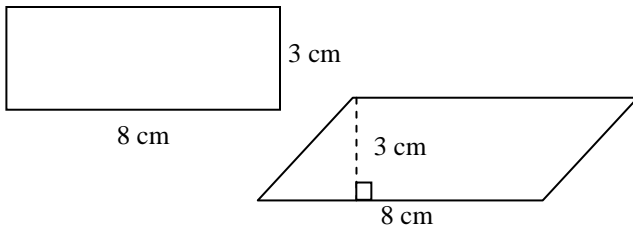

3. *Sample response:*

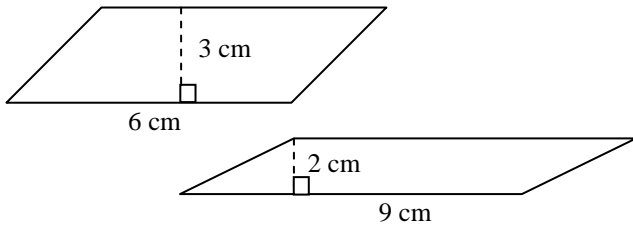

4. a)

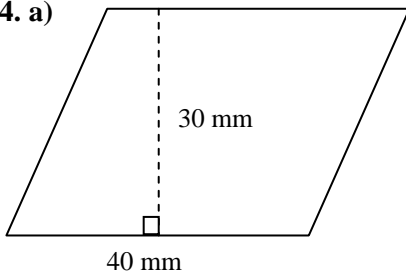

b)  $1200 \text{ mm}^2$

c) Base is 33 mm, height is 37 mm.

d)  $1221 \text{ mm}^2$

e) *Sample response:*

They are almost the same; [they should be exactly the same since they are both the same area but they are a bit different because I didn't measure accurately each time]

5. *Sample responses:*

a)

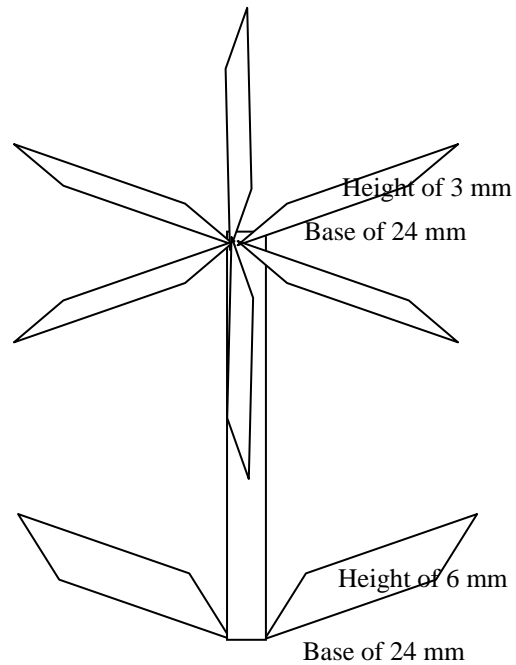

[b] I first drew two congruent parallelograms for the leaves. They had a base of 24 mm and a height of 6 mm. Then, for the six petals, I used the same base, 24 mm, but half the height, 3 mm, so the petal area was half the leaf area.]

[6. To use the area formula, you need the base and the height. The height is not labelled on the diagram, so you would need to measure it.]

[7. *Sample response:*

You can use the same base and height but make the slanted sides longer and longer (so the parallelogram is more and more slanted) so the area stays the same but the parallelogram looks different.]

## Supporting Students

### *Struggling students*

- Some students will need help in applying the area formula to calculate the height or base. You might suggest that they write open sentences.

For example, for **question 2**, they might write  $24 = 3 \times \blacksquare$ .

- Other students will struggle with **question 4**. You may need to model for them what they are actually to measure and then let them complete the measurements.

### *Enrichment*

- Students can create designs like the flower in **question 5** to match various criteria they create.

For example, they might draw a flower where the petals are  $\frac{2}{3}$  the size of the leaves. Or, they could use a completely different type of design.

## CONNECTIONS: Changing a Parallelogram

- This connection is designed to help students focus on the important role the height plays in determining the area of a parallelogram. They will see that a very short height results in a very small area. They will also see that parallelograms with the same perimeter can have different areas.
- Construct the parallelogram shown using cardboard strips that are fastened together. Make sure the strips are not too wide. Make the connections loose enough that the strips can move. If you do not have string, you can measure using paper clips or other small, uniformly-sized objects. You may ask each pair of students create their own shapes, or you can model this from the front of the room and record the measurements on the board.

### Answers

- 1. a)** Base = 15 cm; height = 8 cm  
**b)** Perimeter = 46 cm; Area =  $120 \text{ cm}^2$

**2. Sample responses:**

- a)** Base = 15 cm; height = 6 cm  
**b)** Perimeter = 46 cm, Area =  $90 \text{ cm}^2$

**3. Sample responses:**

- a)** Base = 15 cm; height = 5 cm  
**b)** Perimeter = 46 cm, Area =  $75 \text{ cm}^2$

- 4. a)** Base and perimeter  
**b)** Height and area  
**c)** The rectangle; the really slanted parallelogram

**5.** It would become smaller and smaller; [even though the base stays the same, the height would get shorter and shorter]

## 4.1.2 Area of a Triangle

Curriculum Outcomes	Outcome relevance
<p><b>6-D1 Area: calculate to solve problems</b></p> <ul style="list-style-type: none"> <li>• calculate area in <math>\text{cm}^2</math>, <math>\text{m}^2</math>, <math>\text{km}^2</math></li> </ul> <p><b>6-D3 Area of a Triangle: relate to area of a parallelogram</b></p> <ul style="list-style-type: none"> <li>• understand that any triangle is one half of a parallelogram</li> <li>• understand that the area of a triangle is half the area of the parallelogram with the same base and height</li> <li>• understand that the areas of different triangles are equal if their bases and heights are equal</li> </ul>	<p>We frequently encounter triangles in our environment, and we often have to measure them. It is important for students to understand how to calculate their areas.</p>

Pacing	Materials	Prerequisites
1 h	<ul style="list-style-type: none"> <li>• Square Dot Grid Paper (BLM)</li> <li>• Two congruent paper triangles</li> </ul>	<ul style="list-style-type: none"> <li>• area formula for a parallelogram</li> </ul>

### Main Points to be Raised

- Every triangle is half of a parallelogram with the same base and height.
- Because the area of the parallelogram is  $A = b \times h$ , the area of the triangle is  $A = b \times h \div 2$ .
- You can use any of the three sides of a triangle as the base, but you must use the corresponding height, i.e., the distance perpendicular to it from the other vertex.

### Try This — Introducing the Lesson

**A. and B.** Allow students to try this alone or with a partner. While you observe students at work, you might ask questions such as the following:

- *How did you estimate the area of the fabric?* (Instead of  $35 \times 29$ , I calculated  $33 \times 30 = 990 \text{ cm}^2$ .)
- *How did you estimate the area of one triangle?* (I figured that there are about 11 triangles in each row and there are 10 rows. That is 110 triangles to share the  $990 \text{ cm}^2$  of area. They are about  $9 \text{ cm}^2$  each.)

### The Exposition — Presenting the Main Ideas

- Hold up two identical paper triangles arranged to form a parallelogram to show that the triangle is half of a parallelogram.
- Ask students how the bases and heights of one of the triangles and the parallelogram are related (they are the same). Ask how that explains why you would calculate the area of the triangle by dividing the area of the parallelogram by two.
- Have students look at the diagrams on **page 106** in the student text. Help them see that it did not matter whether the triangle was right, acute, or obtuse – each is half of a parallelogram with the same base and height.
- Write the formula for the area of a triangle on the board. Suggest that students copy it into their notebooks.
- Have students look at the row of three triangles in the exposition on **page 107** to see how each side of the triangle is a possible base. Point out that it is critical to use the height that goes with each base. Have students notice the three different heights. Make sure they understand that the product of the base and its height will be the same, no matter which base/height combination is being used.

### Revisiting the Try This

**C.** Students can now apply the formula they learned in the exposition. They do not need to measure the base and height, but can instead calculate.



## Using the Examples

- Work through **example 1** with the students. Make sure they understand where the values for each base and height are coming from. You might copy the triangles on the board to point to each base and height as you describe it. Pay particular attention to *Triangle D*, making sure students understand that the base does not go all the way to the bottom of the segment that shows the height.
- Then have students work in pairs on **examples 2 and 3**. One of the pair should become an expert on **example 2** and the other should become an expert on **example 3**. After they each fully understands his or her example, he or she should explain it to his or her partner.

## Practising and Applying

### Teaching points and tips

**Q 1 c):** Make sure students are using the height, and not the slanted side of the triangle, to calculate the area.

**Q 2:** Some students will use triangles with the same base and height, but others will not.

**Q 4:** Students might choose particular values for the area and base and use those values to help them find a generalization.

**Q 5:** Encourage students to calculate the separate areas and add them. Make sure they realize there is one triangle (or two, depending on their perspective) and two parallelograms. To calculate the base of the triangle, they have to subtract 4 cm twice from 14 cm.

They have to add 4 cm and 4 cm to get the height of the triangle.

**Q 6:** Students need to realize they could calculate the area using the base of 4 cm and height of 3 cm, and then recognize that the area of  $6 \text{ cm}^2$  also has to be half the product of 5 and  $m$ .

**Q 7:** Students need to recognize how the bases and heights change from one triangle to the next.

**Q 8:** Students are likely to refer back to the diagram in the exposition.

**Q 9:** Some students will benefit by using number pairs to describe the bases and heights.

### Common errors

- Many students struggle with calculating the height of an obtuse triangle because the height is outside the shape. Let those students work with acute and right triangles until they are ready to deal with obtuse triangles.

### Suggested assessment questions from Practising and Applying

<b>Question 1</b>	to see if students can calculate the area of a triangle given the base and height
<b>Question 3</b>	to see if students can calculate a height given the base and area of a triangle
<b>Question 5</b>	to see if students can find the area of a complex shape involving triangles and parallelograms
<b>Question 7</b>	to see if students can reason about the relationship between the areas of triangles with related bases and heights

## Answers

<p><b>A. Sample response:</b>  <math>35 \text{ cm} \times 29 \text{ cm}</math> is about  <math>35 \text{ cm} \times 30 \text{ cm} = 1050 \text{ cm}^2</math></p>	<p><b>B. Sample response:</b> About <math>10 \text{ cm}^2</math>;          There are 10 rows of about 11 triangles, which is about 110 triangles. The whole area is <math>1050 \text{ cm}^2</math>, which is about 1100. <math>1100 \div 110 = 10</math>.</p> <p><b>C. Sample response:</b> Since the area of a triangle is <math>10 \text{ cm}^2</math>, the base and height multiply to <math>20 \text{ cm}^2</math>. The base looks a bit longer than the height, so I estimate that the base is about 5 cm and the height is about 4 cm.</p>
<p><b>1. a)</b> <math>3 \text{ cm}^2</math>  <b>b)</b> <math>8.1 \text{ cm}^2</math>  <b>c)</b> <math>7 \text{ cm}^2</math></p>	<p><b>2. Sample response:</b></p>

## Answers [Continued]

3. 0.8 cm

4. No; [Sample response:

The height of the triangle will be 2 times the height of the parallelogram. For example, the parallelogram might have a base of 4 cm and height of 2 cm. The area is  $8 \text{ cm}^2$ . If a triangle's area is  $8 = 4 \times h \div 2$ , then  $h = 4 \text{ cm}$ , which is twice as high as the parallelogram.]

5.  $56 \text{ cm}^2$

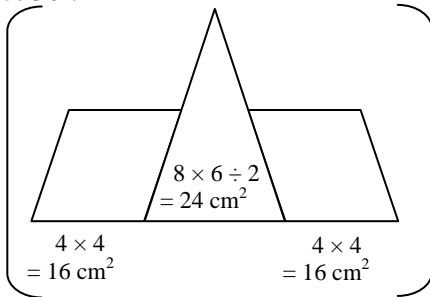

6.  $m = 2.4 \text{ cm}$ ;

$$[A = 3 \times 4 \div 2 = 6 \text{ cm}^2]$$

If the base is 5 and the height is  $m$ , then  $5 \times m \div 2 = 6$ , or  $5 \times m = 12$ .

$$m = 12 \div 5 = 2.4 \text{ cm}]$$

[7. Sample response:

The black and grey triangles have the same height, but the base of the black triangle is  $\frac{1}{2}$  the base of the grey triangle, so the area of the black triangle is  $\frac{1}{2}$  the area of the grey triangle. [Continued]

The base of the white triangle is 2 times the base of the black triangle and the height of the white triangle is 2 times the height of the black triangle. So, the area of the white triangle is 4 times the area of the black triangle, which means the area of the black triangle is  $\frac{1}{4}$  the area of the white triangle.]

[8. Sample response:

Any triangle is half the area of a parallelogram with the same base and same height. Because the area of a parallelogram is its base times its height, you have to divide the product of the base and height by 2 to get the area of the triangle.]

[9. Sample response:

You could switch what you call  $b$  and what you call  $h$ , but when you multiply them, you get the same area. For example, both these triangles have the same area.

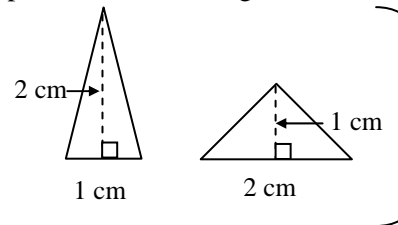

## Supporting Students

### Struggling students

- Some students have difficulty when they know the area and one dimension, but not the other dimension. They often divide the area by the base (or height), but then forget to multiply by 2 to get the other dimension. Encourage them always to check their work by using the formula.

### Enrichment

- Ask students to find all possible triangles with a given area (e.g., 12 square units) on a 6-by-6 grid.

## GAME: Grid Fill

- The purpose of the game is to help students practise calculating the areas of both triangles and parallelograms.
- To keep the game moving, encourage students to sketch rather than draw carefully.
- Students can use grid paper rather than dot paper if they wish.

## 4.1.3 EXPLORE: Relating Areas

Curriculum Outcomes	Outcome relevance
<p><b>6-C4 Area Patterns: explore</b></p> <ul style="list-style-type: none"> <li>represent symbolically changes in area based on changes in linear dimensions (e.g., parallelograms: <math>A = bh</math> so if <math>b</math> and <math>h</math> are both doubled, area is quadrupled; if <math>b</math> is doubled but <math>h</math> is halved the area remains the same)</li> </ul> <p><b>6-D4 SI Units: Relationships</b></p> <ul style="list-style-type: none"> <li>investigate the relationship between linear SI units and the relationship between corresponding SI area units</li> </ul>	<ul style="list-style-type: none"> <li>This essential exploration will help students understand the effect of multiplying a base or height by a particular factor. This will support them in later work in mathematics.</li> <li>In order to use metric units effectively, students need to see how square centimetres, square metres, and square kilometres are related.</li> </ul>

Pacing	Materials	Prerequisites
1 h	None	<ul style="list-style-type: none"> <li>formulas for the area of a parallelogram and the area of a triangle</li> </ul>

### Exploration

- Explain to students that they will be looking at how the area of a shape changes when the base and height change.
- Encourage students to work in pairs.

While you observe students at work, you might ask questions such as the following:

- Why does it make sense that the area doubled when the base doubled?* (You multiply the base by the height in the formula, so if the base is doubled, you are multiplying by an extra 2.)
- Why were the values multiplied by 4?* (The formula multiplies the base and height. If you have doubled both of them, you have multiplied by 2 twice, which is 4.)
- Why did you think that tripling the base would triple the area?* (Because  $3 \times b \times h$  is triple  $b \times h$ .)
- What would happen if you multiplied the base by 4 and divided the height by 2?* (You would multiply the area by 4 and then divide it by 2, which is like multiplying the area by 2.)
- How many square centimetres do you think are in a square metre? Why?* (If it were a parallelogram with a 1 m base and 1 m height, the area would be  $1 \text{ m}^2$ , which is  $100 \text{ cm} \times 100 \text{ cm} = 10,000 \text{ cm}^2$ .)

### Observe and Assess

As students work, notice the following:

- Do students calculate the areas correctly?
- Do students recognize the relationships shown in their chart?
- Can students generalize what they learned in the charts to predict what will happen in other situations (such as **part D**)?
- Do students realize what will happen to the areas of the triangles before they complete the charts?
- Do students predict the relationship between square metres and square centimetres, and between square metres and square kilometres?
- Can students explain the relationship between square units?

### Share and Reflect

After students have had sufficient time to work through the exploration, discuss questions such as these.

- Why did it not matter which numbers you chose for your base and height?*
- How did you predict what would happen when the base was doubled and height was tripled?*
- Suppose you multiplied the base by 5. How would you change the height to keep the same area? Would it matter whether it was a triangle or a parallelogram?*

## Answers

### Part 1

A. Sample response:

	Parallelogram A	Parallelogram B	Parallelogram C
$b$	5	6	5
$h$	4	3	2
$A$	20	18	10

B. i) Sample response:

**Double  $b$**

$b$	10	12	10
$h$	4	3	2
$A$	40	36	20

ii) The areas all double.

C. i) Sample response:

**Double  $b$  and double  $h$**

$b$	10	12	10
$h$	8	6	4
$A$	80	72	40

ii) The areas are double.

iii) The areas are 4 times as large.

**D. i) Prediction:** Triple

Check:

$$b = 5 \text{ cm and } h = 10 \text{ cm, } A = 50 \text{ cm}^2$$

$$b = 15 \text{ cm and } h = 10 \text{ cm, } A = 150 \text{ cm}^2$$

150 is triple 50.

Always true:

$$3 \times b \times h \text{ is } 3 \text{ times } b \times h.$$

**ii) Prediction:** 9 times

Check:

$$b = 5 \text{ cm and } h = 10 \text{ cm, } A = 50 \text{ cm}^2$$

$$b = 15 \text{ cm and } h = 30 \text{ cm, } A = 450 \text{ cm}^2$$

450 is 9 times 50.

Always true:

$$3 \times b \times 3 \times h = 9 \times b \times h, \text{ which is } 9 \text{ times } b \times h.$$

**iii) Prediction:** 6 times

Check:

$$b = 5 \text{ cm and } h = 10 \text{ cm, } A = 50 \text{ cm}^2$$

$$b = 10 \text{ cm and } h = 30 \text{ cm, } A = 300 \text{ cm}^2$$

300 is 6 times 50.

Always true:

$$3 \times b \times 2 \times h = 6 \times b \times h \text{ which is } 6 \text{ times } b \times h.$$

**iv) Prediction:** No change

Check:

$$b = 5 \text{ cm and } h = 10 \text{ cm, } A = 50 \text{ cm}^2$$

$$b = 10 \text{ cm and } h = 5 \text{ cm, } A = 50 \text{ cm}^2$$

$$50 = 50$$

Always true:

$$2 \times b \times h \div 2 = 2 \div 2 \times b \times h = b \times h$$

**E. i)**

**Prediction:** Triple

Check:

$$b = 5 \text{ cm and } h = 10 \text{ cm, } A = 25 \text{ cm}^2$$

$$b = 15 \text{ cm and } h = 10 \text{ cm, } A = 75 \text{ cm}^2$$

75 is 3 times 25.

Always true:

$$3 \times b \times h \div 2 \text{ is } 3 \text{ times as much as } b \times h \div 2.$$

**ii)**

**Prediction:** 9 times

Check:

$$b = 5 \text{ cm and } h = 10 \text{ cm, } A = 25 \text{ cm}^2$$

$$b = 15 \text{ cm and } h = 30 \text{ cm, } A = 225 \text{ cm}^2$$

225 is 9 times 25.

Always true:

$$3 \times b \times 3 \times h \div 2 = 9 \times b \times h \div 2 \text{ is } 9 \text{ times as much as } b \times h \div 2.$$

**iii)**

**Prediction:** 6 times

Check:

$$b = 5 \text{ cm and } h = 10 \text{ cm, } A = 25 \text{ cm}^2$$

$$b = 10 \text{ cm and } h = 30 \text{ cm, } A = 150 \text{ cm}^2$$

150 is 6 times 25.

Always true:

$$3 \times b \times 2 \times h \div 2 = 6 \times b \times h \div 2 \text{ which is } 6 \text{ times } b \times h \div 2.$$

**iv)**

**Prediction:** No change

Check:

$$b = 5 \text{ cm and } h = 10 \text{ cm, } A = 25 \text{ cm}^2$$

$$b = 10 \text{ cm and } h = 5 \text{ cm, } A = 25 \text{ cm}^2$$

$$25 = 25$$

Always true:

$$2 \times b \times h \div 2 \div 2 = 2 \div 2 \times b \times h \div 2 = b \times h \div 2$$

**Part 2**

**F. i)** *Sample response:* 1 m by 1 m  
**ii)** *Sample response:* 100 cm by 100 cm  
**iii)** 10,000 cm<sup>2</sup>  
**iv)** *Sample response:*  
I am multiplying 100 by 100, not 100 by 1.

**G. i)** *Sample response:*  
2 m base by 1 m height  
**ii)** *Sample response:*  
200 cm base by 100 cm height  
**iii)** 10,000 cm<sup>2</sup>

**H. i)** *Sample response:*  
1 km base by 1 km height  
**ii)** 1000 m base by 1000 m height  
**iii)** 1,000,000 m<sup>2</sup>  
**iv)** *Sample response:*  
I am multiplying 1000 by 1000, not 1000 by 1.

**I. i)** *Sample response:*  
2 km base by 1 km height  
**iii)** 2000 m base and 1000 m height  
**iv)** 1,000,000 m<sup>2</sup>

**Supporting Students***Struggling students*

- Some students will be able to describe what happens but will have more difficulty explaining why. It is not critical that they use letters to explain; they can just use examples at this point.
- Encourage struggling students to use simple values for  $b$  and  $h$  to make the calculations easy to do.

## Chapter 2 Volume

### 4.2.1 Volume of a Rectangular Prism

Curriculum Outcomes	Outcome relevance
<p><b>6-C3 Volume Patterns: explore</b></p> <ul style="list-style-type: none"> <li>explore how a change in one dimension of affects the volume of a rectangular prism and relate this to the volume formula, <math>V = l \times w \times h</math></li> </ul> <p><b>6-D4 SI Units: Relationships</b></p> <ul style="list-style-type: none"> <li>investigate the relationship between linear SI units and the relationship between corresponding SI volume units</li> </ul>	<ul style="list-style-type: none"> <li>The rectangular prism is one of the most basic 3-D shapes. Many real-world objects are rectangular prisms. The ability to calculate their volumes is a valuable everyday skill.</li> <li>Recognizing the relationship between different volume units allows students to choose the best unit to work with in a particular situation.</li> </ul>

Pacing	Materials	Prerequisites
1 h	<ul style="list-style-type: none"> <li>Linking cubes</li> </ul>	<ul style="list-style-type: none"> <li>factoring whole numbers</li> <li>multiplying whole numbers</li> <li>formula for the area of a rectangle</li> </ul>

#### Main Points to be Raised

- The volume of a shape tells how much space the shape occupies. It is often measured in cube equivalents.
- To calculate the volume of a rectangular prism, you can use the formula  $V = l \times w \times h$ , where  $l$  is the length of the base,  $w$  is the width of the base, and  $h$  is the height of the prism.
- You can also calculate the volume of a rectangular prism using the formula  $V = A \times h$ , where  $A$  is the area of the base and  $h$  is the height of the prism.
- Doubling one dimension of a rectangular prism doubles the volume.
- When you calculate volume, make sure all linear units are the same.
- $1 \text{ cm}^3 = 1000 \text{ mm}^3$  and  $1 \text{ m}^3 = 1,000,000 \text{ cm}^3$ .

#### Try This — Introducing the Lesson

A. Allow students to try this alone or with a partner. While you observe students at work, you might ask questions such as the following:

- How did you use the height of the car to estimate the height of the building?* (I estimated the building is 6 m tall because the car is less than one floor height and there are 3 floor heights. I multiplied  $3 \times 1.5$  and added an extra car height.)
- How could you use the building width to check your estimate for the height?* (I looked at the side of the building as if it were a rectangle. It looked almost square, so it must be about 7 m.)
- How could you use the length of the building to check your estimate for the height?* (When I look at the rectangle formed by the front of the building, I am sure the height is less than the length. I think the height is just less than  $\frac{2}{3}$  of the length, so it's about 7 m.)

#### The Exposition — Presenting the Main Ideas

- Use linking cubes to build a rectangle-based prism that measures 3 units by 2 units. Ask students to tell you the area of the top of the rectangle. Ask why the volume is 6 cubic units.
- Now put an identical layer of cubes on top of your prism. Talk about why the volume is now 12 cubic units and why, since there are two layers, you multiplied the area of the base by 2.
- Create another linking cube rectangle-based prism that measures 4 units by 3 units. Ask for its volume. Add two identical layers to the top of it and ask why the volume is now 3 times as great.

- Tell students that you can multiply the area of the base (which is length  $\times$  width) by the height to get the volume of a rectangular prism.
  - Ask students to open their texts to **page 113**. Have them look at the formula for volume on the page and copy it into their notebooks. Then lead them through the rest of the exposition.
  - Spend some time on the part of **page 115** where students see the importance of using the same unit for all three dimensions.
- For example, explain how if you multiply  $1 \times 25 \times 10$  for the 1 m-by-25 cm-by-10 cm prism, the number you get is not in cubic metres or cubic centimetres. You could use either  $100 \times 25 \times 10$  and write the volume in cubic centimetres, or  $1 \times 0.25 \times 0.1$  and write the volume in cubic metres.

### Revisiting the Try This

**B.** Students can now calculate the volume of the building in **part A** (without the roof) using the provided dimensions for length and width and the height they estimated in **part A**.

### Using the Examples

- Present the questions from the three examples to students. They should try each example and compare their work to the solutions in the text.
- Make sure students have a chance to ask questions for clarification.

### Practising and Applying

#### Teaching points and tips

**Q 1 c):** Students must either rename 1.2 m as 120 cm or rename 10 cm and 8 cm as 0.1 m and 0.08 m to solve the problem.

**Q 2:** Encourage students to pattern their solutions on **example 2**.

**Q 3 and 4:** Encourage students to refer to **example 3** for help with this question.

**Q 5:** Students need to find three factors for 80 where two of the factors are much less than the third factor. Encourage them to choose one of the greater factors of 80 for the length and then to calculate the width and depth.

**Q 6:** Students need to visualize that none of the dimensions of their prism can be greater than 5.

**Q 7:** Students must subtract the volume of the “hole” from the volume of the large block of wood. They must notice that the hole has dimensions  $3 \times 3 \times 5$  (not  $3 \times 3 \times 3$ ).

**Q 8:** Students could cut any of the three given dimensions in half. They should notice that the dimensions are not given in the same units.

**Q 9:** This question requires reasoning and analysis.

**Q 10:** Ask students how many cubic metres it takes to make a cubic kilometre.

**Q 11:** Some students might have difficulty explaining this. This question might best be handled in small groups or as a full class discussion.

#### Common errors

- Most students will be able to use the formula to calculate volume. However, they may not be careful to make sure all linear dimensions are in the same unit. You can show them how this could create errors by having them imagine a prism that is 1 m long, 1 cm wide, and 1 cm deep. Ask them why its volume cannot be  $1 \text{ cm}^3$ , which is what  $1 \times 1 \times 1$  is if you do not change the 1 m measurement to centimetres.

#### Suggested assessment questions from Practising and Applying

<b>Question 1</b>	to see if students can calculate the volume of a rectangular prism with given dimensions
<b>Question 2</b>	to see if students can calculate a dimension of a rectangular prism given its volume and other dimensions
<b>Question 4</b>	to see if students can create a rectangular prism with a given volume
<b>Question 7</b>	to see if students can solve a problem involving volumes of more than one object

## Answers

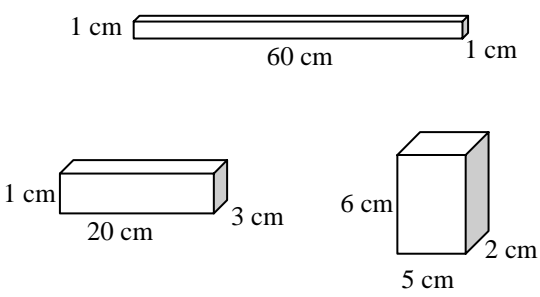
<p><b>A. Sample response:</b> 7 m; because it was a bit taller than 4 car heights tall or <math>4 \times 1.5 = 6</math> and 7 is just taller than 6</p>	<p><b>B. <math>12 \text{ m} \times 7 \text{ m} \times 7 \text{ m} = 588 \text{ m}^3</math></b></p>
<p><b>1. a) <math>180 \text{ cm}^3</math>   b) <math>1440 \text{ cm}^3</math>   c) <math>9600 \text{ cm}^3</math></b></p> <p><b>2. a) 12 cm   b) 6 cm   c) 2 cm</b></p> <p><b>3. Sample response:</b></p>  <p><b>4. Sample response:</b> 2 m by 6 m by 10 m 6 m by 4 m by 5 m 1 m by 1 m by 120 m</p> <p><b>5. Sample response:</b> 1 cm by 1 cm by 80 cm</p> <p><b>6. Sample response:</b> 4 cm by 3 cm by 3 cm</p> <p><b>7. <math>80 \text{ cm}^3</math></b></p>	<p><b>8. Sample response:</b> 25 cm by 70 cm by 30 cm</p> <p><b>9. a) 8 cm</b> <b>b) i) <math>4800 \text{ cm}^3</math>   ii) <math>9600 \text{ cm}^3</math>   iii) <math>2400 \text{ cm}^3</math></b></p> <p><b>[10. Sample response:</b> If the <math>1 \text{ km}^3</math> volume was for a cube, the cube would measure <math>1 \text{ km} \times 1 \text{ km} \times 1 \text{ km}</math>. Since <math>1 \text{ km} = 1000 \text{ m}</math>, the cube would measure <math>1000 \text{ m} \times 1000 \text{ m} \times 1000 \text{ m} = 1,000,000 \text{ m}^3</math>, which is a lot more than <math>1000 \text{ m}^3</math>.]</p> <p><b>[11. Sample response:</b> <math>l \times w \times h = V</math> Double one dimension <math>2 \times l \times w \times h = 2 \times V</math> <math>l \times 2 \times w \times h = 2 \times V</math> <math>l \times w \times 2 \times h = 2 \times V</math> Triple one dimension <math>3 \times l \times w \times h = 3 \times V</math> <math>l \times 3 \times w \times h = 3 \times V</math> <math>l \times w \times 3 \times h = 3 \times V</math> 4 times one dimension <math>4 \times l \times w \times h = 4 \times V</math> <math>l \times 4 \times w \times h = 4 \times V</math> <math>l \times w \times 4 \times h = 4 \times V</math> If you multiply one dimension, the volume changes the same way the dimension changes.]</p>

## Supporting Students

### Struggling students

- Some students may have more difficulty with situations where the dimensions are not in the same unit, like **question 1 c)**. You might choose not to assign that question right away.
- Some students will need help to find a shape with a given volume. You may wish help them with **question 4** and then let them try **question 5** on their own.
- **Questions 8 and 9** may be difficult for some students. Suggest that they work with other students on those.
- Allow students to respond to **question 11** without using the algebra. They can focus on the underlying concept, perhaps by referring to a specific example.

### Enrichment

- Students might try to discover all possible rectangular prisms with whole number centimetre side lengths with a given volume, for example,  $360 \text{ cm}^3$ . They will discover that if the volume has more factors, there are more possibilities.



## 4.2.2 Relating Volume to Capacity

Curriculum Outcomes	Outcome relevance
<b>6-D5 Volume and Capacity: relationships</b> <ul style="list-style-type: none"> <li>• understand that capacity and volume are both measures of the size of a 3-D shape</li> <li>• understand that volume is a measure of how much space is occupied by a 3-D shape</li> <li>• understand that capacity is a measure of how much a 3-D shape can hold</li> <li>• explore the relationship between the cubic units of volume and capacity (<math>1 \text{ cm}^3 = 1 \text{ mL}</math>, <math>1 \text{ dm}^3 = 1 \text{ L}</math>, <math>1 \text{ m}^3 = 1 \text{ kL}</math>)</li> </ul>	Frequently, the only convenient way to describe the capacity of a large item is to use a volume unit. Similarly, sometimes it is easiest to determine the volume of an item by using water displacement to determine its capacity measurements. Both of these situations require students to understand the relationship between volume and capacity.

Pacing	Materials	Prerequisites
1.25 h	None	<ul style="list-style-type: none"> <li>• familiarity with cubic centimetres, cubic metres, millilitres, and litres</li> <li>• describing an object with a given volume</li> </ul>

### Main Points to be Raised

- Capacity is a measure of how much something holds.
- Capacity units are often used to measure items that are filled with liquids, like water, or pourable solids, like sand or sugar or salt, because they behave like liquids.
- The main capacity units are the litre, the millilitre, and the kilolitre.
- A litre (L) is the amount of liquid that would fill a cube that is 10 cm (or 1 dm) on an edge.
- A millilitre (mL) is one thousandth as much; it is the amount of liquid that would fill a cube that is 1 cm on an edge.
- A kilolitre is 1000 L; it is the amount of liquid that would fill a cube that is 1 m on an edge.
- One way to measure volume is to figure out the amount of water that is displaced when the item is immersed in water. For each mL of water displaced, the volume is  $1 \text{ cm}^3$ .

### Try This — Introducing the Lesson

**A.** Allow students to try this alone or with a partner. They might pretend that the bucket is 30 cm wide all the way down, or they might estimate the width as 25 to 27 cm to account for the fact that the bottom is narrower.

While you observe students at work, you might ask questions such as the following:

- *How much water would a cube that is 10 cm on a side hold?* (It would hold 1 L because that is what a litre is.)
- *How many of those cubes would be the height of the bucket?* (3 cubes high)
- *How many of those cubes would be the width and depth of the bucket?* (3 cubes wide and 3 cubes deep if I use 30 cm as the estimate of the width of the circles at the top and bottom of the bucket.)
- *How does that help you estimate the number of litres?* (I use  $3 \times 3 \times 3$  and get 27, but since the bottom is not really 3 cubes wide, I might actually estimate 25 L.)

Note that estimates may vary since the width of the bucket is not constant and since students may relate the bucket to various other real-world objects.

### The Exposition — Presenting the Main Ideas

- Work through the exposition on **pages 118 and 119** of the student text with the students. Guide them through the explanations.
- Make sure that they recognize that they can substitute 1 L for  $1000 \text{ cm}^3$ , 1 mL for  $1 \text{ cm}^3$ , and 1 kL for  $1 \text{ m}^3$ .
- Make sure that students recognize the types of situations in which each capacity unit makes the most sense.
- You might talk about how a capacity measure based on the outside dimensions of a container is only an estimate, as it does not take into account the actual capacity taken up by the container itself. Outside dimensions or volume measures based on the capacity of a container are estimates for the same reason. Encourage students to preface their measurements with "about" in these instances, but do not require it or penalize them for not doing it.

## Revisiting the Try This

**B.** This question asks students to relate volume units to capacity units using the situation in **part A**.

### Using the Examples

- Present the problem from **example 1** to the students. Let them try it and then compare their responses to the solution and thinking in the text.
- Let students read through **example 2**. Use cubes to demonstrate if possible.

### Practising and Applying

#### Teaching points and tips

**Q 1:** Students must first calculate the volume and then relate it to millilitres.

**Q 2:** Students need to find three numbers that multiply to each of the given values.

For example, for 4 L, they could use  $2 \times 2 \times 1$ , but then they must remember to use dm as units.

Or, they could change 4 L to 4000 mL and use  $20 \times 20 \times 10$  and use centimetre units.

**Q 3:** Students need to change 1 L to 1000 mL to answer this question.

**Q 5:** Students might consider only the widths of the boxes, only the depths, or both.

For example, the other box could be half as wide and the same depth, half the depth and the same width, or, perhaps, twice as wide and one fourth the depth.

**Q 6:** This question requires problem solving and reasoning. Students must recognize that the base of the container is  $25 \text{ cm}^2$  and figure out the necessary height to result in a volume of either  $250 \text{ cm}^3$  or  $375 \text{ cm}^3$ .

**Q 9:** This question might be discussed as a class.

#### Common errors

- Some students will not relate the capacity and volume units properly. For example, they might think that a kL describes a cube that measures 1 km on each side. Suggest that students draw in their notebooks the dimensions of the cube that goes with each capacity measure.

#### Suggested assessment questions from Practising and Applying

<b>Question 1</b>	to see if students can relate capacity units to volume units for a rectangular prism
<b>Question 3</b>	to see if students understand how to use water displacement to calculate volume
<b>Question 6</b>	to see if students can solve a problem related to volume

### Answers

**A. Sample response:** About 25 L;

The bucket is about 3 times as high, 3 times as wide, and 3 times as deep as a litre cube. That means it would hold about 27 L. But since it is not 30 cm wide all the way down, I might actually estimate 25 L.

**B. Sample response (based on the estimate in part A):**  $25 \text{ L} = 25,000 \text{ cm}^3$  so the prism's volume would be about  $25,000 \text{ cm}^3$

**1. a)** About 850 mL

**b)** About 2205 mL

**2. Sample responses:**

First prism

**a)**

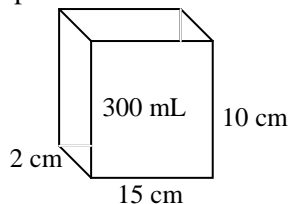

**b)**

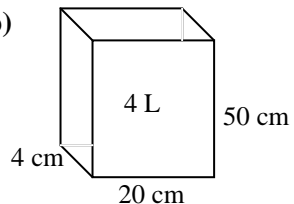

**c)**

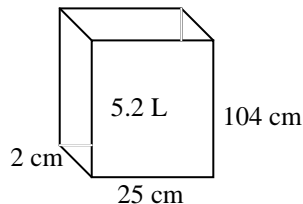

**d)**

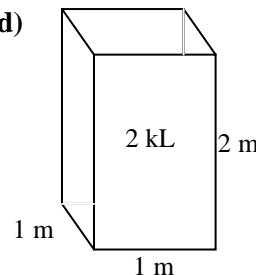

Second prism

**a)** 2 cm by 30 cm by 5 cm   **b)** 16 cm by 25 cm by 10 cm   **c)** 2 cm by 50 cm by 102 cm   **d)** 2 m by 0.5 m by 2 m

<p><b>3. a)</b> <math>177 \text{ cm}^3</math>                      <b>b)</b> <math>650 \text{ cm}^3</math></p> <p><b>4. A;</b> [A has a volume of <math>5200 \text{ cm}^3</math> and a capacity of about 5200 mL. C has a volume of <math>4704 \text{ cm}^3</math> and a capacity of about 4704 mL.]</p> <p><b>5. a)</b> The area of the base of the tall box is half the area of the other prism base. <b>b)</b> The product of the length and width of the base of the tall box is half the product of the length and width of the shorter box.</p> <p><b>6. a)</b> 10 cm; [<math>250 \text{ mL} = 250 \text{ cm}^3</math> <math>5 \text{ cm} \times 5 \text{ cm} \times \text{height (depth)} = 250 \text{ cm}^3</math> <math>25 \times \text{depth} = 250</math> Depth = 10 cm]</p>	<p><b>b)</b> 15 cm; [<math>375 \text{ mL} = 375 \text{ cm}^3</math> <math>5 \text{ cm} \times 5 \text{ cm} \times \text{height (depth)} = 375 \text{ cm}^3</math> <math>25 \times \text{depth} = 375</math> Depth = 15 cm]</p> <p><b>7.</b> 10 cm, 11 cm, and 12 cm</p> <p><b>8.</b> Each square was 3 cm by 3 cm.</p> <p><b>[9. Sample response:</b> It is difficult to find the volume of odd-shaped objects by using length, width, and height measurements, but you can measure how much the water level rises if your put it in water.]</p>
---	--

## Supporting Students

### *Struggling students*

- Struggling students may have difficulty with questions like **questions 6, 7, and 8**. You may choose not to assign those questions, you may help students by giving them a clue to get started, or you may assign students to work on these questions with a partner who is not struggling.

### *Enrichment*

- Students might create problems like those in **questions 6 and 8** for other students to solve. They could trade problems and solve each other's.

## Chapter 3 Time and Mass

### 4.3.1 The 24-hour Clock System

Curriculum Outcomes		Outcome relevance
<b>6-D6 Time: solve problems</b> <ul style="list-style-type: none"><li>• solve problems involving time</li><li>• read and record time using the 24-hour clock</li><li>• change time in 24-hour time to 12-hour time and vice versa</li></ul>		The 24-hour clock is used in a variety of everyday situations. Students need to become familiar with it.
Pacing	Materials	Prerequisites
1 h	None	<ul style="list-style-type: none"><li>• reading digital times using a 12-hour clock</li><li>• 60 min = 1 h</li></ul>

#### Main Points to be Raised

- In the 24-hour clock system, midnight is called 00:00 and time proceeds through to the next midnight, which begins one minute after 23:59. There is no reference to a.m. or p.m.
- An a.m. time is the same in both the 12-hour and 24-hour clock systems. The only difference is that in the 24-hour system, there is a zero in the tens digit for times before 10 a.m. To change a p.m. time to a 24-hour time, add 12.
- The value of the 24-hour clock system is that there is different name for each hour of the day. This eliminates confusion.  
For example, there is only one 7 o'clock.
- The disadvantage of a 24-hour clock is that most clocks and watches only use 12 numbers, so we must translate between 12-hour and 24-hour time.

#### Try This — Introducing the Lesson

**A.** Allow students to try this alone or with a partner. While you observe students at work, you might ask questions such as the following:

- *How much later did the flight leave on Wednesday than on Friday?* (1 h and 20 min)
- *How much later did it arrive?* (1 h and 25 min)

Note that the problem is designed so that it is irrelevant that Bangkok is in a different time zone than Paro.

#### The Exposition — Presenting the Main Ideas

- Ask students if they have ever read a bus schedule or seen a computer state a time using an hour beyond 12 o'clock, for example, 13:15. If they have, ask them to explain what they recall. If they have not, discuss how this is a time based on a 24-hour clock system. Explain how it differs from the 12-hour clock system they are used to.
- Show students how the day progresses from 00:00 hours at midnight, to 06:00 hours, when they might wake up, to 12:00 hours at noon, to 16:00 hours, when they might leave school, and then to 20:00 hours, when they might go to sleep. Explain that after the time reaches 23:59, it goes back to 00:00 to begin the next day.
- Present some a.m. and p.m. times. Ask students to translate them to 24-hour time. Then do the reverse, starting with 24-hour times like 14:20, 18:36, or 07:40 and have students write them as 12-hour times.
- Have students read the exposition on **page 122** of the student text. Make sure they understand how the 24-hour clock system works.

#### Revisiting the Try This

**B.** Students can use the 24-hour clock system to write the afternoon times they met in **part A**.

#### Using the Examples

- Present the problem in the example to the students. They can try it and then compare their work to the work in the student text. Point out how a number line can be a useful tool, as shown in **part b**).

## Practising and Applying

### Teaching points and tips

**Q 2:** Students need to recall that it is midnight, not noon that is 00:00 hours.

**Q 3:** Do not penalize students for writing 07:00 a.m. rather than 7 a.m. or 7:00 a.m., but point out that this is not the convention.

**Q 4:** Encourage students to use a number line as in the example to help them with this question. They should use easy jumps, for example, from 14:20 to 23:20, then from 23:20 to 00:00, and finally from 00:00 to 09:15.

**Q 5:** This question is designed to get to students to think about what times are possible with the 24-hour clock system.

### Common errors

- Some students will subtract as if the numbers were regular numbers and get the wrong answers for **question 4**. For example, they will write  $1420 - 915 = 505$  and say that it took 5 hours and 5 minutes. Encourage students to estimate to see if their calculations are reasonable.

### Suggested assessment questions from Practising and Applying

<b>Question 2</b>	to see if students can change 12-hour clock times to 24-hour clock times
<b>Question 3</b>	to see if students can change 24-hour clock times to 12-hour clock times
<b>Question 4</b>	to see if students can calculate elapsed time using the 24-hour clock system

### Answers

<p><b>A.</b> The Friday flight; <i>Sample response:</i> The Wednesday flight leaves 1 h and 20 min later in the day and arrives 1 h and 25 min later the same day, so it is 5 minutes longer.</p>	<p><b>B.</b> 15:20 and 13:55</p>
<p><b>1.</b> 15:13</p> <p><b>2.</b> a) 04:15                      b) 18:23 c) 12:00                        d) 21:34</p> <p><b>3.</b> a) 7:00 a.m.                b) 6:25 p.m. c) 10:17 p.m.                d) 11:33 a.m.</p> <p><b>4.</b> a) 10 h and 30 min b) 18 h and 55 min c) 15 h and 45 min</p>	<p><b>[5. a)</b> There are only 60 min in 1 h, so the minute number cannot be greater than 59. <b>b)</b> There are only 24 h in a day, so the hour number cannot be greater than 23.]</p> <p><b>[6. Sample response:</b></p> <ul style="list-style-type: none"> <li>If the hour is 0, change the hour to 12 and add a.m. after the time.</li> <li>If the hour is less than 12 but greater than 0, write the time in the same way but drop the 0 at the beginning, if there is a 0, and write a.m. after the time.</li> <li>If the hour is 12, write the time in the same way, and add p.m. after the time.</li> <li>If the hour is 13 or more, subtract 12 from the hour (but do not change the minutes) and then write p.m. after the time.]</li> </ul>

## Supporting Students

### Struggling students

- Some students may have difficulty with **question 4**. You may choose to use only times on the same day to start these students off.

For example, you could change **question 4 b)** to “14:20 one day to 23:15 the same day”.

### Enrichment

- Ask students to use a 24-hour clock to describe their activities on a particular day.

## 4.3.2 The Tonne

Curriculum Outcomes		Outcome relevance
<b>6-D8 Mass: tonnes</b> <ul style="list-style-type: none"> <li>understand that the tonne is a measure of mass and is equivalent to 1000 kg</li> <li>solve problems involving tonnes</li> </ul>		Students may encounter the term <i>tonne</i> when they read about large objects. They should have a sense of its size.
Pacing	Materials	Prerequisites
1 h	None	<ul style="list-style-type: none"> <li>familiarity with decimal thousandths</li> <li>multiplying and dividing mentally by 100 and 1000</li> </ul>

### Main Points to be Raised

- A tonne (1 t) is 1000 kg.
- To convert kilograms to tonnes, divide by 1000. To convert tonnes to kilograms, multiply by 1000.
- Whether grams, kilograms, or tonnes are used to describe a mass depends on the size of the object. It is better to have a number that is neither too big nor too small.

### Try This — Introducing the Lesson

**A.** Allow students to try this alone or with a partner. While you observe students at work, you might ask questions such as the following:

- Why did you estimate 370 as 400?* (It made the calculations easier to do.)
- About how many groundnuts would balance 54 kg?* (I used  $400 \times 50$  to get 20,000, the amount in 54 kg.)
- Why would the number of groundnuts that would balance the elephant be 100 times as great as the amount that would balance 54 kg?* (5400 is 100 times as much as 54.)

### The Exposition — Presenting the Main Ideas

- Ask students to recall how grams and kilograms are related. Ask why  $3 \text{ kg} = 3000 \text{ g}$  and why  $4000 \text{ g} = 4 \text{ kg}$ .
- Tell students that just like 1000 g make 1 kg, 1000 kg make 1 tonne. Tell them that this is called a metric ton. Its abbreviation is the small letter *t*. A tonne is slightly larger than another unit called a ton, which is used in some countries.
- Ask them to complete each of these:  $3000 \text{ kg} = \blacksquare \text{ t}$  and  $4 \text{ t} = \blacksquare \text{ kg}$ .

### Revisiting the Try This

**B.** Students can now use tonnes to describe the mass of the elephant in **part A**, making the numbers they are working with more reasonable in size.

### Using the Examples

- Present the question in the example by recording it on the board. Ask students to try it and then to compare their work with the solution in the student text.

### Practising and Applying

#### Teaching points and tips

**Q 1:** Students have to use everyday knowledge for this question. They should start with items they are sure of and eliminate those values from consideration for items they are less sure of.

**Q 3:** There is some flexibility in how students interpret the phrase “a bit lighter”.

**Q 5:** Ask students how they know the number will be less than 1.

**Q 6:** Students could rewrite 100 kg as 0.1 t or they could rename 300 t as 300,000 kg.

**Q 7:** This fun question gets students to focus on what the metric prefixes mean.

### Common errors

- Some students will use 100 rather than 1000 as the conversion factor between kilograms and tonnes. This is probably because they are so used to using 100 to convert between metres and centimetres. Keep reminding them that a tonne is 1000 kg, not 100 kg.

### Suggested assessment questions from Practising and Applying

<b>Question 2</b>	to see if students can compare measurements written as tonnes with measurements written as kilograms
<b>Question 5</b>	to see if students can change a kilogram measurement to a decimal tonne measurement
<b>Question 6</b>	to see if students can solve a problem involving kilograms and tonnes

### Answers

<b>A. Sample response:</b> About 2 million groundnuts; In 1 kg, there are 370, or about 400 groundnuts. In 1000 kg, there are about 400,000 groundnuts. In 5000 kg, there are 5 times as many groundnuts, or 2,000,000.	<b>B. i)</b> 5.4 t <b>ii)</b> A groundnut is very light so it would not even be close to 0.001 t.
<b>1. A.</b> 2 t <b>B.</b> 60 g <b>C.</b> 4 kg <b>D.</b> 12 kg <b>E.</b> 12 t <b>F.</b> 500 g	<b>4.</b> 38,000,000 kg
<b>2. a)</b> 350 g, 3.5 kg, 1.2 t, 1500 kg, 1.82 t <b>b)</b> 23 kg, 0.23 t, 2.03 t, 2033 kg, 2300 kg	<b>5.</b> 0.909 t
<b>3. Sample response:</b> 2299 kg	<b>6.</b> 3000 bags  [7. Kilo in the metric system means thousand. That is why 1 kg = 1000 g. Because 1 t = 1000 kg, it would make sense to say kilo-kilograms.]

### Supporting Students

#### Struggling students

- Students may have difficulty with **question 5**, where a decimal is required. Focus on why it makes sense that the answer is less than 1 and why it makes sense to use decimal thousandths (because 1000 kg = 1 t).
- For **question 6**, have students rename 300 t as 300,000 kg before they proceed.

# UNIT 4 Revision

Pacing	Materials
2 h	<ul style="list-style-type: none"> <li>• Rulers</li> <li>• Square Dot Grid Paper (BLM)</li> </ul>

Question(s)	Related Lesson(s)
1 – 4	Lesson 4.1.1
5 – 8	Lesson 4.1.2
9 and 10	Lesson 4.1.3
11 – 14	Lesson 4.2.1
15 – 18	Lesson 4.2.2
19 – 21	Lesson 4.3.1
22 and 23	Lesson 4.3.2

## Revision Tips

**Q 2:** Students may need to measure to see that the two bases are the same length.

**Q 3 b):** Students first need to consider possible combinations of numbers to multiply to 60. Then they can find which pair of numbers are 11 apart.

**Q 9 and 10:** Students might use examples to answer these questions.

**Q 11:** Students can convert all measures to metres or they might convert all to centimetres.

**Q 13:** Students need to know that  $1 \text{ m}^3 = 1,000,000 \text{ cm}^3$ .

**Q 14:** Students need to realize that the cut-out holes measure 4 cm by 4 cm by 20 cm.

## Answers

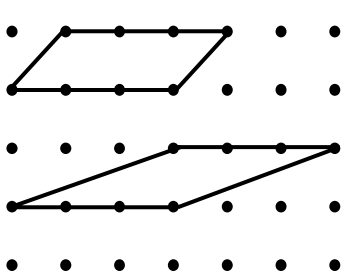
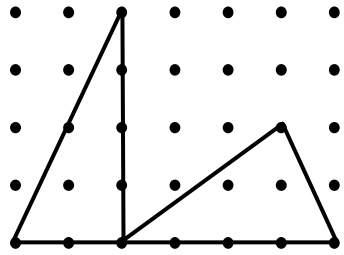
<p>1. a) <math>900 \text{ cm}^2</math>                      b) <math>480 \text{ cm}^2</math></p> <p>2. The rectangle; [The bases are the same but the height of the rectangle is greater.]</p> <p>3. a) 6 cm                                  b) 4 cm</p> <p>4. <i>Sample response:</i></p>  <p>5. a) <math>575 \text{ cm}^2</math>                      b) <math>900 \text{ cm}^2</math></p>	<p>6. <i>Sample response:</i></p>  <p>7. 24 m</p> <p>8. <math>3300 \text{ cm}^2</math> [1800 for the parallelogram + 1500 for the triangle]</p> <p>9. a) Parallelogram B has twice the area of Parallelogram A. b) Triangle A has one fourth the area of Triangle B.</p> <p>10. The parallelogram has four times the area of the triangle.</p>
--	--



<p><b>11. a)</b> <math>0.1 \text{ m}^3</math> or <math>100,000 \text{ cm}^3</math>  <b>b)</b> <math>0.6 \text{ m}^3</math> or <math>600,000 \text{ cm}^3</math></p> <p><b>12. Sample response:</b>  10 cm by 10 cm by 2 cm or  5 cm by 20 cm by 2 cm</p> <p><b>13.</b> 600 cm or 6 m</p> <p><b>14.</b> <math>11,040 \text{ cm}^3</math></p> <p><b>15.</b> about 30 L</p> <p><b>16. Sample response:</b>  About 25 cm by 10 cm by 10 cm or  25 cm by 50 cm by 2 cm</p>	<p><b>17.</b> <math>250 \text{ cm}^3</math></p> <p><b>18.</b> About 8 cm</p> <p><b>19. a)</b> 13:23                      <b>b)</b> 00:00</p> <p><b>20. a)</b> 5:49 p.m.                <b>b)</b> 6:17 a.m.  <b>c)</b> 3:18 p.m.                      <b>d)</b> 6:15 p.m.</p> <p><b>21. a)</b> 4 h and 27 min  <b>b)</b> 7 h and 45 min</p> <p><b>22. a)</b> 23,000                      <b>b)</b> 3400  <b>c)</b> 1.520</p> <p><b>23.</b> 2.5 t</p>
---	---

## UNIT 4 Assessment Interview

You may wish to interview selected students to assess their understanding of the work of this unit. Interviews are most effective when done with individual students, although pair and small group interviews are sometimes appropriate. The results can be used as formative assessment or as summative assessment data. As the students work, ask them to explain their thinking.

Have available the following:

- a geoboard or square dot grid paper (BLM)
- two paper parallelograms
- scissors
- small linking cubes
- a small container of water
- a measuring cup
- a small object like a pebble

Ask the student the following questions:

- *What is the formula for the area of a rectangle? What is the formula for the area of a parallelogram? How can you cut the parallelogram to show why the formula for the area of a parallelogram works?*
- *What is the formula for the area of a triangle? How can you use a parallelogram to show why the formula for the area of a triangle works?*
- *On the geoboard or dot paper, make a parallelogram with an area of 5 square units. How could you make another parallelogram with the same area? How could you make a triangle with the same area?*
- *Use the cubes to build a rectangular prism. What is its volume? How do you know?*
- *How will the volume of the prism change if you make it twice as high? Why?*
- *How could you figure out the volume of this pebble?*

# UNIT 4 Measurement Test

1. Calculate the area of each shape.

a)

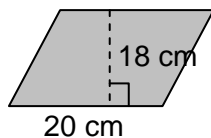

b)

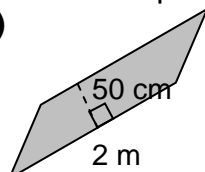

c)

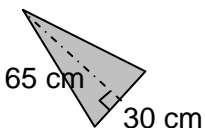

d)

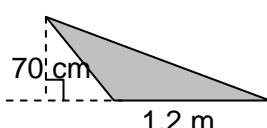

2. Use the grid below. Draw a parallelogram and a triangle, each with an area of 8 square units. The shapes may overlap.

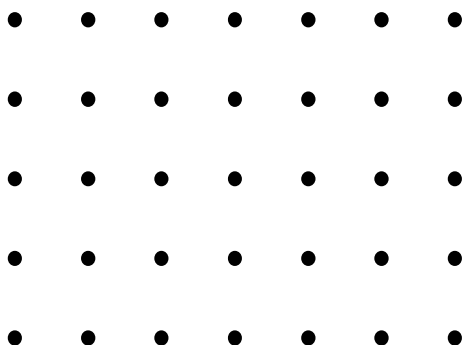

3. Sketch a shape that is made by combining two triangles and a parallelogram. The total area must be  $24 \text{ cm}^2$ . Label the dimensions of the shape.

4. Explain why the formula for the area of a triangle involves dividing by 2.

5. Triangle A has base  $b$  and height  $h$ . Triangle B has 4 times the area of Triangle A. What might be the base and height of Triangle B?

6. Calculate the volume of each prism.

a)

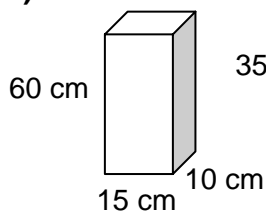

b)

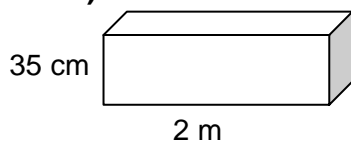

7. Find the missing value for each rectangular prism.

- a)  $Volume = 200 \text{ cm}^3$   
 $Height = 10 \text{ cm}$   
 $Area \text{ of the base} = ?$
- b)  $Volume = 300 \text{ cm}^3$   
 $Length = 10 \text{ cm}$   
 $Width = 5 \text{ cm}$   
 $Height = ?$

8. A wooden block is a rectangular prism with a volume of  $320 \text{ cm}^3$ .

- a) List a possible set of dimensions for the prism (length, width, and height). Find two other possible sets of dimensions.
- b) A 3 cm square hole is cut all the way through the block. Sketch what it might look like. Label the dimensions. Find the volume of the remaining wood.

9. A rectangular prism holds 2.1 L of water. What might be its length, width, and height?

10. Write each in 24-hour clock time.

- a) 3:20 p.m.  
 b) 8:15 a.m.  
 c) 11:22 p.m.

11. How much time is there between each pair of times?

- a) 07:22 one day and 13:15 the same day  
 b) 18:40 one day and 03:20 the next day

12. Write each mass in tonnes.

- a) 310 kg    b) 27 kg    c) 2345 kg

13. Choose either **part a) or b)** to answer.

- a) How do you convert a measurement in tonnes to kilograms? Use an example to explain.
- b) How do you convert a 12-hour p.m. clock time to a 24-hour clock time?

## UNIT 4 Test

Pacing	Materials
1 h	• Square Dot Grid Paper (BLM) (optional)

Question(s)	Related Lesson(s)
1 – 3	Lessons 4.1.1 and 4.1.2
4	Lesson 4.1.2
5	Lesson 4.1.3
6 – 8	Lesson 4.2.1
9	Lesson 4.2.2
10 and 11	Lesson 4.3.1
12	Lesson 4.3.2
13	Lessons 4.3.1 and 4.3.2

Select questions to assign according to the time available.

### Answers

1. a)  $360 \text{ cm}^2$       b)  $1 \text{ m}^2$  [or  $10,000 \text{ cm}^2$ ]  
 c)  $975 \text{ cm}^2$       d)  $0.42 \text{ m}^2$  [or  $4200 \text{ cm}^2$ ]

2. Sample response:

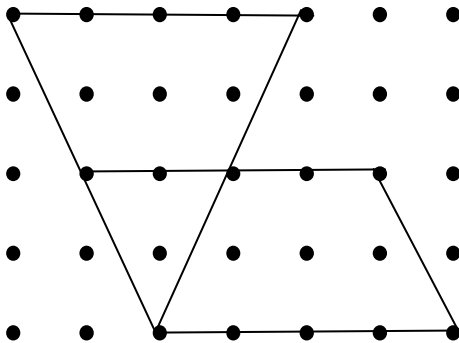

3.

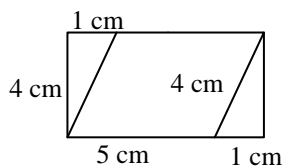

4. Sample response:

Each triangle is half of a parallelogram with the same base and height. Since the area of the parallelogram is  $\text{base} \times \text{height}$ , you have to divide by 2 to get the area of half of the parallelogram.

5. Sample response:

The base is  $4b$  and the height is  $h$ . [Any combination where the product of the base and height is  $4bh$  will work.]

6. a)  $9000 \text{ cm}^3$       b)  $140,000 \text{ cm}^3$  [or  $0.14 \text{ m}^3$ ]

7. a)  $20 \text{ cm}^2$       b) 6 cm

8. Sample responses:

- a)  $h = 4 \text{ cm}$ ;  $w = 8 \text{ cm}$ ;  $l = 10 \text{ cm}$  or  
 $h = 8 \text{ cm}$ ;  $w = 8 \text{ cm}$ ;  $l = 5 \text{ cm}$  or  
 $h = 16 \text{ cm}$ ;  $w = 4 \text{ cm}$ ;  $l = 5 \text{ cm}$

b) Using the 4 cm by 8 cm by 10 cm prism:

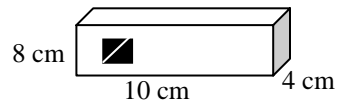

$$248 \text{ cm}^3 [320 - 3 \times 3 \times 8 \text{ cm}^3]$$

9. Sample response:

About 10 cm by 3 cm by 70 cm. [The three numbers should multiply to 2100 if they are in centimetres.]

10. a) 15:20      b) 08:15      c) 23:22

11. a) 5 h and 53 min      b) 8 h and 40 min

12. a) 0.310 t      b) 0.027 t      c) 2.345 t

13. Sample responses:

a) You multiply the number of tonnes by 1000. For example, 3 t would be 3000 kg.

or

b) You add 12 to the hour and you do not change the minutes.

## UNIT 4 Performance Task — Building a Rectangular Prism

A. Record the time when you start this task as a 24-hour clock time.

B. i) Calculate the area of the parallelogram.

ii) Calculate the area of the triangle.

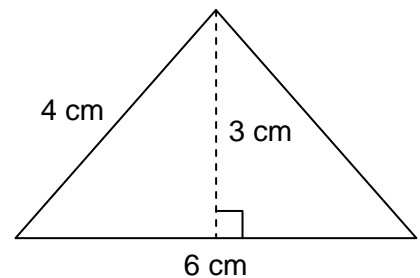
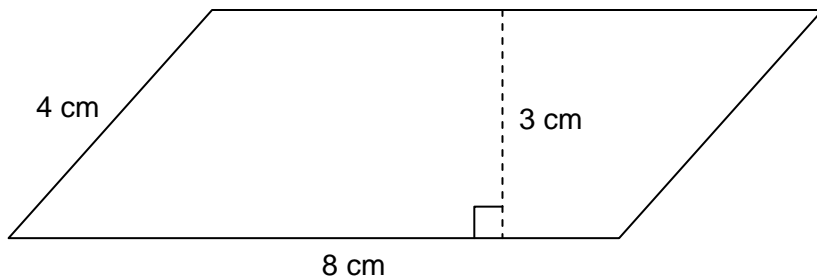

C. i) Trace the two shapes and cut them out. Cut the triangle in half along the dashed line. Put the three pieces together to make a rectangle.

ii) Sketch a diagram of the rectangle that shows the three pieces.

Label the rectangle with its dimensions (use the dimensions shown on the diagrams above to figure out the dimensions of the rectangle).

D. i) Imagine that the rectangle in **part C** is the base of a rectangular prism with a height of 12 cm. Calculate its volume.

ii) A different rectangular prism has the same volume as the prism in **part D i)**. Its dimensions are whole numbers. What could be its dimensions?

E. If the prism in **part D** were a container, about how many litres of water would it hold?

F. i) Imagine that the rectangle in **part C** is the base of a rectangular prism with a height of 6 cm. Calculate its volume. How could you have predicted this volume?

ii) A different rectangular prism has the same volume as the prism in **part F i)**. Its dimensions are whole numbers. What could be its dimensions?

iii) If the prism in **part F ii)** were a container, about how many litres of water would it hold?

G. i) Record the time when you finish this task as a 24-hour clock time.

ii) How long did it take you to complete the task?

## UNIT 4 Performance Task

Curriculum Outcomes Assessed	Pacing	Materials
<b>6-C3</b> Volume Patterns: explore <b>6-C4</b> Area Patterns: explore <b>6-D2</b> Parallelograms: relate bases, heights, and areas <b>6-D3</b> Area of a Triangle: relate to area of a parallelogram <b>6-D5</b> Volume and Capacity: relationships <b>6-D6</b> Time: solve problems	1 h	None

### How to Use This Performance Task

- You might use this task as a rich problem to assess student understanding of a number of outcomes in this unit. It could replace or supplement the unit test. It could also be used as enrichment material for some students.
- You can assess performance on the task using the rubric on the next page.

### Sample Solution

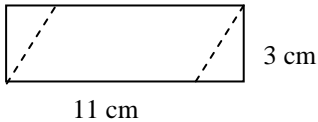
<p><b>A.</b> 14:30</p> <p><b>B. i)</b> <math>24 \text{ cm}^2</math> <b>ii)</b> <math>9 \text{ cm}^2</math></p> <p><b>C.</b> </p> <p><b>D. i)</b> <math>396 \text{ cm}^3</math> <b>ii)</b> 11 cm by 9 cm by 4 cm</p>	<p><b>E.</b> 396 mL, or about 0.4 L.</p> <p><b>F. i)</b> <math>198 \text{ cm}^3</math>; If one dimension is halved, the volume is halved. <b>ii)</b> 11 cm by 9 cm by 2 cm <b>iii)</b> About 198 mL, or about 0.2 L</p> <p><b>G. i)</b> 15:18 <b>ii)</b> 48 min [from 14:30 to 15:18]</p>
--	---

### UNIT 4 Performance Task Assessment Rubric

<i>The student</i>	Level 4	Level 3	Level 2	Level 1
<b>Calculates areas of parallelograms and triangles</b>	Efficiently and accurately calculates areas of parallelograms and triangles; easily predicts the dimensions of a shape with a related base area	Accurately calculates areas of parallelograms and triangles using formulas	Calculates the areas of some parallelograms and triangles using formulas	Has difficulty applying the formulas for calculating the areas of parallelograms and triangles
<b>Calculates volumes, related volumes and capacities, and elapsed time</b>	Efficiently and accurately calculates volumes of rectangular prisms; insightfully describes prisms with a given volume; correctly relates volume to capacity and measures elapsed time	Accurately calculates volumes of rectangular prisms, correctly describes prisms with a given volume; correctly relates volume to capacity and measures elapsed time	Correctly calculates several of: the volumes of rectangular prisms, capacity values to match volumes, and elapsed time	Has difficulty calculating volumes of rectangular prisms, capacity values to match volumes, and elapsed time

# UNIT 4 Blackline Masters

## BLM 1 Square Dot Grid Paper

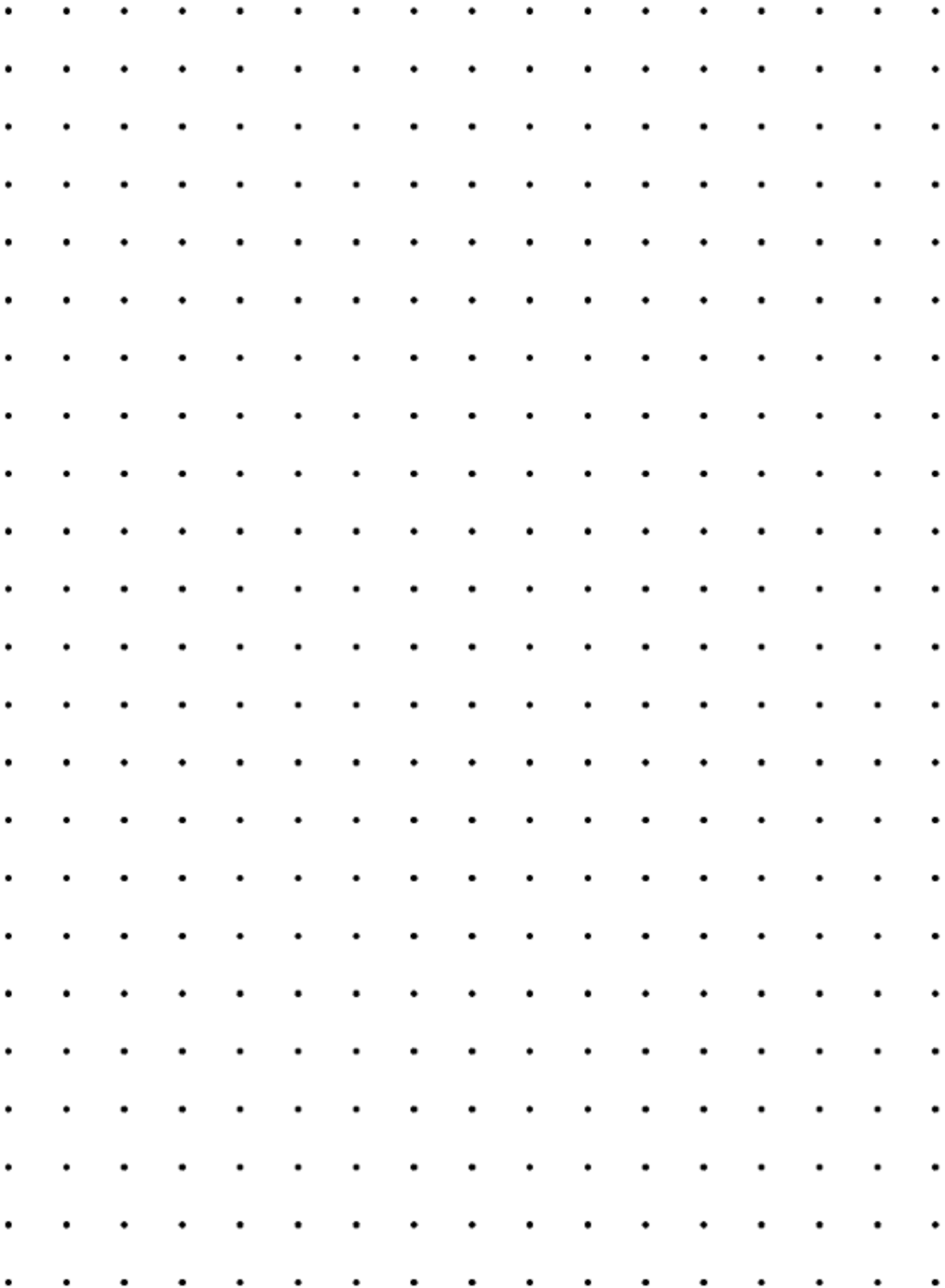

# UNIT 5 RATIO, RATE, AND PERCENT

## UNIT 5 PLANNING CHART

	Outcomes or Purpose	Suggested Pacing	Materials	Suggested Assessment
Getting Started SB p. 129 TG p. 182	Review prerequisite concepts, skills, and terminology and pre-assessment	1 h	• Getting Started Squares (BLM) (optional)	All questions
<b>Chapter 1 Ratio and Rate</b>				
5.1.1 Introducing Ratios SB p. 131 TG p. 185	<b>6-A4 Ratio: part to part, part to whole</b> <ul style="list-style-type: none"> <li>• represent ratios with concrete models</li> <li>• understand that ratios are comparisons</li> <li>• compare a part to a whole (e.g., in a group of 6 boys and 4 girls, the ratio 6 : 10 describes the ratio of boys to the whole group)</li> <li>• compare a part to a part (e.g., in a group of 6 boys and 4 girls, the ratio 6 : 4 describes the ratio of boys to girls)</li> </ul>	1 h	None	Q1, 2, 3, 4
5.1.2 Equivalent Ratios SB p. 134 TG p. 188	<b>6-A5 Equivalent Ratios: using models and symbols</b> <ul style="list-style-type: none"> <li>• connect models and symbols to develop multiplicative relationships (e.g., 3 : 5, 6 : 10, 12 : 20, ...)</li> <li>• simplify ratios to make interpretation of situations easier (e.g., <math>36 : 9 = 4 : 1</math>)</li> </ul> <b>6-C5 Equivalent Ratios: change in one term affects the other term</b> <ul style="list-style-type: none"> <li>• explore symbolically how a change in one term of a ratio affects the other</li> </ul>	1 h	None	Q 1, 2, 8
5.1.3 Comparing Ratios SB p. 137 TG p. 191	<b>6-A5 Equivalent Ratios: using models and symbols</b> <ul style="list-style-type: none"> <li>• connect models and symbols to develop multiplicative relationships (e.g., 3 : 5, 6 : 10, 12 : 20, ...)</li> <li>• simplify ratios to make interpretation of situations easier (e.g., <math>36 : 9 = 4 : 1</math>)</li> </ul>	1 h	None	Q 1, 7
5.1.4 EXPLORE: Similarity (Essential) SB p. 140 TG p. 193	<b>6-A6 Similarity: name, describe, and represent</b> <ul style="list-style-type: none"> <li>• understand when shapes are similar (corresponding angles are equal and pairs of corresponding sides are equal multiples of each other)</li> </ul>	1 h	• Rulers	Observe and Assess questions
5.1.5 Introducing Rates SB p. 142 TG p. 195	<b>6-A7 Rates: relating to ratio</b> <ul style="list-style-type: none"> <li>• recognize that rates are just like ratios except that they are comparisons of items in different units</li> <li>• recognize that a rate can be described in more than one way</li> <li>• compare rates</li> </ul>	1 h	None	Q 2, 3, 5

## UNIT 5 PLANNING CHART [Continued]

	Outcomes or Purpose	Suggested Pacing	Materials	Suggested Assessment
<b>Chapter 2 Percent</b>				
<b>5.2.1</b> Introducing Percent <b>SB p. 145</b> <b>TG p. 197</b>	<b>6-A8 Percent: developing benchmarks and number sense</b> <ul style="list-style-type: none"> <li>• understand that percent is a special part-to-whole ratio where the second term is 100</li> <li>• represent percentages pictorially</li> <li>• recognize everyday situations in which percent is used</li> </ul>	1 h	• Hundredths Grids (BLM)	Q 2, 3, 5, 7
<b>5.2.2</b> Representing a Percent in Different Ways <b>SB p. 148</b> <b>TG p. 200</b>	<b>6-A8 Percent: developing benchmarks and number sense</b> <ul style="list-style-type: none"> <li>• use percents as equivalent ratios to make comparisons easier</li> <li>• relate percent and decimal names of ratios (e.g., <math>37\% = 0.37 = 37</math> hundredths)</li> </ul>	1 h	None	Q1, 4, 7
GAME: Ratio Match (Optional) <b>SB p. 150</b> <b>TG p. 201</b>	Practise renaming ratios as percent, fractions, and decimals in a game situation	20 min	• Ratio Match Game Cards (BLM)	N/A
<b>5.2.3 EXPLORE:</b> Writing a Fraction as a Percent (Essential) <b>SB p. 151</b> <b>TG p. 202</b>	<b>6-A8 Percent: developing benchmarks and number sense</b> <ul style="list-style-type: none"> <li>• find percent equivalents for benchmark fractions/ratios such as <math>\frac{1}{4}</math>, <math>\frac{1}{2}</math>, and <math>\frac{3}{4}</math></li> </ul>	1 h	• Hundredths Grids (BLM)	Observe and Assess questions
CONNECTIONS: Map Scales (Optional) <b>SB p. 152</b> <b>TG p. 204</b>	Make a connection between map scales and ratios.	20 min	• Rulers	N/A
UNIT 5 Revision <b>SB p. 153</b> <b>TG p. 205</b>	Review the concepts and skills in the unit	2 h	• Rulers • Hundredths Grids (BLM)	All questions
UNIT 5 Test <b>TG p. 207</b>	Assess the concepts and skills in the unit	1 h	• Hundredths Grids (BLM)	All questions
UNIT 5 Performance Task <b>TG p. 209</b>	Assess concepts and skills in the unit	1 h		Rubric provided
UNIT 5 Blackline Masters <b>TG p. 211</b>	BLM 1 Getting Started Squares BLM 2 Ratio Match Game Cards Hundredths Grids on <b>page 37</b> in UNIT 1			



## Math Background

- Ratio, rate, and percent are relevant to our everyday lives, particularly in terms of buying and selling goods, but also in describing our environment.
- The work in this unit builds on what students already know about multiplication, division, and fractions.
- As students proceed through this unit they will use a variety of mathematical processes, including problem solving, communication, reasoning, representation, visualization, and making connections.

For example:

- Students use problem solving in **question 8** in **lesson 5.1.2**, where they are provided with partial information about the terms of a ratio to solve a problem, in **question 5** in **lesson 5.1.3**, where they solve a problem involving ratios in a mixture, in **question 5** in **lesson 5.1.5**, where they use data to figure out who travelled fastest, and in **question 6** in **lesson 5.2.2**, where they solve a problem involving both percents and other ratios.
- Students use communication in **question 8** in **lesson 5.1.1**, where they describe a situation using many ratios, in **question 7** in **lesson 5.1.3**, where they describe situations where ratio comparison is useful, and in **question 8** in **lesson 5.2.2**, where they explain why the decimal that describes a percent must take a particular form.
- Students use reasoning in **question 5** in **lesson 5.1.1**, where they look at information about parts of different wholes to compare them, in **question 5** in **lesson 5.1.2**, where they test a conjecture about forming equivalent ratios, and in **question 4** in **lesson 5.2.2**, where they relate percents to fractions.
- Students consider representation in **question 3** in **lesson 5.1.1**, where they represent a ratio in different ways, in **question 7** in **lesson 5.1.5**, where they represent a rate in different ways, and in **question 4** in **lesson 5.2.1**, where they represent a percent visually to solve a problem.

- Students use visualization in **question 3** in **lesson 5.1.2**, where they interpret a picture to describe why two ratios are equivalent, in **question 9** in **lesson 5.2.1**, where they use a visual representation of one percent to learn about another percent, and in **question 5** in **lesson 5.2.2**, where they use data displayed in a hundredths grid to draw conclusions about percents.
- Students make connections in **question 6** in **lesson 5.1.3**, where they relate a real-world situation to mathematics, in **lesson 5.1.4**, where they relate the geometric concept of similarity to the numerical concept of ratio, in **question 9** in **lesson 5.1.5**, where they see how rates are used to describe the population of a country, in **question 6** in **lesson 5.2.1**, where they think about how percents can be used to describe aspects of their lives, and in **lesson 5.2.3**, where they connect fractions to percents.

## Rationale for Teaching Approach

- This unit is divided into two chapters.  
**Chapter 1** focuses on ratio and rate.  
**Chapter 2** focuses on percent.
- The first **Explore** lesson emphasizes the connection between the geometric concept of similarity and the numerical concept of ratio. The second **Explore** lesson provides an opportunity for students to begin to think about how fractions that are not hundredths can be renamed to be written as percents. This idea is extended in Class VII.
- The **Connections** relates the concept of map scales to what students have learned about ratio in the unit.
- The **Game** lets students practise relating percents to ratios where the second term is not 100.
- Throughout the unit, the focus is on understanding the meaning of the concepts being taught.

## Getting Started

Curriculum Outcomes	Outcome relevance
4 Hundredths: model and record 4 Hundredths: compare and order 5 Rename Fractions: with and without models 5 Ratio and rate: exploring informally 5 Equivalent fractions: multiplicative relationship 6 Renaming: simple fractions to decimals	Reviewing what students know about fractions and decimals will support them as they learn concepts involving ratio and rate.

Pacing	Materials	Prerequisites
1 h	<ul style="list-style-type: none"> <li>Getting Started Squares (BLM) (optional)</li> </ul>	<ul style="list-style-type: none"> <li>creating repeating patterns</li> <li>identifying and representing fractions</li> <li>creating equivalent fractions</li> <li>identifying and representing decimal hundredths</li> <li>ordering decimals</li> <li>representing a fraction tenth or hundredth as a decimal</li> </ul>

### Main Points to be Raised

#### Use What You Know

- The parts of a repeating pattern can be described using equivalent fractions.
- If a whole is made up of two parts and one part is double (or triple) the other part, the small part is  $\frac{1}{3}$  (or  $\frac{1}{4}$ ) of the whole.
- You can create repeating patterns to represent a wide variety of fractions.

#### Skills You Will Need

- The numerator of a fraction tells how many parts are being counted. The denominator tells the number of equal parts into which a whole has been divided.
- Two fractions are equivalent if they represent the same part of a whole.
- Two fractions are equivalent if the numerators and denominators have been multiplied or divided by the same amount.
- Shading  $x$  squares of a hundredths grid represents the decimal equivalent to  $\frac{x}{100}$ .
- You can order decimal hundredths just like you order whole numbers.
- You can rename a fraction as a decimal by first renaming it as an equivalent fraction with a denominator of 10 or 100.

### Use What You Know — Introducing the Unit

- To complete this activity, students can use the grey and white squares provided in the Getting Started Squares BLM or they can draw their own squares and shade some of them.
- Before assigning the activity, draw four shaded and two unshaded circles on the board. Ask students why you might say the number of shaded circles is twice as many as the number of unshaded circles. Draw two more shaded circles. Ask what words you can use now to describe the relationship between the shaded and unshaded circles (three times as many). Finally, ask students to name the fraction that describes the proportion of the circles that are shaded ( $\frac{6}{8}$  or  $\frac{3}{4}$ ).

Students can work in pairs to complete the activity. While you observe students at work, you might ask questions such as the following:

- Why did you use 9 squares and not 8 squares?* (I needed twice as many grey squares as white squares. If I use 3 white squares, I need 6 grey squares;  $3 + 6 = 9$  and not 8. If I use only 2 white squares, I need 4 grey and the total is 6, not 8.)
- How did you change your pattern?* (I added 4 more white squares and 8 more grey squares.)

- Why do you think the number of grey squares was always even? (Whenever I used 1 white square, I had to use 2 grey squares, so there were always pairs of grey squares.)
- Why do the white squares appear less often in the pattern of **part D**? (This time I had to use 3 grey squares instead of 2, before I could add another white square.)
- What fraction of all your squares is grey? Why do you think that happened? (It is  $\frac{3}{4}$  since for every 4 squares, 1 is white and 3 are grey.)
- How did you decide to make the pattern for  $\frac{4}{5}$ ? (I knew that I wanted 4 grey squares for every 5 squares, so I used 4 grey squares for every 1 white square.)

### Skills You Will Need

- To ensure students have the required skills for this unit, assign these questions.
- Students can work individually.

### Answers

#### A. Sample responses:



ii) 8                  iii) 4                  iv) 12

#### B. Sample response:

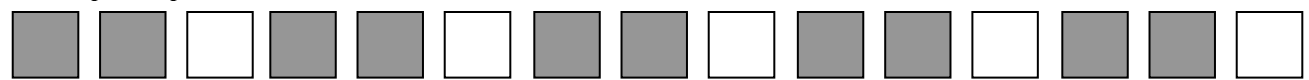

10 grey                  5 white                  15 in all

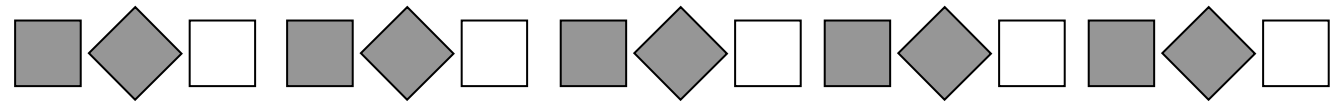

12 grey                  6 white                  18 in all

C. Sample responses: i) All were even numbers                  ii) All were numbers in the 3-times table

#### D. Sample responses:

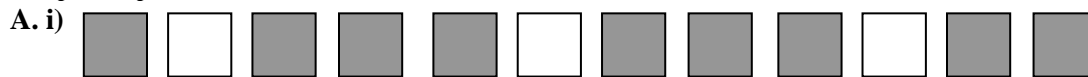

ii) 9                  iii) 3                  iv) 12

#### B.

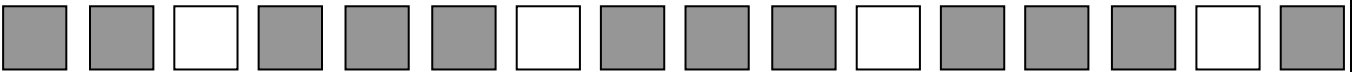

12 grey                  4 white                  16 in all

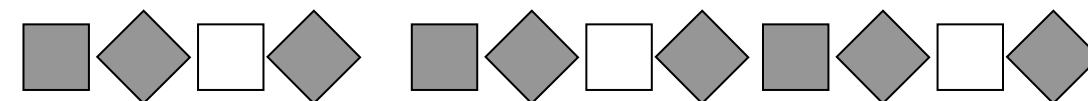
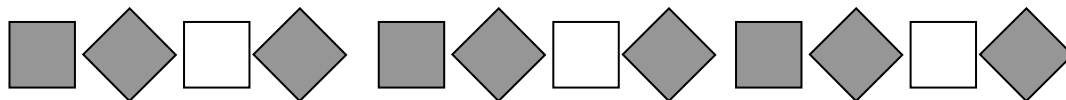

18 grey                  6 white                  24 in all

C. Sample responses: i) All were numbers in the 3-times table                  ii) All were numbers in the 4-times table

**Answers [Continued]**

**E. i) Sample response:**

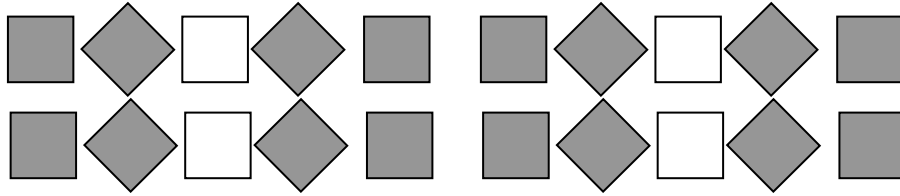

**ii) 4 grey squares for each white square; Sample response:**

If  $\frac{4}{5}$  are grey, there have to be groups of 5 squares. 4 squares in each group are grey. That leaves 1 to be white.

**1. Sample responses: (Equivalent fractions might be used.)**

- a)**  $\frac{6}{15}$       **b)**  $\frac{16}{24}$       **c)**  $\frac{6}{32}$       **d)**  $\frac{12}{36}$

**2. Sample response:**



- 3. a) 6      b) 20      c) 28      d) 45**

- 4. a) 0.46      b) 0.71**

**5. Sample responses:**

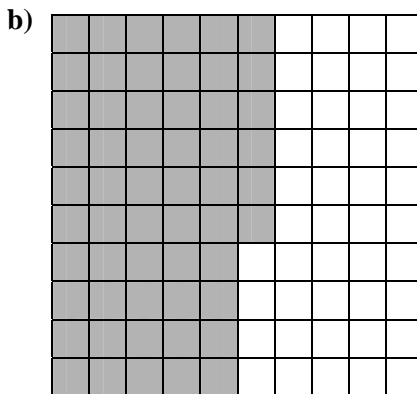
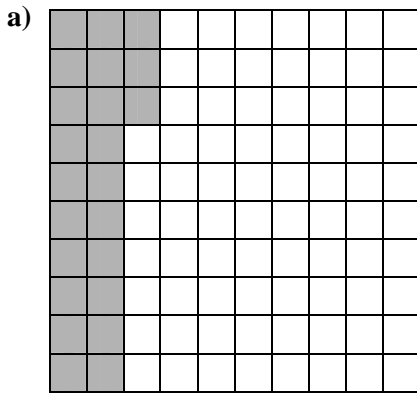

**c)**

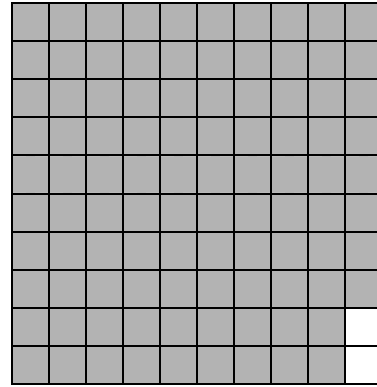

**d)**

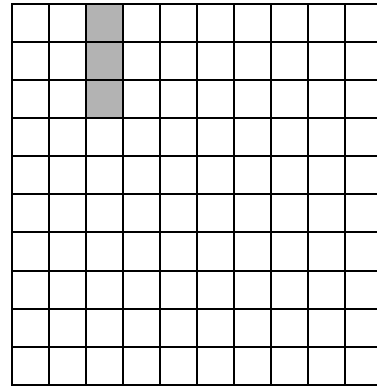

- 6. 0.43, 0.45, 0.58, 0.85**

- 7. a) 0.7      b) 0.5**  
**c) 0.08      d) 0.12**

**Supporting Students**

**Struggling students**

- Some students may need you to re-teach one of these topics: equivalent fractions, representing fractions, or representing decimals. If necessary, work with small groups of students on these prerequisite skills.

**Enrichment**

- Students may wish to create designs on a hundredths grid to match certain decimals, such as a letter of the alphabet that matches the decimal 0.15.

# Chapter 1 Ratio and Rate

## 5.1.1 Introducing Ratios

Curriculum Outcomes	Outcome relevance
<b>6-A4 Ratio: part to part, part to whole</b> <ul style="list-style-type: none"><li>• represent ratios with concrete models</li><li>• understand that ratios are comparisons</li><li>• compare a part to a whole (e.g., in a group of 6 boys and 4 girls, the ratio 6 : 10 describes the ratio of boys to the whole group)</li><li>• compare a part to a part (e.g., in a group of 6 boys and 4 girls, the ratio 6 : 4 describes the ratio of boys to girls)</li></ul>	It is fundamental that students understand ratios to work with percent and also to deal with aspects of everyday life, such as adapting recipes. This is the first formal experience students will have with ratios, although they have already had many informal experiences.

Pacing	Materials	Prerequisites
1 h	None	• identifying fractions of a set or group

### Main Points to be Raised

- A ratio is a way to compare two numbers. The ratio  $a : b$  describes the comparison of  $a$  to  $b$ . It is often read “ $a$  to  $b$ ” or “ $a$  is to  $b$ ”.
- A part-to-part ratio compares a part of a group to another part of a group. A part-to-whole ratio compares a part of a group to the whole group.
- A fraction is an example of a part-to-whole ratio.
- Each part of a ratio is called a *term*; there is a *first term* and a *second term*.
- We use words to describe some ratios. For example, the word *twice* means a 2 : 1 ratio.
- Ratios are common in everyday life, for example, in recipes.

### Try This — Introducing the Lesson

**A.** Allow students to try this alone or with a partner. Observe while students work. To help them get started, you might suggest some things they can compare, e.g., all the white squares to all the squares, the light grey and white squares in one row compared to all the squares in the row, or the white squares in one column to the total number of squares in that column.

While students work, you might ask questions such as the following:

- *Why was your denominator 49?* (I was comparing the white squares to all the squares in the design. There are 49 squares of equal size altogether in the design.)
- *Why was your numerator 2?* (I was comparing the white squares in one of the rows to all the squares in that row. There were only 2 white squares out of 7 squares in that row.)
- *How do you know that the fraction for the white squares was greater than the fraction for the dark grey squares?* (The denominators are the same and there are more white squares than dark grey squares.)

### The Exposition — Presenting the Main Ideas

- Draw 4 shaded and 2 unshaded squares on the board. Tell students that when you write 4 : 2, you are using a ratio to compare the number of shaded squares to the number of unshaded squares. Ask them what they think 2 : 4 means.
- Tell students that 4 : 2 and 2 : 4 are called part-to-part ratios because they compare two parts of the whole group of squares. Ask them what they think 4 : 6 might represent in the picture (the shaded squares compared to the total number of squares). Tell them that this is called a part-to-whole ratio because it compares a part of the group to the whole group. Ask students to suggest another part-to-whole ratio to describe the group (2 : 6).
- Tell students that the number on each side of the colon is called a term of the ratio. The number on the left is called the *first term* and the number on the right is called the *second term*.
- Ask students to suggest a picture you could draw that shows a ratio of 2 : 1. After you draw it (for example, 2 circles and 1 square), point out that the diagram also shows the idea of *twice*.

- Write a simple recipe on the board, e.g., 2 cups of flour, 1 cup of sugar, and  $\frac{1}{4}$  cup of butter. Ask students to create ratios to describe the recipe.
- Have students turn to **page 132** in the student text to see other examples of ratios in our lives.

### Revisiting the Try This

**B.** Students most likely used only part-to-whole ratios in their answer to **part A**. Now they can use both part-to-whole and part-to-part ratios.

### Using the Examples

- Present the question from the example on the board. Ask students to try it and then compare their answers to the solution and thinking in the text..

### Practising and Applying

#### Teaching points and tips

**Q 1:** Students should use both sets of balls (all seven balls) to answer this question.

**Q 2 c):** Students need to think of the fraction as a part-to-whole ratio.

**Q 3:** Students might use the same numbers of items in both pictures, but make them different items, or they might use different numbers of items.

**Q 4:** Students must apply what they have learned about the mathematics to a real-world situation. Technically, there are many possible answers to this question, but students are likely to use only answers that make sense in terms of typical class sizes.

For example, it could be  $64 + 14$  students, but this is not as likely to occur as  $32 + 7$  students.

**Q 5:** Students need to understand that the more white paint there is for each can of green, the lighter the colour.

**Q 7:** Students must recognize that the shapes in the top row are squares.

**Q 8:** Possible ratios could compare people in different generations or people of different genders.

**Q 9:** There are many possible ratios students could use to describe either the people in the class or the classroom itself.

#### Suggested assessment questions from Practising and Applying

<b>Question 1</b>	to see if students can write a ratio to describe a situation
<b>Question 2</b>	to see if students can relate a ratio to the situation it describes
<b>Question 3</b>	to see if students can draw a diagram to represent a particular ratio
<b>Question 4</b>	to see if students can solve a simple problem involving a ratio

### Answers

**A. Sample response:**

$\frac{13}{49}$  describes the white squares in the whole design  
 $\frac{12}{49}$  describes the black squares in the whole design  
 $\frac{7}{49}$  or  $\frac{1}{7}$  describes the number of squares in one row or column of the whole design

**B. Sample response:**

13 : 49 to compare white squares to total squares  
 12 : 49 to describe black squares to total squares  
 7 : 49 to describe the number of squares in the first row compared to the total number of squares  
 13 : 12 to compare the white squares to the black squares in the whole design

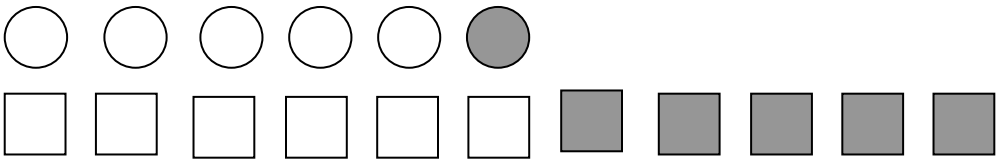
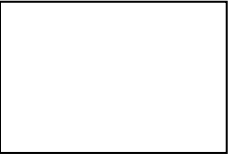
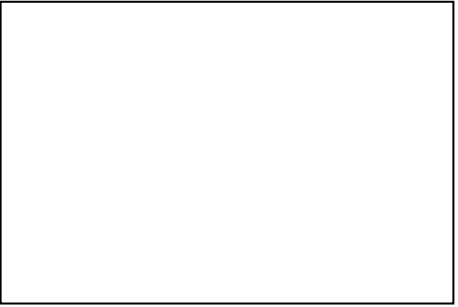
<p>1. a) 3 : 4                      b) 3 : 7</p>	<p>2. a) Grey to white                      b) Striped to grey c) White to total                      d) Striped to white</p>
<p>3. <i>Sample response:</i></p> 	
<p>4. a) Part-to-part; [<i>Sample response:</i> The class is the whole but it has two parts. The residential students form one part and the other students form the other part.] b) 39</p>	<p>5. D; [<i>Sample response:</i> There are more cans of white paint for the same amount of green paint. White makes things lighter.]</p>
<p>6. <i>Sample responses:</i></p> <p>a)                        b) 1 : 2                      c) 1 : 4</p> <p>7. a) 2 : 1                      b) 1 : 2</p> <p>8. <i>Sample response:</i></p> <p>Duptho to family = <math>\frac{1}{6}</math>                      Adults to children = <math>\frac{2}{4}</math>                      Adults to family = <math>\frac{2}{6}</math> Duptho to brother = 1 : 1                      Duptho to sisters = 1 : 2                      Duptho to children = 1 : 4</p>	
<p>9. <i>Sample responses:</i></p> <p>a) 22 : 18 to compare boys to girls 1 : 40 to compare teachers to students 6 : 1 to compare windows to doors b) 7 : 17 to describe the number of hours I am in school compared to the hours I am not on a school day 6 : 7 to compare school days to total days in each week 3 : 1 to compare the other people in the family to me</p>	<p>10. Yes; [<i>Sample response:</i> If there are two parts, you could reverse which part you talk about first, so you would have two different part-to-part ratios. There are also two part-to-whole ratios. If there are 3 boys and 4 girls in a group: • two part-to-part ratios: 3 : 4 and 4 : 3 • two part-to-whole ratios: 3 : 7 and 4 : 7]</p>

## Supporting Students

### *Struggling students*

- Some students may need help with **questions 4, 5, and 8**, which require them to solve problems related to ratios. You may wish to suggest these students work with a partner for these questions.

### *Enrichment*

- Students can create ratio situations like those in **questions 4 and 8** for other students to explore.

## 5.1.2 Equivalent Ratios

Curriculum Outcomes	Outcome relevance
<p><b>6-A5 Equivalent Ratios: using models and symbols</b></p> <ul style="list-style-type: none"> <li>connect models and symbols to develop multiplicative relationships (e.g., 3 : 5, 6 : 10, 12 : 20, ...)</li> <li>simplify ratios to make interpretation of situations easier (e.g., 36 : 9 = 4 : 1)</li> </ul> <p><b>6-C5 Equivalent Ratios: change in one term affects the other term</b></p> <ul style="list-style-type: none"> <li>explore symbolically how a change in one term of a ratio affects the other</li> </ul>	By learning to recognize and create equivalent ratios, students will be able to solve ratio and percent problems.

Pacing	Materials	Prerequisites
1 h	None	<ul style="list-style-type: none"> <li>familiarity with the concept of ratios</li> <li>familiarity with the term <i>perimeter</i></li> </ul>

### Main Points to be Raised

- Different ratios that describe the same relationship are called equivalent.
- A ratio is in lower terms if it is equivalent to a given ratio, but the values of its terms are less.
- You can calculate an equivalent ratio by multiplying the numerator and the denominator by the same amount. You cannot normally add or subtract the same amount to both terms to create an equivalent ratio.

### Try This — Introducing the Lesson

A. Allow students to try this alone or with a partner. While you observe students at work, you might ask questions such as the following:

- What fraction of the 200 mL mixture is sugar? ( $\frac{15}{200}$ )
- What fraction of the 400 mL mixture is sugar? ( $\frac{15}{400}$ )
- Which fraction is greater? How do you know? (The fraction for the 200 mL mixture is greater because a 200th is a larger piece than a 400th. There are 15 of each kind of piece.)
- Is the mixture with the greater fraction of sugar more or less sweet? Why? (More. It is sweeter because there is a greater proportion of sugar in it.)

### The Exposition — Presenting the Main Ideas

- Ask two boys and one girl to stand. Ask students to tell you the ratio of boys to girls that are standing. Talk about the fact that there are twice as many boys as girls. Write the ratio 2 : 1 on the board.
  - Have two more boys and one more girl join the standing students. Ask what the ratio of boys to girls is now. Say that even though the ratio is now written as 4 : 2, there are still twice as many boys as girls. Write the equation  $4 : 2 = 2 : 1$ . Indicate that these ratios are equivalent as they both name the same relationship.
  - Ask students to open their texts to **page 134**. Have them look at the drawings and discuss why the ratios 12 : 3 and 4 : 1 are equivalent. Explain why the form 4 : 1 is called a ratio in lower terms.
  - Show students how the same comparison can be repeated over and over. This will help students see why you can multiply both terms of a ratio by the same amount to get an equivalent ratio.
- For example, draw 3 circles and 2 squares. Repeat the drawing three times. Point out that there are always 3 circles for each group of 2 squares, so the ratio is always 3 : 2, but because there are now 9 circles and 6 squares, the ratio can also be written as 9 : 6.
- Discuss the final example in the exposition with the students to help them understand why you cannot normally add the same number to both terms of a ratio to get an equivalent ratio. Explain how the two diagrams show the ratios 1 : 2 and 5 : 6 ( $1 + 4 : 2 + 4$ ), but the ratio has clearly changed. Instead of there being the same number of grey squares as white squares, there are now five times as many.
  - Check student understanding by asking them to list two ratios that are equivalent to 4 : 5 and two ratios that are not equivalent to 4 : 5.



## Revisiting the Try This

**B.** Students can now recognize why the two ratios in **part A** were not equivalent.

### Using the Examples

- Ask students to work through the two examples in pairs. Students might be interested in knowing that this recipe comes from Haa. Provide an opportunity for them to ask any questions they might have.

### Practising and Applying

#### Teaching points and tips

**Q 3:** You may need to tell students first to first look at a single line of the diagram and then to consider the full diagram.

**Q 4:** Encourage students to use **question 3** as a model.

**Q 5:** Some students will know from the exposition that you cannot add the same amount to both terms. These students may wish to focus on the subtraction part of the question.

**Q 6:** Students can choose to multiply or divide both terms of the given ratios to get equivalent ratios.

**Q 7:** You may have to remind some students what perimeter is. Note that there are many correct answers to this question.

For example, a student could draw a triangle with side lengths of 2 cm, 3 cm, and 3 cm, or a square with any side length.

**Q 8:** Encourage students to try a number of examples.

#### Common errors

- Some students will continue to add or subtract the same amount to both terms of a ratio to create an equivalent ratio. Encourage them to use a picture to see whether the ratios are equivalent.

#### Suggested assessment questions from Practising and Applying

<b>Question 1</b>	to see if students can recognize equivalent ratios
<b>Question 2</b>	to see if students can write a ratio that is equivalent to a given ratio
<b>Question 8</b>	to see if students can make and test a conjecture about equivalent ratios

### Answers

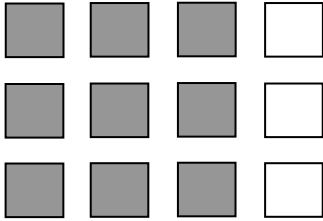
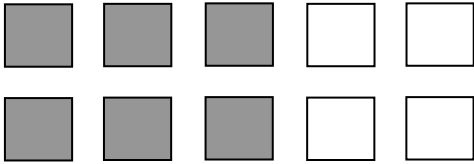
<b>A. i)</b> No	<b>ii)</b> 30 mL	<b>B.</b> 15 : 200 and 30 : 400
<p><b>1.</b> B and D</p> <p><b>2. a)</b> 2                      <b>b)</b> 16  <b>c)</b> 8                         <b>d)</b> <i>Sample response:</i> 7, 4</p> <p><b>3. a)</b> Yes; [3 columns out of 4 are grey = 6 squares out of 8 are grey.]  <b>b)</b> <i>Sample response:</i></p>  <p>[I added another identical row. It shows 3 : 4 = 9 : 12.]</p>	<p><b>4. Sample response:</b></p>  <p>[3 columns out of 5 are grey = 6 squares out of 10 are grey.]</p>	

## Answers [Continued]

5. No;

[Sample response:

3 : 6

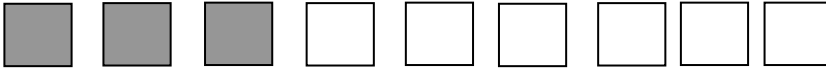

4 : 7

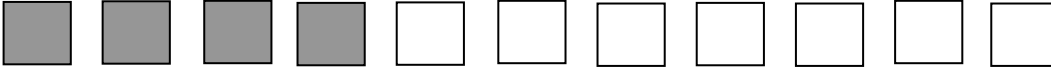

The second ratio was formed by adding 1 to each term of the first ratio.

The first ratio shows that there are twice as many white squares as grey squares but the second ratio shows fewer than twice as many white as grey, so 3 : 6 cannot be equivalent to 4 : 7.]

6. Sample responses:

a) 1 : 1000

b) 1 : 1000

7. Sample response:

A square with a 2 cm side and perimeter of 8 cm; ratio of side length to perimeter is 2 : 8 = 1 : 4.

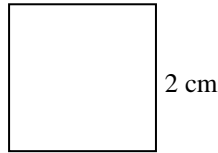

A triangle with 2 cm, 3 cm, and 3 cm sides and perimeter of 8 cm; ratio of base to perimeter is 2 : 8 = 1 : 4.

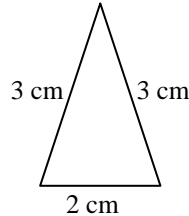

8. No; [Sample response:

If the difference is 5, then the difference for an equivalent ratio is a multiple of 5, so it cannot be 8. For example, for 3 : 8 = 6 : 16 = 9 : 24 = 30 : 80, the differences are 5, 10, 15, and 50.]

[9. Sample response:

To get both an equivalent ratio and an equivalent fraction, you multiply or divide both values by the same amount. They both describe the same relationship between a part and a whole.]

[10. Sample response:

When a ratio is in lower terms, it is easier to visualize. For example, for 2 : 1, I can visualize twice as many grey shapes as white shapes, but for 52 : 26, it is harder to visualize 52 greys for each group of 26 whites.]

## Supporting Students

### Struggling students

- Some students may have difficulty with **questions 3 and 4**, where they have to use a diagram to interpret equivalence. You might explain the concept in **question 3** and ask them to apply what you have modelled as they answer **question 4**.
- You might choose not to assign **question 7** to struggling students. Or, you might have students draw shapes and write the ratio of each side length to the perimeter.

### Enrichment

- Ask students to solve problems involving the terms of equivalent ratios.

For example, say that the terms of a ratio equivalent to 20 : 35 sum to 33. Ask what the ratio is.

## 5.1.3 Comparing Ratios

Curriculum Outcomes		Outcome relevance
<b>6-A5 Equivalent Ratios: using models and symbols</b> <ul style="list-style-type: none"> <li>• connect models and symbols to develop multiplicative relationships (e.g., 3 : 5, 6 : 10, 12 : 20, ...)</li> <li>• simplify ratios to make interpretation of situations easier (e.g., 36 : 9 = 4 : 1)</li> </ul>		Sometimes students are called on to compare ratios, for example, whether the ratio of boys to students in one school is greater than in another school. Students need to be aware of alternative strategies they can use.
Pacing	Materials	Prerequisites
1 h	None	<ul style="list-style-type: none"> <li>• comparing fractions</li> <li>• familiarity with the term <i>perimeter</i></li> </ul>

### Main Points to be Raised

- You can compare two part-to-whole ratios as fractions.
- You can compare part-to-part ratios by comparing related part-to-whole ratios.
- It makes sense to compare ratios only when they describe similar things.

### Try This — Introducing the Lesson

**A.** Allow students to try this alone or with a partner. While you observe students at work, you might ask questions such as the following:

- *How many boys and how many girls will be in the class if a boy joins the class?* (20 boys and 23 girls)
- *How many boys and how many girls will be in the class if a girl joins the class?* (19 boys and 24 girls)
- *What does the fraction  $\frac{20}{43}$  describe?* (The fraction of boys if a boy joins the class.)
- *What does the fraction  $\frac{19}{43}$  describe? What about the fraction  $\frac{19}{42}$ ? How do the two fractions compare?* ( $\frac{19}{43}$  is the fraction of boys if a girl joins the class;  $\frac{19}{42}$  is the fraction of boys before the new student joins the class; the first fraction is less.)

### The Exposition — Presenting the Main Ideas

- Start by drawing on the board one line with 8 circles and 2 squares and another line with 4 circles and 6 squares. Ask which line has the greater proportion of circles.
  - Have the students write the fraction of circles in each line ( $\frac{8}{10}$  and  $\frac{4}{10}$ ) and note how this confirms their conclusion about which line had the greater proportion of circles.
  - Work through the exposition with the students. Make sure they understand why it makes sense that an athlete has a lower ratio of body fat mass to total mass than other people.
  - You may wish to use a diagram to model the colour mixture problem.
- For example, you can model that Can 1 has a ratio of yellow to blue of 3 : 2 by drawing 3 circles marked with a Y and 2 circles marked with a B.
- Discuss why it only makes sense to compare ratios when they describe similar things.

### Revisiting the Try This

**B.** Students can apply the concepts they learned in the exposition to their informal thinking in **part A**.

### Using the Examples

- Present the question in the example to the students. Ask them to try it and then compare their responses to the solution and thinking in the student text.

## Practising and Applying

### Teaching points and tips

**Q 2:** Students need to realize that the paint is darkest if the ratio of green paint to total paint is greatest.

**Q 3:** You may have to remind some students of what perimeter is.

### Common errors

- Some students will compare the parts rather than comparing the part to the whole. This is not a meaningful comparison for students at this stage. Remind them that a fraction always compares parts to a whole.

### Suggested assessment questions from Practising and Applying

<b>Question 1</b>	to see if students can compare related ratios in a simple situation
<b>Question 7</b>	to see if students can communicate about when it makes sense to compare ratios

## Answers

<b>A. i)</b> 20 : 23	<b>ii)</b> 19 : 24	<b>B.</b> The proportion of boys will become higher if a boy joins the class. The proportion of girls will become higher if a girl joins the class.
<b>1. a)</b> B; 22 : 17	<b>b)</b> A; 18 : 22	<b>4.</b> Both groups have the same ratio of sports players; [ $\frac{12}{20} = \frac{3}{5}$ and $\frac{9}{15} = \frac{3}{5}$ .]
<b>2. A;</b> [ <i>Sample response:</i> I compared the fractions $\frac{3}{5}$ , $\frac{3}{7}$ , $\frac{2}{6}$ , and $\frac{6}{15}$ to find the greatest fraction of green. The greatest fraction of green was the darkest paint since there was more green compared to white. $\frac{3}{5} > \frac{3}{7}$ since fifths are bigger than sevenths. So B is not darkest. $\frac{3}{5} > \frac{6}{15}$ since $\frac{3}{5} = \frac{9}{15}$ so D is not darkest. $\frac{3}{5} > \frac{2}{6}$ since $\frac{3}{5} = \frac{18}{30}$ and $\frac{2}{6} = \frac{10}{30}$ . $18 > 10$ so A is darkest.]	<b>5. Package B;</b> [ <i>Sample response:</i> $\frac{200}{350} = \frac{4}{7}$ , which is a bit more than half. $\frac{30}{40} = \frac{3}{4}$ , which is much more than half.]	<b>6.</b> The second music club; [ $\frac{32}{40} = \frac{96}{120}$ and $\frac{25}{30} = \frac{100}{120}$ .]
<b>3.</b> Triangle; [ <i>Sample response:</i> 7 : 20 > 5 : 20]		<b>7. Sample response:</b> To find out whether something will taste the way you expect based on the recipe if you change the amounts of some of the ingredients.

## Supporting Students

### Struggling students

- Most of the work in this lesson involves solving problems in context. For many students, the context will help them solve the problems, but for others it might be best to let them compare some ratios numerically and then apply what they know to solve the problems.

### Enrichment

- Students might work together in small groups to come up with a greater variety of answers to **question 7**.
- Students might also create measurement situations (like in **question 3**) to fit a broad variety of situations.

For example, they could compare the ratio of length to width of rectangles that are long and thin to the ratio of length to width of rectangles that are closer to square.

## 5.1.4 EXPLORE: Similarity

Curriculum Outcomes		Outcome relevance
<b>6-A6 Similarity: name, describe, and represent</b> <ul style="list-style-type: none"><li>• understand when shapes are similar (corresponding angles are equal and pairs of corresponding sides are equal multiples of each other)</li></ul>		This essential exploration allows students to see how the concept of ratio is fundamental to understanding whether two shapes are similar.
Pacing	Materials	Prerequisites
1 h	• Rulers	• familiarity with the notion of enlarging and reducing

### Exploration

<ul style="list-style-type: none"><li>• Explain to students that they will be looking at how the ratios of similar shapes relate.</li><li>• Have students read the introduction (in white) at the top of <b>page 140</b> in the student text, which discusses the contrast between shapes that are similar and shapes that are not similar. The focus of this early definition is on visual comparison rather than using measurements, but a connection is made to using measurements.</li></ul> <p>Encourage students to work in pairs on <b>parts A to F</b>. While you observe students at work, you might ask questions such as the following:</p> <ul style="list-style-type: none"><li>• <i>How do you know the second shape is similar?</i> (It looks like an enlargement.)</li><li>• <i>What did you notice about the diagonals?</i> (The diagonals are twice as long, just like the sides were.)</li><li>• <i>What happened to the perimeter? Why do you think it happened?</i> (The perimeter was three times as long; that makes sense since the perimeter is made up of the side lengths and each side length was three times as long.)</li><li>• <i>How do the length-to-width ratios compare for similar shapes?</i> (They are the same.)</li><li>• <i>How can you see that shapes are not similar by looking at them?</i> (I can see that the length-to-width comparisons are different.)</li><li>• <i>Why are these two squares similar?</i> (One has side lengths of 3 cm and the other has side lengths of 6 cm, so each side length was multiplied by the same amount, 2. Or, the width-to-length ratios are 3 : 3 and 6 : 6, which means they are both 1 : 1.)</li><li>• <i>What ratios relating to similar shapes are equivalent?</i> (The ratios of the lengths, the widths, and the diagonal lengths are equivalent.)</li></ul>
--

### Observe and Assess

As students work, notice the following:



- Can students make good predictions about whether shapes are similar by looking at them?
- Do students measure carefully enough to draw reasonable conclusions?
- Do students calculate required ratios correctly?
- Do students calculate the perimeters correctly?
- Do students understand why all squares are similar?
- Can students describe a test for similarity for rectangles?

### Share and Reflect

After students have had sufficient time to work through the exploration, discuss questions such as these.

- *Suppose you multiply the length and width of a rectangle by 0.5. What measurements are in the ratio 2 : 1?*
- *What other ratios that describe the two rectangles would be equivalent?*
- *Why are all circles similar shapes?*
- *Why is using ratios a better test for similarity than just looking at the shapes?*

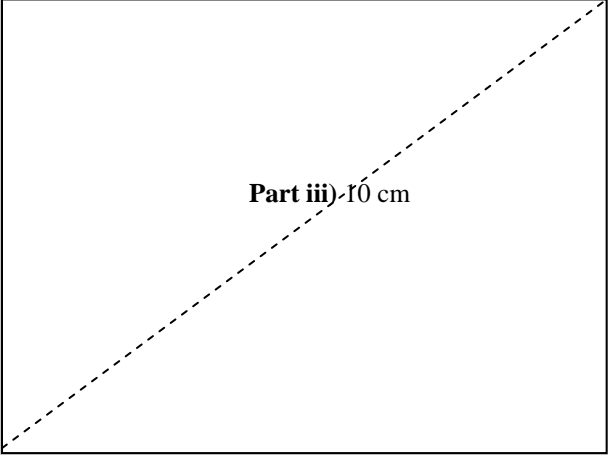
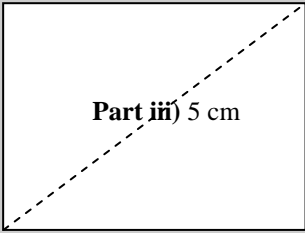
## Answers

<p><b>A. i) Rectangle A</b></p>  <p><b>ii) <math>8 : 4 = 2 : 1</math></b>      <b>iii) <math>10 : 5 = 2 : 1</math></b></p>	<p><b>Rectangle B</b> <i>Sample response:</i></p>  <p><b>iv) They are equivalent.</b></p>
<p><b>B. Sample responses:</b></p> <p><b>i) Rectangle C</b></p>  <p><b>Rectangle D</b></p>  <p><b>ii) <math>6 : 2 = 3 : 1</math></b>  <b>iii) Rectangle C's perimeter is 6 cm; Rectangle D's perimeter is 18 cm, so <math>18 : 6 = 3 : 1</math>.</b>  <b>iv) They are equivalent.</b></p> <p><b>C. Sample responses:</b></p> <p><b>i) Rectangle E is 4 cm by 2 cm; Rectangle F is 6 cm by 2 cm.</b>  <b>ii) <math>4 : 2 = 2 : 1</math> for Rectangle E and <math>6 : 2 = 3 : 1</math> for Rectangle F.</b></p>	<p><b>iii) No; The second terms in both ratios are the same but the first terms are different so they cannot be equivalent ratios; Rectangle F has the same width as Rectangle E, but Rectangle F is longer.</b></p> <p><b>D. Yes; The length is 4 times the width for both rectangles. Or, the sides of the big rectangle are twice the length of the matching sides of the small rectangle.</b></p> <p><b>E. Sample response:</b>  All squares are similar because the ratio of one pair of matching sides is the same for the other pairs of matching sides. All the sides are the same length on each square.</p> <p><b>F. Sample response:</b>  To see if the ratio between matching side lengths is the same, you can use equivalent ratios. For example, if the width of one rectangle is 1 cm and the matching side in the other rectangle is 2 cm, you write the ratio 1 : 2. If you then measure the lengths of both rectangles and write a ratio that is 1 : 2 or 2 : 4 or 3 : 6, and so on, you know the rectangles are similar because 1 : 2, 2 : 4, 3 : 6 and so on are all equivalent ratios.</p>

## Supporting Students

### Struggling students

- Some students will not understand that, even though the length-to-width ratio for each of the two rectangles are equal, they do not have to be equal to the length-to-length ratios for the two rectangles.

For example, a rectangle with length 5 and width 4 has a length-to-width ratio of 5 : 4. If the side lengths are doubled to create a rectangle that is 10 by 8, the length-to-length ratio of the two rectangles is 2 : 1, not 5 : 4.

Make sure students understand that either ratio can be used to test for similarity.

### Enrichment

- Some students might explore the fact that all regular polygons of a particular type are similar, whether equilateral triangles, regular hexagons, or regular octagons.

## 5.1.5 Introducing Rates

Curriculum Outcomes	Outcome relevance
<b>6-A5 Equivalent Ratios: using models and symbols</b> <ul style="list-style-type: none"> <li>connect models and symbols to develop multiplicative relationships (e.g., 3 : 5, 6 : 10, 12 : 20, ...)</li> <li>simplify ratios to make interpretation of situations easier (e.g., 36 : 9 = 4 : 1)</li> </ul>	Equivalent rates are regularly used in consumer mathematics, for example, to compare prices.

Pacing	Materials	Prerequisites
1 h	None	<ul style="list-style-type: none"> <li>calculating equivalent ratios</li> <li>comparing ratios</li> <li>knowing that 60 min = 1 h</li> </ul>

### Main Points to be Raised

- A rate is like a ratio because it compares quantities called terms. In a rate, each term has a different unit.
- There are equivalent rates that describe the same comparison, just like there are equivalent ratios. To create an equivalent rate, you multiply or divide both terms of the rate by the same value.
- The word *per* is used to mean “for each” in a rate. The symbolic abbreviation is the slash (/).
- If the second term of a rate is 1, the rate is called a unit rate.
- In our everyday lives we encounter rates such as speeds, which can compare distance to time. Other rates relate prices of items purchased in quantities. For example, 3 candies for Nu 20, and wages such as Nu 100 per hour.
- Rates can be compared in the same way as ratios.

### Try This — Introducing the Lesson

**A.** Allow students to try this alone or with a partner. While you observe students at work, you might ask questions such as the following:

- Why did you divide 5 by 5? (I divided 30 by 5 to get 6 minutes, so I also have to divide the distance by 5.)*
- Why did you multiply instead of dividing to calculate the number of minutes? (The distance is twice as many kilometres, so it would take two times as much time. I had to multiply.)*
- How long would it take for Chandra to go 15 km? 2 km? (For 15 km, I need to multiply 30 minutes by 3. For 2 km, I need to divide 30 min by 5 to get the time for 1 km and then double that time.)*

### The Exposition — Presenting the Main Ideas

- Ask students for examples of situations when they have seen prices in a store listed for more than one item, for example, where the price given is for two, three, or four items.
- Have students turn to **page 142** in their texts. Have them look at the price for the 4 apples. Ask students if they can tell from that price what the price is for 1 apple, for 8 apples, and for 2 apples.
- Work through the exposition with the students. Make sure they understand how to record a rate using the slash sign, i.e., 4 apples/Nu 20. Discuss how it could also be written as Nu 20/4 apples.
- Encourage students always to write the units with the terms of the ratio.
- To ensure that students understand the concepts of equivalent rates and rate comparisons, ask students to find another way to write the typing rate 50 words/minute. Then ask how this rate would compare to the typing rate of 10 words/10 minutes.

### Revisiting the Try This

**B.** Students should recognize why the situation in **part A** is a rate situation.

### Using the Examples

- Ask students to work through the examples in pairs. One of the pair should become an expert on **example 1** and the other an expert on **example 2**. Each should then explain his or her example to the other student.

## Practising and Applying

### Teaching points and tips

**Q 1:** Students might choose to use equivalent rates, for example, unit rates, or they might use the numbers exactly as given in the problem.

**Q 2:** Students need to use the fact that there are 60 min in 1 h and 7 days in 1 week.

**Q 4:** Students might have difficulty changing 120 beats in 30 s to a unit rate in beats per minute. They might

instead think of it as 120 beats in  $\frac{1}{2}$  min.

**Q 6:** Students need to understand that they can rename any rate by switching the first and second terms.

**Q 9:** This question provides a good opportunity for students to see some of the many ways rates are used to describe our world.

### Common errors

- Some students have difficulty comparing rates with the same first term and different second terms.

For example, to compare 50 km/2 h to 50 km/1 h, they might assume that the first rate is greater, when, in fact, the second rate is greater.

Students may choose always to use equivalents where the second terms are the same. A preferable alternative is for you to work through many of these situations along with students so they become comfortable with them.

### Suggested assessment questions from Practising and Applying

<b>Question 2</b>	to see if students recognize equivalent rates
<b>Question 3</b>	to see if students can calculate equivalent rates
<b>Question 5</b>	to see if students can compare rates

### Answers

A. i) 1	ii) 60	B. It compares distance travelled to time.
<p><b>1. Sample responses:</b> a) 70 km/1.5 h    b) Nu 170/2 kg    c) Nu 20/12 bananas</p>		<p><b>b) Sample response:</b> 36 km/h; 72 km/2 h; 9 km/15 min</p>
<p><b>2. B and D</b></p>		<p><b>7. Sample response:</b> Nu 9000/2 months; Nu 27,000/6 months; Nu 54,000/year</p>
<p><b>3. a) 150          b) 25          c) 2</b></p>		<p><b>8. Sample response:</b> 1 year/900 million people; 300 million people/4 months; 450 million people/6 months</p>
<p><b>4. a) Large dog      100 beats/1 min</b> Lion                  40 beats/1 min Elephant            35 beats/1 min Chicken              240 beats/1 min</p> <p><b>b) Elephant, lion, dog, chicken</b></p>		<p><b>[9. Sample responses:</b> <b>a)</b> If you know how many thousand people there are, you can multiply by 34 to estimate the number of births each year. <b>b)</b> If you know how many hundred people there are, you can multiply by 47 to estimate how many people can read and write.]</p>
<p><b>5. Karma</b></p>		
<p><b>6. [a]</b> It is the same description — the same number of minutes compared to the same distance.]</p>		

## Supporting Students

### Struggling students

- Although this work on rates can serve as a review for students who are still not confident with equivalent ratios and ratio comparison, for some students it may be better to go back and clarify some of the misconceptions they have about ratios before moving forward with work on rates.
- You might choose to handle **question 9** as a group rather than asking students to work on it individually.

### Enrichment

- Some students might use Bhutanese census data to look for other rates that describe the country or the population. They could write these rates in equivalent form.



## Chapter 2 Percent

### 5.2.1 Introducing Percent

Curriculum Outcomes	Outcome relevance
<b>6-A8 Percent: developing benchmarks and number sense</b> <ul style="list-style-type: none"><li>• understand that percent is a special part-to-whole ratio where the second term is 100</li><li>• represent percentages pictorially</li><li>• recognize everyday situations in which percent is used</li></ul>	Percents are very important in commercial math, as well as in understanding and describing many situations in our everyday lives.

Pacing	Materials	Prerequisites
1 h	• Hundredths grids (BLM)	• creating equivalent fractions

#### Main Points to be Raised

- A percent is a part-to-whole ratio where the second term is 100. You write it by writing the first term followed by the sign %.
- You can visualize a percent on a 10-by-10 grid since each square of the grid represents 1%.
- You can write a ratio where the second term is not 100 as an equivalent percent.
- It is easy to compare ratios written as percents; because the second terms are the same, you need to compare only the first terms.
- Percents are frequently used to describe populations.

#### Try This — Introducing the Lesson

A. Allow students to try this alone or with a partner. While you observe students at work, you might ask questions such as the following:

- *What other ratio could you have written?* (I could have written either 62 : 100 or 100 : 62.)
- *Why did it not make sense to include the 4000 in the ratio?* (I could not really compare 62 to 4000 because 62 was out of every 100 km, not out of the 4000 km.)
- *How did you estimate?* (I figured that there are 40 groups of 100 km in 4000 km, so I multiplied 62 by 40.)

#### The Exposition — Presenting the Main Ideas

- Write the ratio 14 : 100 on the board. Ask students to read it. Inform them that because the second term is 100, there is another way to write this ratio. It is written 14% and read as “fourteen percent”. Tell them that the percent sign replaces the “: 100” and that writing a percent is, in fact, writing a ratio.
- Have students turn to **page 145** of their texts to see a picture of 14% (the percent of the grid that is shaded grey) as well as a picture of 42% (the percent of the grid that is coloured black). Ask students what percent of the grid that is unshaded, to emphasize that the total must be 100%.
- Ask students how many squares could be shaded to make 50%. Talk about why the ratio 1 : 2 is another way to write this percent since 1 out of every 2 squares is shaded. Show them that 1 : 2 is equivalent to 50 : 100 since each term is multiplied by 50.
- Now they can look at the grid on **page 145** to see why 6 : 10 is equivalent to 60%.
- Ask students what grids showing 48% or 54% would look like. Discuss how they know that more of the grid is shaded for 54% than for 48% even before they do the shading. Point out how this shows why it is easy to compare percents.
- Have students note the list of situations on **page 146** in which percents are used.

#### Revisiting the Try This

B. Students can now write at least one of the ratios in **part A** as a percent. In later lessons, they will learn how to calculate the percent they estimated in **part A**. Here you might simply point out that 62% of 4000 is the number they estimated.

## Using the Examples

• Present the problem from the example to the students. Ask them to try it. They can then compare their work to the two solutions shown in the student text. Help the students understand that the diagram in **solution 1** was based on dividing the grid into 5 sections of 20 (each section is made up of 2 columns) and shading the first 5 squares in each section. Discuss how **solution 2** reminds them that, to write an equivalent part-to-whole ratio, they can use equivalent fractions.

## Practising and Applying

### Teaching points and tips

**Q 2:** Provide hundredths grids for students to use. If these are unavailable, they can describe the grids rather than drawing them.

**Q 4:** This is the first time students will use one percent to create another percent. They can use visual clues or work numerically to get the percent for the Atlantic Ocean. You might follow up by asking what percent of the earth's surface area is covered by the other oceans.

**Q 5 and 6:** These questions are designed to help students think about benchmark percents, which are percents to which they can relate new situations.

Answers to **question 5 b) and d)** might vary a little; answers to **questions 6 b), c), or d)** might vary more.

**Q 7:** Students may solve the problem by writing all four values as percents or all four as fractions.

**Q 8:** You might discuss this question with the class as a whole.

**Q 9:** Students must recognize that if a percent of a whole describes one part of the whole, they automatically know the percent that describes the rest of the whole.

### Suggested assessment questions from Practising and Applying

<b>Question 2</b>	to see if students can represent a percent on a diagram
<b>Question 3</b>	to see if students can relate percents to fractions
<b>Question 5</b>	to see if students have a good sense of what 0% and 100% are
<b>Question 7</b>	to see if students can order percents

## Answers

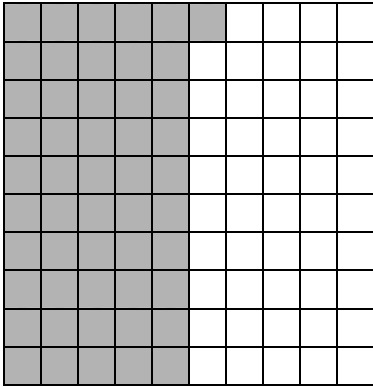
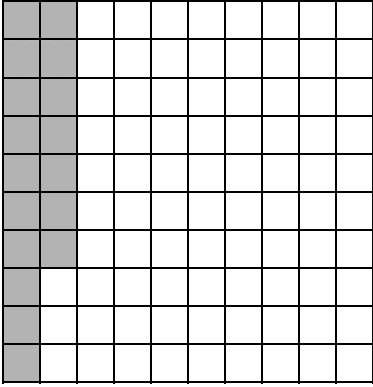
<b>A. i)</b> Sample response: 62 : 100 <b>ii)</b> Sample response: About 2500 km	<b>B.</b> 62%
<b>1. a)</b> 35%; 65% <b>b)</b> 32%; 68%	<b>b)</b>
<b>2. a)</b> 	

2. c)

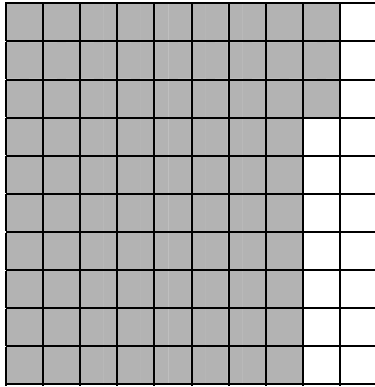

3.

	Ratio	Fraction	Percent
12 to 100	12 : 100	$\frac{12}{100}$	12%
$\frac{91}{100}$	91 : 100	$\frac{91}{100}$	91%
0.01	1 : 100	$\frac{1}{100}$	1%
50 out of 100	50 : 100	$\frac{50}{100}$	50%

4. *Sample response:*

Grey for Pacific Ocean, black for Atlantic Ocean, and striped for other water.

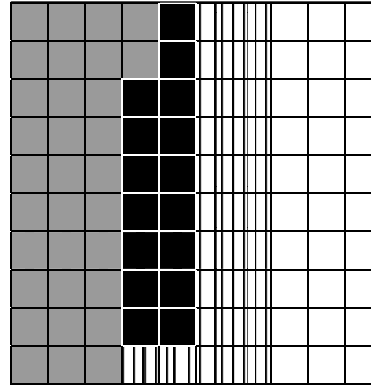

5. a) 100%      b) *Sample response:* 99%  
c) 0%          d) *Sample response:* 2%

6. *Sample responses:*

a) 50%      b) 70%      c) 90%      d) 90%

7. 1 out of 10, 16%, 2 out of 10, 22%

8. *Sample response:*

Marks on tests; in the newspaper when it talked about the results of a survey; in a bank to show interest earned or charged.

[9. *Sample responses:*

a) A 10-by-10 grid has 100 sections and percents are out of 100.

b) If you shade a certain percent, you are leaving another percent unshaded.]

## Supporting Students

### *Struggling students*

- Some students will have difficulty representing the percent for the Atlantic Ocean in **question 4**. Encourage them to use the grid. Once they have represented the portion for the Pacific Ocean, they need to find a portion that is half that size for the Atlantic Ocean.

- Some students will not be comfortable with **question 6**.

For example, they might not feel they can even guess what percent of people eat breakfast.

Encourage them to use their own experience. As long as they can justify the percent they used, that is acceptable.

- Some students may have trouble thinking of the answer to **question 9**, but they will probably be able to understand it once it is presented to them.

### *Enrichment*

- Students might enjoy creating situations to match percents, as is done in **question 6**.

For example, you might ask them to consider when 25% or 75% or 30% describes a real-world situation.

## 5.2.2 Representing a Percent in Different Ways

Curriculum Outcomes	Outcome relevance
<b>6-A8 Percent: developing benchmarks and number sense</b> <ul style="list-style-type: none"> <li>• use percents as equivalent ratios to make comparisons easier</li> <li>• relate percent and decimal names of ratios (e.g., <math>37\% = 0.37 = 37</math> hundredths)</li> </ul>	Students who can flexibly switch between fractions, decimals, and percents will have more tools available to them to solve percent problems.

Pacing	Materials	Prerequisites
1 h	None	<ul style="list-style-type: none"> <li>• familiarity with decimal hundredths</li> <li>• creating equivalent fractions</li> <li>• familiarity with multiples of 5</li> </ul>

### Main Points to be Raised

- A percent can be represented as a fraction and as a decimal.
- The form you use to represent a comparison might depend on the situation.

### Try This — Introducing the Lesson

A. Allow students to try this alone or with a partner. While you observe students at work, you might ask questions such as the following:

- *Is the fraction more or less than  $\frac{1}{2}$ ? How do you know?* (More than  $\frac{1}{2}$  because  $\frac{1}{2}$  is 50% and 70% is more.)
- *What percent is  $\frac{1}{4}$ ?* (25%)
- *How can knowing that 25% is  $\frac{1}{4}$  help you estimate a fraction for 70%?* (Three groups 25% make 75%, which is close to 70%. Three groups of  $\frac{1}{4}$  make  $\frac{3}{4}$ , so  $\frac{3}{4}$  is close to 70%.)

### The Exposition — Presenting the Main Ideas

- Have students read through the exposition on **page 148** of the student text. Provide time for them to ask questions.
- Point out that the example showed changing a fraction to a percent because this is the way it is usually done, but that you can also compare ratios by changing a percent to a fraction.

For example, to compare 19% to  $\frac{1}{2}$ , think of 19% as about 20%, which is  $\frac{1}{5}$ . You can see that  $\frac{1}{5}$  is less than  $\frac{1}{2}$ .

### Revisiting the Try This

B. This question asks students to think of a percent both as a fraction and as a decimal.

### Using the Examples

- Present the problem from the **example**. Students can check their work against the **solution** in the student text.

### Practising and Applying

#### Teaching points and tips

**Q 1:** Some students might find it easier to write the decimal first.

**Q 2:** Students must remember to remove the decimal point when they write the decimal as a percent.

**Q 4:** Students might compare  $\frac{85}{100}$  and  $\frac{3}{4}$  or they might write  $\frac{3}{4}$  as a percent and then compare the percents.

**Q 5:** Students need to recognize that the multiples of 5 appear in the 5 and 10 columns. They will observe that 2 columns of 10 make up 20% of the grid.

**Q 6:** Some students will not recognize that they must first create the part-to-whole ratios to answer the question. Once they do, the question will be easier, although it will still be challenging for some students.

### Common errors

- Some students will mistakenly write the percent in **question 6** using the 3 as a whole. Suggest that they first draw a picture.
- Some students forget to remove the decimal point when they move from a decimal hundredth to a percent. Remind them that percent means hundredths.

### Suggested assessment questions from Practising and Applying

<b>Question 1</b>	to see if students can relate percents to fractions and decimals
<b>Question 4</b>	to see if students can compare a percent to a fraction
<b>Question 7</b>	to see if students can solve a simple problem involving percents

### Answers

<b>A. Sample response:</b> About $\frac{70}{100}$	<b>B. i)</b> 0.7 <b>ii)</b> $\frac{2}{3}$ is about $\frac{66}{100}$ and that is close to $\frac{70}{100}$ .
<b>1. a)</b> $\frac{33}{100}$ and 0.33 <b>b)</b> $\frac{80}{100}$ and 0.80 <b>c)</b> $\frac{15}{100}$ and 0.15 <b>d)</b> $\frac{68}{100}$ and 0.68 <b>2. a)</b> 39% <b>b)</b> 18% <b>3.</b> $\frac{91}{100}$ and 0.91 <b>4.</b> More; [ $\frac{3}{4} = \frac{75}{100} = 75\%$ , and $85\% > 75\%$ .]	<b>5.</b> 20%; [There are 20 multiples of 5 out of 100 numbers.] <b>6. a)</b> 60% <b>b)</b> 5 parts; [If it were 2 : 8, the ratio of blue to total would be 8 : 10, which is 80%, so there would need to be 2 red and 8 blue for a total of 10 parts.] <b>7.</b> 21 girls <b>[8. Sample response:</b> Percent is out of 100, so it is written with hundredths, which use 2 decimal places.]

### Supporting Students

#### Struggling students

- Struggling students may have difficulty with **question 6**. Have them use diagrams and work with a stronger partner. Or, you may choose not to assign this question to students with considerable difficulties.

#### Enrichment

- Students might use percents to classify numbers, as was done in **question 5**. For example, numbers with the digit 1 in them make up 19% of the hundredths grid.

## GAME: Ratio Match

- The cards for the game are found on a BLM on **page 211** of this guide.
- The purpose of the game is to help students practice seeing the relationship between percents and other ratios where the second term is not 100.
- It is important that the cards be arranged in an orderly array so students will remember where particular cards were located from previous turns.

## 5.2.3 EXPLORE: Writing a Fraction as a Percent

Curriculum Outcomes		Outcome relevance
<b>6-A8 Percent: developing benchmarks and number sense</b> • find percent equivalents for benchmark fractions/ratios such as $\frac{1}{4}$ , $\frac{1}{2}$ , and $\frac{3}{4}$		This essential exploration will help students relate some of the more commonly-used fractions to their percent equivalents. Students will then be able interpret the meaning of percents they encounter.
Pacing	Materials	Prerequisites
1 h	• Hundredths Grids (BLM)	• creating equivalent fractions

### Exploration

• Explain to students that they will be looking at how fractions with denominators other than 100 are written as percents. This will help them relate percents they encounter to fractions they already know.

Encourage students to work in pairs. Provide hundredths grids for them to use. While you observe students at work, you might ask questions such as the following:

- *How did you get an equivalent fraction for  $\frac{1}{4}$ ? (I multiplied the denominator by 25 to get 100, so I also had to multiply the numerator by 25.)*
- *Why might it be easier to see the  $\frac{1}{4}$  if you use the top left group of 25 squares? (Then it is easy to see four sections — top right, top left, bottom right, and bottom left.)*
- *Why is this  $\frac{1}{5}$ ? (There are 5 groups of 20 squares.)*
- *Why is this  $\frac{1}{20}$ ? (There are 20 groups of 5 squares.)*
- *How does knowing the percent for  $\frac{1}{20}$  help you find the percent for  $\frac{7}{20}$ ? (I can multiply the 5% by 7 to get 35%.)*
- *Why is  $\frac{1}{3}$  not exactly 33%? (33% is a little less than  $\frac{1}{3}$  because 3 groups of 33 are only 99, not 100.)*

### Observe and Assess

As students work, notice the following:

- Do they model the fractions correctly?
- Do they easily see the relationship between the number of squares and the fraction?
- Do they use what they have learned in one situation to help them with the next situation?

For example, do they immediately realize that  $\frac{1}{10}$  is half as much as  $\frac{1}{5}$ , but twice as much as  $\frac{1}{20}$ ?

### Share and Reflect

After students have had sufficient time to work through the exploration, discuss questions such as these.

- *Why is it useful to memorize percent equivalents for some common fractions?*
- *How does knowing the percents for fractions like  $\frac{1}{4}$  and  $\frac{1}{5}$  help you understand how much 22% is?*

## Answers

A. i)  $\frac{25}{100}$

ii) 25% ; *Sample response:*

If each section is a 5-by-5 square, there are 4 sections, so 1 out of 4 sections is white.

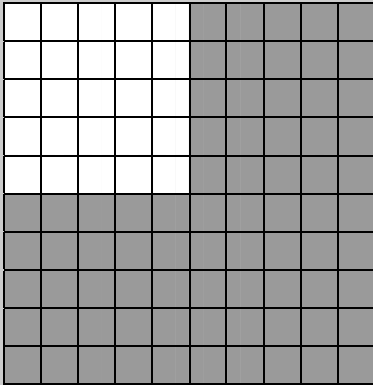

B.  $\frac{1}{2} = \frac{50}{100} = 50\%$

*Sample response:*

If each section is 5 columns, there are 2 sections and 1 out of 2 sections is white.

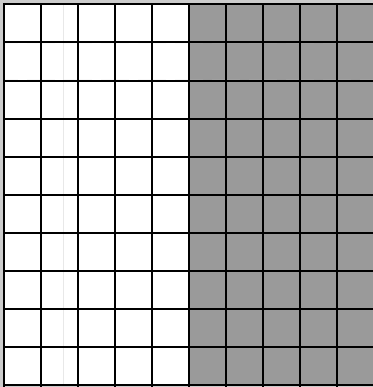

$\frac{1}{5} = \frac{20}{100} = 20\%$

*Sample response:*

If each section is 2 columns, there are 5 sections and 1 out of 5 sections is white.

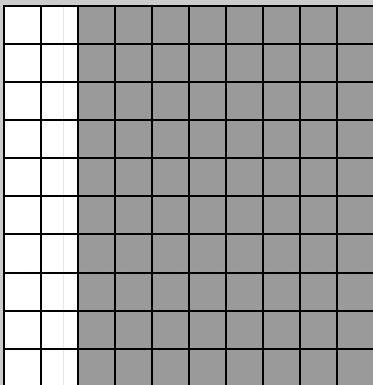

$\frac{1}{10} = \frac{10}{100} = 10\%$

*Sample response:*

1 column out of 10 columns is white.

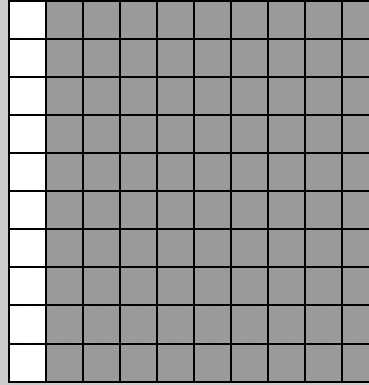

$\frac{1}{20} = \frac{5}{100} = 5\%$

*Sample response:*

If each section is half a column, there are 20 sections and 1 out of 20 sections is white.

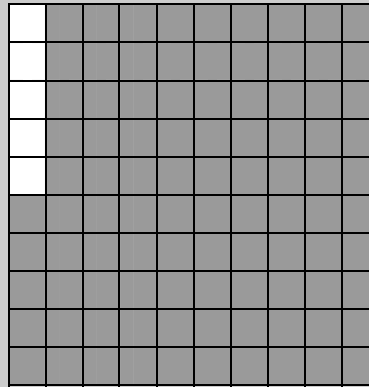

$\frac{1}{25} = \frac{4}{100} = 4\%$

*Sample response:*

If each section is 4 squares, there are 25 sections and 1 out of 25 sections is white.

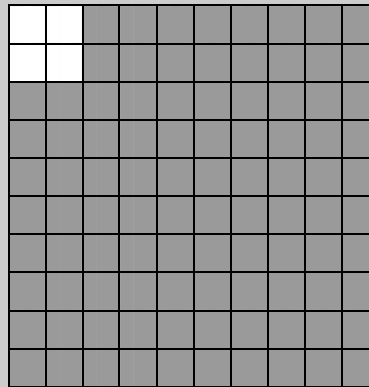

## Answers [Continued]

$$\frac{1}{50} = \frac{2}{100} = 2\%$$

*Sample response:*

If each section is 2 squares, there are 50 sections and 1 out of 50 sections is white.

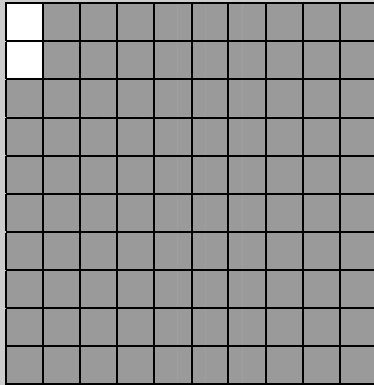

**C. Sample responses:**

**i)** Multiply the percent for  $\frac{1}{4}$ , which is 25%, by 3.

$$3 \times 25\% = 75\%$$

$$\text{ii) } \frac{3}{5} = 3 \times 20\% = 60\%$$

$$\frac{4}{5} = 4 \times 20\% = 80\%$$

$$\frac{2}{5} = 2 \times 20\% = 40\%$$

$$\frac{4}{10} = 4 \times 10\% = 40\%$$

$$\frac{6}{10} = 6 \times 10\% = 60\%$$

**D.** I cannot create an equivalent fraction for  $\frac{1}{3}$  with a denominator of 100.

## Supporting Students

### *Struggling students*

- Most students will have no difficulty with fourths, halves, and tenths, but they might need support for fifths, twentieths, twenty-fifths, and fiftieths — they need to see how they can divide the whole grid into 5, 20, 25, or 50 sections, respectively.

### *Enrichment*

- Some students might be ready to explore other fraction/percent equivalents that are less obvious, for example, eighths, fortieths, or sixths.

## CONNECTIONS: Map Scales

- This connection is designed to help students focus on the role of ratios in creating and interpreting maps. You may need to briefly review the relationships between different length units.

**1. a)** 6 km

**b)** 3 km

**2.** 6 : 30,000,000;

[6 cm represents 300 km.

300 km = 300,000 m

300,000 m = 30,000,000 cm]



# UNIT 5 Revision

Pacing	Materials
2 h	<ul style="list-style-type: none"> <li>• Rulers</li> <li>• Hundredths Grids (BLM)</li> </ul>

Question(s)	Related Lesson(s)
1 – 3	Lesson 5.1.1
4 – 6	Lesson 5.1.2
7 and 8	Lesson 5.1.3
9	Lesson 5.1.4
10 – 14	Lesson 5.1.5
15 – 17	Lesson 5.2.1
18 and 19	Lesson 5.2.2
20	Lesson 5.2.3

## Revision Tips

**Q 2:** Some students might use two different sets of objects to show part-to-part ratios, while others might use one part-to-part picture and one part-to-whole picture.

**Q 4 d):** This might be difficult for students until they try to write the ratio as a fraction. You may need to suggest they could change the fraction to an equivalent fraction.

**Q 8:** Students will need to use equivalent fractions to solve this. There is more than one approach, but one possibility is to compare 24 : 100 to 24 : 90.

**Q 10:** Students may need to use several steps to complete this question.

**Q 19:** You may have to help students who do not know much about sports to realize what it means to do well compared to another team.

## Answers

1. a) *Sample response:* Grey to white  
 b) *Sample response:* Striped to grey  
 c) *Sample response:* Grey to all squares  
 d) White to all squares

2. *Sample response:*



[3 white square to a total of 4 squares]



[3 white squares to 4 grey squares]

3. *Sample response:*

- 5 : 4 to compare rolls of 1 to rolls of 2.  
 5 : 30 to compare rolls of 1 to total rolls.  
 8 : 5 to compare rolls of 5 to rolls of 4.  
 $\frac{11}{30}$  of the rolls were even numbers.

4. a) 3                      b) 6                      c) 12  
 d) *Sample response:* 22 and 6

5. *Sample responses:*

a) 2 columns out of a total of 3 columns are white; 4 squares out of a total of 6 squares are white.

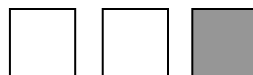

b) In the first row, more than half are white and the white : total ratio is 4 : 6. In the second row, only half are white and the white : total ratio is 4 – 2 : 6 – 2 = 2 : 4, so it cannot be the same comparison as the first row.

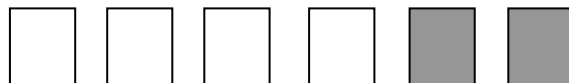

6. a) 21 : 1

b)

Milk	21	42	63	84
Butter	1	2	3	4

**Answers [Continued]**

**7.** Can B; [In Can B,  $\frac{3}{4}$  of the paint is blue, but in Can A, only  $\frac{2}{3}$  is blue.  $\frac{3}{4} > \frac{2}{3}$ .]

**8.** The group of 30 teachers.

**9. Sample response:**  
20 cm, 20 cm, and 8 cm or 5 cm, 5 cm, and 2 cm.

**10.** 6 chocolate bars for Nu 450; [*Sample response:* 3 bars for Nu 250 is the same as 6 for Nu 500 and that is more expensive than 6 for Nu 450. If 5 bars cost Nu 400, 1 bar costs Nu 80. At that rate, 6 bars would cost Nu 480. So 6 bars for Nu 450 is the best price.]

**11.** 122.5 km

**12.** 30 chances

**13.** C

**14. Sample response:** 10 boxes for Nu 800

**15. a)** 25%; 75%      **b)** 60%; 40%

**16. a)**

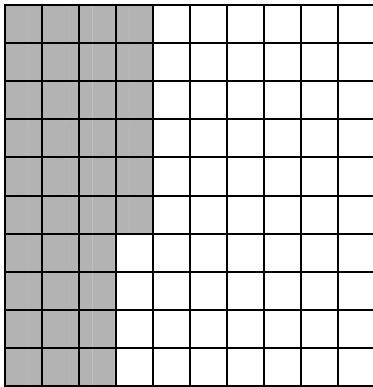

**b)**

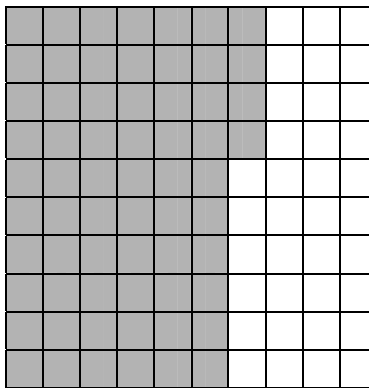

**c)**

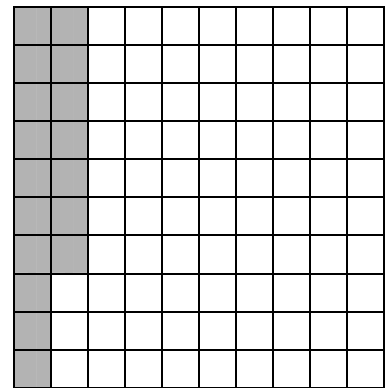

**17. a)** A is reasonable;  
[*Sample response:* Anyone born in Bhutan with a Bhutanese father is Bhutanese. That would mean most people. 100% means all babies.]  
B is reasonable; [*Sample response:* about half of all people are male and half are female. ]  
C is not reasonable; [*Sample response:* the sun always sets in the west. It should be 100% of the time.]  
**b)** *Sample response:* 100% of my sisters are girls.

**18.**

	Ratio	Fraction	Percent
35 to 100	35 : 100	$\frac{35}{100}$	35%
$\frac{65}{100}$	65 : 100	$\frac{65}{100}$	65%
0.60	60 : 100	$\frac{60}{100}$	60%
82 out of 100	82 : 100	$\frac{82}{100}$	82%

**19.** One of the better teams; [it won more than half of its games.]

**20. a)**  $\frac{28}{100}$

**b)** 28%

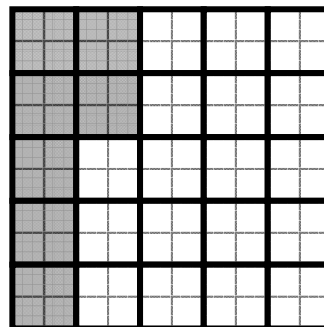

## UNIT 5 Ratio, Rate and Percent Test

1. **a)** Draw a picture to show the ratio 5 : 4.  
**b)** List three or more other ratios the picture shows. Explain how the picture shows each ratio.

2. A school bag holds 4 books, 1 pencil box with 8 pencils in it, and 1 water bottle. Describe the contents of the bag using two or more ratios. Tell what each ratio describes.

3. What are the missing terms?

**a)**  $20$  to  $15 = 4$  to  $\square$

**b)**  $6 : 7 = \square : 42$

**c)**  $5 : 3 = \square : 18$

**d)**  $7 : 21 = 35 : \square$

4. Dechen puts 2 spoonfuls of honey into a recipe that serves 4 people. How much honey does she need if she wants to serve 10 people?

5. Which mixture tastes sweeter?

How do you know?

- A.** 5 g of sugar in 250 mL of water  
**B.** 8 g of sugar in 350 mL of water

6. Group A has 30 students, and 8 students are less than 10 years old. Group B has 20 students, and 6 students are less than 10 years old. Which group has a greater ratio of students that are less than 10 years old? How do you know?

7. Draw two rectangles that are similar. Explain how you know they are similar.

8. Which is the best price for the buyer? How do you know?

- 3 chocolate bars for Nu 144
- 5 chocolate bars for Nu 200
- 6 chocolate bars for Nu 300

9. **a)** Shade one hundredths grid to show 12% and 26%.

**b)** What percent of the grid is not shaded?

10. Which percent below do you think is less than one half?

- A.** the percent of Bhutanese people who live in Asia  
**B.** the percent of Bhutanese children who have brothers  
**C.** the percent of Bhutanese children who have travelled outside of Bhutan

11. Write each value as a percent, as a decimal, and as a fraction.

**a)** 15%

**b)** 0.48

**c)**  $\frac{3}{5}$

12. Use a grid to show why your answer to **question 11 c)** is correct.

13. Which value in **question 11** is greatest? How do you know?

# UNIT 5 Test

Pacing	Materials
1 h	• Hundredths Grids (BLM)

Question(s)	Related Lesson(s)
1 and 2	Lesson 5.1.1
3 and 4	Lesson 5.1.2
5 and 6	Lesson 5.1.3
7	Lesson 5.1.4
8	Lesson 5.1.5
9 and 10	Lesson 5.2.1
11 and 12	Lesson 5.2.2
13	Lesson 5.2.3

Select questions to assign according to the time available.

## Answers

1. a) *Sample response:*

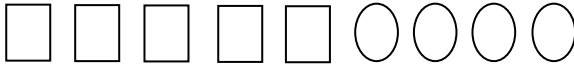

b) 5 : 9, 4 : 9, 4 : 5

2. *Sample response:*

4 : 8 (4 books to 8 pencils),  
1 : 4 (1 school bag to 4 books),  
1 : 8 (1 water bottle to 8 pencils)

3. a) 3      b) 36      c) 30      d) 105

4. 5 spoonfuls

5. B; *Sample response:*

In mixture B, there is more than 1 g of sugar in each 50 mL of water, while mixture A has exactly 1 g of sugar per 50 mL.

6. Group B; *Sample response:*

If there are 6 students in a group of 20, that is equivalent to 3 in a group of 10, or 9 in a group of 30. 9 in a group of 30 is more than 8 in a group of 30.

7. *Sample response:*

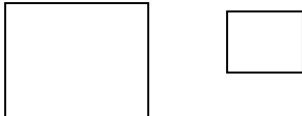

I made each side half as long in the smaller rectangle.

8. 5 chocolate bars for Nu 200

*Sample response:*

5 bars for Nu 200 is equivalent to 1 bar for Nu 40. This is better than 3 bars for Nu 144 (1 bar for Nu 48) or 6 bars for Nu 300 (1 bar for Nu 50).

9. a) *Sample response:*

12% grey and 26% black

b) 62%

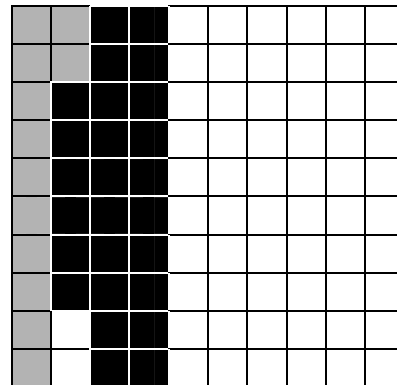

10. C

11. a) 0.15 and  $\frac{15}{100}$

b) 48% and  $\frac{48}{100}$

c) 0.6 and 60%

12.

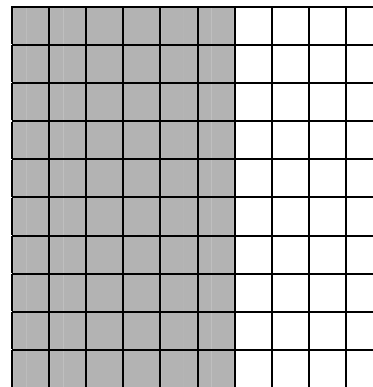

13. Part c),  $\frac{3}{5}$ ;  $60\% > 48\% > 15\%$

## UNIT 5 Performance Task — Fitness Training

Sonam and Tandin are planning to run a race. They are training for the race by walking and running.

**A.** Each day, Sonam trains for 1 h:

- she walks 10 min,
- she runs 20 min,
- she walks another 10 min,
- she runs another 15 min, and then
- she walks the last 5 min.

**i)** Use as many ratios as you can to describe how Sonam spends her training time. For each ratio, tell what each term represents and tell if the ratio is a part-to-part ratio or part-to-whole ratio.

**ii)** Write an equivalent ratio for each ratio in **part i)**.

**iii)** Write Sonam's walking time as a proportion of her training time.

Use a fraction, a decimal, and a percent. Write another fraction, decimal, and percent to show her running time.

**B.** Tandin trains for 90 min each day:

- he walks for 15 min and
- he runs the rest of the time.

Write Tandin's walking time as a proportion of his training time.

Use a fraction, a decimal, and a percent. Write another fraction, decimal, and percent to show his running time.

**C.** Who runs a greater proportion of the training time? How do you know?

**D. i)** Sonam draws the path she follows on a map. The scale ratio of the map is 1 : 160 000 (which means 1 cm on the map is actually 160 000 cm). Her path is actually 8 km long. How many centimetres long is her path on the map? Show your work.

**ii)** Tandin draws his path on a different map. His map has a scale ratio of 3 : 500 000 (which means 3 cm on the map is really 500,000 cm). His path on the map is 7.2 cm long. How long is his real path? Show your work.

**E.** Which information presented above could be described as a rate? How do you know?

## UNIT 5 Performance Task

Curriculum Outcomes Assessed	Pacing	Materials
<b>6-A4 Ratio:</b> part to part, part to whole <b>6-A5 Equivalent Ratios:</b> using models and symbols <b>6-A7 Rates:</b> relating to ratio <b>6-A8 Percent:</b> developing benchmarks and number sense <b>6-C5 Equivalent Ratios:</b> change in one term affects the other term	1 h	None

### How to Use This Performance Task

- You might use this task as a rich problem to assess student understanding of a number of outcomes in this unit. It could replace or supplement the unit test. It could also be used as enrichment material for some students.
- You can assess performance on the task using the rubric on the next page.

### Sample Solution

<p><b>A. i)</b> 10 : 5 to compare the first part of the walk to the last part, part-to-part ratio;            25 : 35 to compare walking time with running time, part-to-part ratio;            20 : 15 to compare the two running times, part-to-part ratio;            25 : 60 to compare the walking time to the total training time, part-to-whole ratio;            35 : 60 to compare the running time with the total training time, part-to-whole ratio.</p> <p><b>ii)</b> 10 : 5 is equivalent to 20 : 10;            25 : 35 is equivalent to 50 : 70;            20 : 15 is equivalent to 4 : 3;            25 : 60 is equivalent to 5 : 12; and            35 : 60 is equivalent to 70 : 120.</p> <p><b>iii)</b> Walking time: <math>\frac{25}{60}</math>, about 0.42, and about 42%.            Running time: <math>\frac{35}{60}</math>, about 0.58, and about 58%.</p>	<p><b>B.</b> Walking time: <math>\frac{15}{90}</math>, about 0.17, and about 17%.            Running time: <math>\frac{75}{90}</math>, about 0.83, and about 83%.</p> <p><b>C.</b> Tandin; 83% &gt; 58%</p> <p><b>D. i)</b> 5 cm;            1 cm to 160 000 cm = 1 cm to 1600 m = 1 cm to 1.6 km  <math>8 \div 1.6</math> is 5.  <b>ii)</b> 12 km;            3 cm to 500 000 cm = 3 cm to 5 km  <math>7.2 \div 3 = 2.4</math>; <math>2.4 \times 5 = 12</math></p> <p><b>E. Sample response:</b>            You could describe the walking and running speeds as rates because each compares distance to time, which have different units.</p>
--	---

## UNIT 4 Performance Task Assessment Rubric

<i>The student</i>	Level 4	Level 3	Level 2	Level 1
<b>Represents comparisons with ratios, rates and percents</b>	Creatively represents situations with a wide variety of ratios; easily and accurately represents situations with percents and rates	Represents situations with a number of different ratios; accurately represents situations with percents and rates	Correctly represents situations with some ratios, percents, and rates	Has difficulty representing situations with ratios, percents, and/or rates
<b>Calculates and compares equivalent ratios, rates, fractions, decimals, or percents</b>	Efficiently and accurately calculates equivalent ratios, fractions, and decimals, compares ratios and percents, and solves ratio problems	Correctly calculates equivalent ratios, fractions, and decimals, compares ratios and percents, and solves ratio problems	Correctly calculates some equivalent ratios, fractions, and decimals, and compares ratios and percents	Has difficulty naming equivalent ratios, fractions, and percents, and has difficulty solving problems involving ratios

# UNIT 5 Blackline Masters

## BLM 1 Getting Started Squares

**BLM 2 Ratio Match Game Cards**

2 : 4	0.75	16%	0.33	0.40	10%
1 : 10	0.23	80%	$\frac{2}{5}$	2 : 3	75%
$\frac{4}{6}$	$\frac{8}{10}$	50%	4 : 6	40%	54%
75 : 100	0.54	23%	$\frac{4}{5}$	0.16	$\frac{2}{3}$
0.1	33%	2 : 5	$\frac{1}{10}$	$\frac{3}{4}$	0.80



# UNIT 6 NUMBER RELATIONSHIPS

## UNIT 6 PLANNING CHART

	Outcomes or Purpose	Suggested Pacing	Materials	Suggested Assessment
Getting Started SB p. 155 TG p. 217	Review prerequisite concepts, skills, and terminology and pre-assessment	1 h	None	All questions
<b>Chapter 1 Large Whole Numbers</b>				
6.1.1 EXPLORE: Solving Problems With Large Numbers (Optional) SB p. 157 TG p. 219	<b>6-A9 Large Numbers: reading and writing</b> <ul style="list-style-type: none"> <li>• read and write large numbers in words (e.g., three hundred forty-five million)</li> </ul> <b>6-B2 Estimation Strategies for Multiplication and Division: whole numbers and decimals</b> <ul style="list-style-type: none"> <li>• apply estimation strategies: rounding, front-end</li> </ul>	1 h	<ul style="list-style-type: none"> <li>• Ruler or metre stick</li> <li>• Cup measure and some rice</li> <li>• Small capacity measure</li> <li>• Nu 1 coin</li> </ul>	Observe and Assess questions
6.1.2 Place Value with Large Whole Numbers SB p. 159 TG p. 221	<b>6-A9 Large Numbers: reading and writing</b> <ul style="list-style-type: none"> <li>• read and write large numbers in words (e.g., three hundred forty-five million)</li> <li>• write large numbers in terms of different units (e.g., 13,200,000 as 13,200 thousand or 13.2 million)</li> <li>• write the expanded form of a number (e.g., 3402 as <math>3 \times 1000 + 4 \times 100 + 2</math>)</li> </ul> <b>6-A10 Place Value: understanding place value patterns</b> <ul style="list-style-type: none"> <li>• understand that the place value system follows a pattern: each place has a value that is 10 times as much as the place to its right and each place has a value that is <math>\frac{1}{10}</math> as much as the place to its left</li> <li>• understand that digits are grouped in 3s for the purpose of interpreting and reading numbers</li> </ul>	1 h	<ul style="list-style-type: none"> <li>• Place Value Charts II (BLM) (optional)</li> </ul>	Q2, 3, 5
6.1.3 Renaming Numbers SB p. 162 TG p. 224	<b>6-A10 Place Value: understanding place value patterns</b> <ul style="list-style-type: none"> <li>• understand that the place value system follows a pattern: each place has a value that is 10 times as much as the place to its right and each place has a value that is <math>\frac{1}{10}</math> as much as the place to its left</li> <li>• understand that digits are grouped in 3s for the purpose of interpreting and reading numbers</li> </ul>	1 h	<ul style="list-style-type: none"> <li>• Place Value Charts II (BLM) (optional)</li> </ul>	Q3, 5, 6

## UNIT 6 PLANNING CHART [Continued]

	Outcomes or Purpose	Suggested Pacing	Materials	Suggested Assessment
<b>Chapter 2 Decimals and Integers</b>				
<b>6.2.1</b> Place Value with Decimals <b>SB p. 166</b> <b>TG p. 227</b>	<b>6-A10 Place Value: understanding place value patterns</b> <ul style="list-style-type: none"> <li>understand that the place value system follows a pattern: each place has a value that is 10 times as much as the place to its right and each place has a value that is <math>\frac{1}{10}</math> as much as the place to its left</li> </ul>	1 h	<ul style="list-style-type: none"> <li>Place Value Charts III (BLM) (optional)</li> </ul>	Q2, 4, 5
<b>6.2.2</b> Comparing and Ordering Decimals <b>SB p. 168</b> <b>TG p. 229</b>	<b>6-A10 Place Value: understanding place value patterns</b> <ul style="list-style-type: none"> <li>understand that the place value system follows a pattern: each place has a value that is 10 times as much as the place to its right and each place has a value that is <math>\frac{1}{10}</math> as much as the place to its left</li> </ul>	1 h	<ul style="list-style-type: none"> <li>Place Value Charts III (BLM) (optional)</li> </ul>	Q1, 4, 5
<b>6.2.3</b> Introducing Integers <b>SB p. 170</b> <b>TG p. 231</b>	<b>6-A11 Integers: negative and positive</b> <ul style="list-style-type: none"> <li>develop meaning of integers using models and symbols</li> <li>explore negative integers in context (e.g., temperature, money, sea level heights)</li> <li>understand that each negative integer is the opposite of a positive integer with respect to 0 on a number line</li> <li>understand that 0 is neither positive or negative</li> <li>compare integers</li> </ul>	1 h	None	Q1, 5, 6
<b>Chapter 3 Number Theory</b>				
<b>6.3.1</b> Prime Numbers <b>SB p. 173</b> <b>TG p. 233</b>	<b>6-A12 Prime Numbers: distinguish from composites</b> <ul style="list-style-type: none"> <li>understand that a prime number is a number that has exactly two factors</li> <li>model prime numbers as dimensions (other than 1) of unique rectangles with particular whole number areas</li> <li>understand that 1 is not a prime number</li> </ul>	1 h	<ul style="list-style-type: none"> <li>Grid paper or Small Grid Paper (BLM) (optional)</li> </ul>	Q1, 6, 7
CONNECTIONS: The Sieve of Eratosthenes (Optional) <b>SB p. 175</b> <b>TG p. 235</b>	Make a connection between displaying numbers in a 100 chart and prime numbers	20 min	<ul style="list-style-type: none"> <li>100 Charts (BLM)</li> </ul>	N/A
<b>6.3.2 EXPLORE:</b> Square and Triangular Numbers (Essential) <b>SB p. 177</b> <b>TG p. 236</b>	<b>6-C6 Square and Triangular Numbers: represent pictorially and symbolically</b> <ul style="list-style-type: none"> <li>represent square and triangular numbers pictorially and symbolically to show both geometric and numerical patterns</li> <li>understand that square numbers may be represented in square arrays and are the products of numbers multiplied by themselves</li> <li>understand that a triangular number is half the number in an array with dimensions that are one unit apart</li> </ul>	40 min	<ul style="list-style-type: none"> <li>Grid paper or Small Grid Paper (BLM) (optional)</li> </ul>	Observe and Assess questions

CONNECTIONS: Triangular Numbers as Products (Optional) <b>SB p. 178</b> <b>TG p. 237</b>	Make a connection between factoring and triangular numbers	15 min	None	N/A
<b>6.3.3 EXPLORE:</b> Factors (Essential) <b>SB p. 179</b> <b>TG p. 238</b>	<b>6-A13 Factors: whole numbers</b> <ul style="list-style-type: none"> <li>• conclude that a number is a multiple of any of its factors</li> <li>• find factors by dividing systematically</li> <li>• understand, through investigation, that the greatest factor is always the number itself and the least factor is always 1</li> <li>• understand, through investigation, that the second greatest factor is always <math>\frac{1}{2}</math> the number or less</li> </ul>	40 min	None	Observe and Assess questions
GAME: Down to Prime (Optional) <b>SB p. 176</b> <b>TG p. 239</b>	Practise factoring and recognition of prime numbers in a game situation	25 min	• Dice	N/A
<b>6.3.4 Common Factors</b> <b>SB p. 180</b> <b>TG p. 240</b>	<b>6-A14 Common Factors: whole numbers</b> <ul style="list-style-type: none"> <li>• find factors in a systematic way</li> <li>• understand that 1 is always a common factor of any two numbers</li> <li>• find common factors of two or three numbers</li> </ul>	1 h	None	Q1, 2, 6
UNIT 6 Revision <b>SB p. 183</b> <b>TG p. 243</b>	Review the concepts and skills in the unit	2 h	• Place Value Charts II and III (BLM) (optional)	All questions
UNIT 6 Test <b>TG p. 245</b>	Assess the concepts and skills in the unit	1 h	• Place Value Charts II and III (BLM) (optional)	All questions
UNIT 6 Performance Task <b>TG p. 247</b>	Assess concepts and skills in the unit	1 h	None	Rubric provided
UNIT 6 Blackline Masters <b>TG p. 249</b>	BLM 1 Place Value Charts II (the one billions place to the ones place in periods) BLM 2 Place Value Charts III (the tens place to the ten thousandths place) BLM 3 100 Charts Small Grid Paper on <b>page 38</b> in UNIT 1			

## Math Background

- An understanding of number is fundamental to success in mathematics. This unit deals with many different number topics, including large whole numbers, decimal ten thousandths, integers, prime, square, and triangular numbers, and factoring.
- As students proceed through this unit they will use a variety of mathematical processes, including problem solving, communication, reasoning, representation, visualization, and making connections.

For example:

- Students use problem solving throughout **lesson 6.1.1**, where they solve Fermi problems, in **question 7** in **lesson 6.2.1**, where they use decimal information about Thimphu to figure out its population, in **question 5** in **lesson 6.3.1**, where they look for pairs of prime numbers that meet a given condition, and in **question 6** in **lesson 6.3.4**, where they solve a problem by using the concept of common factors.
- Students use communication in **question 8** in **lesson 6.2.1**, where they explain what place should be to the right of the ten thousandths place, in **question 8** in **lesson 6.2.2**, where they discuss how comparing decimals is like comparing whole numbers, in **question 7** in **lesson 6.3.1**, where they describe how to test a number to see if it is prime, and in **question 7** in **lesson 6.3.4**, where they describe properties of common factors.
- Students use reasoning in **question 4** in **lesson 6.1.2**, where they consider how to write numbers using units other than 1, in **question 4** in **lesson 6.2.1**, where they relate the renaming of decimals to equivalence, in **question 6** in **lesson 6.2.2**, where they reason about possible missing digits to make an inequality true, in **question 4** in **lesson 6.3.1**, where they reason about how close together prime numbers can be, and in **question 4** in **lesson 6.3.4**, where they see how the common factors of two numbers can be related.

- Students consider representation in **question 8** in **lesson 6.1.3**, where they consider why it might be better to use an alternate unit to represent a large number, in the **Connections** after **lesson 6.2.3**, where they write triangular numbers as products, and in **lesson 6.3.3**, where they represent numbers as products in more than one way.
- Students use visualization in **question 7** in **lesson 6.2.3**, where they use a number line to visualize integer relationships, throughout **lesson 6.3.2**, where they explore square and triangular numbers using visual models, and in **lesson 6.3.4**, where they use a factor rainbow to see how factors come in pairs.
- Students make connections in **question 6** in **lesson 6.1.3**, where they relate large numbers to a real-world context, in **question 7** in **lesson 6.2.2**, where they relate the areas of countries based on decimal relationships that describe the areas, and in **question 4** in **lesson 6.2.3**, where they create contexts for integers.

## Rationale for Teaching Approach

- This unit is divided into three chapters:
  - Chapter 1** focuses on large whole numbers.
  - Chapter 2** focuses on decimals and integers.
  - Chapter 3** focuses on number theory, including the concepts of prime, square, and triangular numbers, and factors and common factors.
- There are three explorations:
  - The first **Explore** lesson allows students to explore Fermi problems. Students are required to use estimates and calculations to solve real-world problems.
  - The second **Explore** lesson allows students to use models to explore square and triangular numbers.
  - The last **Explore** lesson has students examine how the various factors of a number are related.
- There are two **Connections**. The first shows a historical connection — how Eratosthenes found the prime numbers. The second shows an interesting numerical property of triangular numbers.
- The **Game** lets students practise factoring.

## Getting Started

Curriculum Outcomes	Outcome relevance
<ul style="list-style-type: none"> <li>5 Factors: of whole numbers</li> <li>5 Place Value: whole numbers to 7 digits</li> <li>5 Comparing: order 7-digit whole numbers</li> <li>5 Thousandths: model and record</li> </ul>	Reviewing what students know about place value and factors will support their work in this unit

Pacing	Materials	Prerequisites
1 h	None	<ul style="list-style-type: none"> <li>• familiarity with whole number place value to seven digits and decimals to thousandths, including naming numbers by reading, writing in symbols, and writing in words</li> <li>• comparing whole numbers</li> <li>• renaming whole numbers</li> </ul>

### Main Points to be Raised

#### *Use What You Know*

- One whole number is greater than another whole number with the same number of digits if the digit farthest to the left is greater.
- You can use place value concepts to create numbers that are a certain number of millions or thousands apart; you do not need to subtract.

#### *Skills You Will Need*

- By counting the number of digits in a whole number, you can tell which digit is in which place.
- You can rename 1 million as 1000 thousands, as 10 hundred thousands, or as 100 ten thousands. You can also use a decimal to rename a large whole number if you change the units.  
For example, 4.2 million is 4 million + 2 hundred thousand, or 4,200,000.
- You can write a number in expanded form by writing how many of each place value there are.
- You can read a whole number by focusing on periods of three digits.
- The three digits to the right of the decimal point are tenths, hundredths, and thousandths.
- You can rename tenths as hundred thousandths or as ten hundredths. You can rename hundredths as ten thousandths.
- A multiple of a number is the result of multiplying the number by another whole number.
- A factor of a number is another number that divides evenly into the number with no remainder.

### Use What You Know — Introducing the Unit

- To complete this activity, students may choose to copy the place value chart, but they are not required to do so.
- Before assigning the activity, help students recall what a 7-digit number means. Ask students to read the number 3,100,204 and describe what each digit represents. Then ask them to write a number that is about 100,000 greater than 2,123,456.
- Students can work in pairs to complete the activity.

While you observe students at work, you might ask questions such as the following:

- *Why did you put the 9 there?* (I wanted as many millions as possible to make the number greater.)
- *Why did you put those digits to the left?* (I wanted a low number, so I wanted fewer millions and hundred thousands, and more tens and ones.)
- *How do you know they are about 6 million apart?* (The millions digits are 9 and 3, which is 6 million apart, and the only other digits that are different are really small parts of the number — they are only tens.)
- *How do you know that this number is the second highest number?* (I kept the greater digits on the left and exchanged the tens and ones. Now I had fewer tens and more ones, so it was less, but not much less.)



## Chapter 1 Large Whole Numbers

### 6.1.1 EXPLORE: Solving Problems with Large Numbers

Curriculum Outcomes	Lesson relevance
<b>6-A9 Large Numbers: reading and writing</b> <ul style="list-style-type: none"><li>• read and write large numbers in words (e.g., three hundred forty-five million)</li></ul> <b>6-B2 Estimation Strategies for Multiplication and Division: whole numbers and decimals</b> <ul style="list-style-type: none"><li>• apply estimation strategies: rounding, front-end</li></ul>	This optional exploration allows students to solve interesting problems involving estimation with large numbers.

Pacing	Materials	Prerequisites
1 h	<ul style="list-style-type: none"><li>• Ruler or metre stick</li><li>• Cup measure and some rice</li><li>• Small capacity measure</li><li>• Nu 1 coin</li></ul>	<ul style="list-style-type: none"><li>• calculating with whole numbers</li></ul>

#### Exploration

- Read through the exposition on **page 157** of the student text, which provides the background for Fermi problems. Work through the example with the students. Make sure they understand that they must make and list their assumptions before they can solve the problem.
- Encourage students to work in pairs. You may suggest that they choose only two of the problems to work on. Make sure that they check their work to see if the answers make sense. You may have to provide students with information that they can base their calculations on; for example, there are about 4.5 cups of rice in 1 kg and the number of people in Bhutan is about 650,000.

While you observe students at work, you might ask questions such as the following:

- *What assumptions are you making?* (That I could keep walking as fast as I walked when I counted my steps.)
- *Why are those assumptions reasonable?* (I counted the number of grains of rice in 1 spoonful 4 times and used the average. I also tested two times to see how many spoonfuls make 1 cup.)
- *Why did you use those calculations?* (I had to multiply the number of students by the number of pencils I think each student would use.)
- *How do you know your calculations are reasonable?* (I checked by multiplying and adding a different way.)
- *Do you think your answer is too high or too low? Why?* (I think I estimated the number of coins too high since I rounded up both for the length and for the width of the field.)

#### Observe and Assess

As students work, notice the following:

- Can students make reasonable assumptions?
- Do students realize what assumptions they are making?
- Do students choose appropriate calculations for each situation?
- Do students explain their calculations appropriately?
- Do students look back and check the reasonableness of their work?

#### Share and Reflect

After students have had sufficient time to work through the exploration, discuss questions such as these:

- *How do you know your answer is not exact?*
- *How far off do you think it might be? Why?*
- *Can you create another Fermi problem?*

## Answers

<p><b>A. Sample response:</b> About 4000 km</p> <p><i>Assumptions</i></p> <ul style="list-style-type: none"><li>• I can multiply my step size for a short distance to find the number of steps for a longer distance.</li><li>• I would be able to keep walking 200 cm every 5 steps for 4000 km.</li><li>• I am answering based on normal walking steps.</li></ul> <p><i>Solution</i></p> <p>With 5 steps, I walked about 200 cm. So, with 10 steps I would walk about 400 cm or 4 m. If 10 steps cover 4 m, then 10 million steps cover 4 million m. Every 1000 m are 1 km, so 4 million m or 4000 thousand m are 4000 km.</p> <p><b>B. Sample response:</b> 36,000 grains</p> <p><i>Assumptions</i></p> <ul style="list-style-type: none"><li>• There are about 16 tablespoons in 1 cup (I measured).</li><li>• 1 kg of rice is about 4.5 cups of rice (I measured).</li><li>• I based my answer on dry uncooked rice.</li><li>• My estimate is for red rice. Other types of rice will be different.</li></ul> <p><i>Solution</i></p> <p>I counted the number of grains in 1 tablespoon. It was about 500. There are about 16 tablespoons in 1 cup, so a cup would contain about <math>16 \times 500 = 8000</math> grains. 4.5 cups are 1 kg, so I multiplied <math>4 \times 8000</math> grains and added 4000 grains for the half. I got 36,000 grains.</p> <p><b>C. Sample response:</b> Between 6 million and 7 million coins</p> <p><i>Assumptions</i></p> <ul style="list-style-type: none"><li>• The football field measures 100 m <math>\times</math> 60 m.</li><li>• A ngultrum coin measures about 3 cm across.</li><li>• The coins touch each other but do not overlap.</li><li>• The coins are lined up in rows and columns.</li></ul>	<p><i>Solution</i></p> <p>100 m = 10,000 cm <math>10,000 \div 3</math> is about 3333, so there would be about 3333 rows. 60 m = 6000 cm <math>6000 \div 3 = 2000</math>, so there would be about 2000 columns. <math>2000 \times 3333 = 6,666,000</math> Between 6 million and 7 million coins would cover the field.</p> <p><b>D. Sample response:</b> 1,640,000 pencils</p> <p><i>Assumptions</i></p> <ul style="list-style-type: none"><li>• There are about 100,000 students from Class PP to Class VI in Bhutan.</li></ul> <p>I think that because there are about 650,000 people in Bhutan and I think about <math>\frac{1}{3}</math> of those are children and about half of these children are in Classes PP to VI.</p> <ul style="list-style-type: none"><li>• There are about 60,000 students in Classes VII to X. I think that because there are only 4 classes in this range instead of 6, so that would be about <math>\frac{4}{6}</math> of 100,000 or 67,000, but some students do not continue to higher classes, so I will use a lower number like 60,000.</li><li>• There are about 4000 students in public schools in Classes XI and XII because many students do not continue from Class X to Class XI and XII.</li><li>• I use about 10 pencils a year, so I will assume each student uses that same number of pencils.</li></ul> <p><i>Solution</i></p> <p><math>100,000 + 60,000 + 4000 = 164,000</math> students altogether. If each student uses 10 pencils, all the students in Bhutan would use 1,640,000 pencils.</p>
--	---

## Supporting Students

### *Struggling students*

- Some students will have difficulty describing their assumptions. You may wish to give them some suggestions for assumptions they could use.

### *Enrichment*

- Students may wish to investigate other Fermi-type problems such as these:
  - Estimate the total number of hairs on your head.
  - Estimate the amount of rice produced in Bhutan each year.
  - Estimate how many pencils it would take to draw a straight line along the equator.
  - Estimate the weight of solid garbage thrown away by Bhutanese families every year.

If there is a possibility of using the Internet, you can find more problems at <http://schools.hpedsb.on.ca/smood/fermi.htm> and <http://www.physics.umd.edu/perg/fermi/fermi.htm>.



## 6.1.2 Place Value with Large Whole Numbers

Curriculum Outcomes	Outcome relevance
<p><b>6-A9 Large Numbers: reading and writing</b></p> <ul style="list-style-type: none"> <li>• read and write large numbers in words (e.g., three hundred forty-five million)</li> <li>• write large numbers in terms of different units (e.g., 13,200,000 as 13,200 thousand or 13.2 million)</li> <li>• write the expanded form of a number (e.g., 3402 as <math>3 \times 1000 + 4 \times 100 + 2</math>)</li> </ul> <p><b>6-A10 Place Value: understanding place value patterns</b></p> <ul style="list-style-type: none"> <li>• understand that the place value system follows a pattern: each place has a value that is 10 times as much as the place to its right and each place has a value that is <math>\frac{1}{10}</math> as much as the place to its left</li> <li>• understand that digits are grouped in 3s for the purpose of interpreting and reading numbers</li> </ul>	<p>It is important for students to be able to read and write large numbers to describe many real-world situations.</p>

Pacing	Materials	Prerequisites
1 h	<ul style="list-style-type: none"> <li>• Place Value Charts II (BLM) (optional)</li> </ul>	<ul style="list-style-type: none"> <li>• familiarity with place value concepts to the millions, including reading and writing numbers in standard and expanded notation</li> </ul>

### Main Points to be Raised

- It is easier to interpret and understand numbers if you read them in groups of three digits called periods.
- The period to the left of the thousands period is the millions period. It includes hundred millions, ten millions, and one millions.
- The billions period is to the left of the millions period. One billion is 1000 million.
- You can write a large number in standard or expanded form, just as you do with a smaller number. Standard form uses only numerals, while expanded form involves writing numbers in terms of their place value.  
For example:  
210,000,000 in standard form is  $2 \times 100,000,000 + 1 \times 10,000,000$ .  
210,000,000 in expanded form is 2 hundred millions + 1 ten million.
- You compare large numbers just like you compare smaller numbers, always starting at the left.

### Try This — Introducing the Lesson

- A.** Allow students to try this alone or with a partner. While you observe students at work, you might ask questions such as the following:
- *Why does 86,000 seconds make sense?* (There are 60 seconds in a minute, so there are  $60 \times 60 = 3600$  seconds in an hour. Since there are 24 hours in a day, there are  $3600 \times 24$  seconds in a day.  $3600 \times 24 = 3600 \times 25 - 3600$ . That is  $900 \times 100 - 3600$ , which is about  $90,000 - 4000 = 86,000$ .)
  - *How did you estimate the number of seconds in a week?* (To multiply  $7 \times 86,000$ , I used  $7 \times 90,000$  and reduced it a little, to 610,000.)
  - *How could you estimate the number of seconds in a month?* (I could multiply  $30 \times 90,000$  and reduce it a bit to get 2,600,000, or I could multiply the number of seconds in a week by 4 and add a bit, to get 2,500,000.)
  - *How did you estimate the number of seconds in a year?* (I multiplied the number of seconds in a month by 12, so I used  $2,500,000 \times 12 = 10,000,000 \times 3 = 30,000,000$  seconds.)

## The Exposition — Presenting the Main Ideas

Note that this mathematics text assumes 1,000,000,000 is "one billion"; in some places, 1,000,000,000,000 is "one billion".

- Ask students to open their texts to **page 159**. Point out the place value chart in the middle and show them how to read the number 123,010,423 on the chart. Bring their attention to the fact that each group of three digits is called a period, and each period includes a hundreds column, a tens column, and a ones column.
- Next, have students look at the chart near the bottom of the page, where the billions period is introduced. Help them see why 1 billion is 1000 million (since it is 10 hundred million). If students ask, indicate that there are also ten billion and hundred billion columns, but that these are not used in Class VI.
- Remind students about standard and expanded forms by having them write the number 1,040,000 in expanded form (as either 1 million + 4 ten thousands or as  $1,000,000 + 4 \times 10,000$ ). Then explain that the same process is used for numbers in the ten millions, hundred millions, and billions. Have them look at the example in the text.
- Finally, ask students to tell how they would compare 3,020,010,000 and 3,201,010,000. Then ask how they would compare 3,020,010,000 and 423,020,300. See what they suggest and, if necessary, help them see why  $3,201,010,000 > 3,020,010,000$  since there are the same number of billions (3), but more hundred millions, but that  $3,020,010,000 > 423,020,300$  since there are billions in the first number but not in the second number.

## Revisiting the Try This

**B.** Students have the opportunity to practise using expanded form with the numbers from **part A**.

## Using the Examples

- Ask students to read through the three examples and then raise any questions they might have.

## Practising and Applying

### Teaching points and tips

**Q 2:** You may wish to remind students that one way to write the number in expanded form is to use the words that describe the place value columns. Another way is to use the product of each digit and its place value amount.

**Q 3:** Encourage students to refer to **example 3** to help with this question.

**Q 4:** There is no example exactly like this, but students can use the idea of **example 3** to help them.

For example, they can write 1,000,000 on the place value chart and then trade to the right to see how the number could be shown as 1000 of something.

(1 million = 10 hundred thousands =  
100 ten thousands = 10000 thousands).

**Q 5:** You may suggest that students write the first number in standard form to help them order the three numbers. Or, they may simply estimate — the first number is about 3 billion, the second number is 8 or 9 million and the third number is more than 4 billion.

**Q 7:** This question is unlike questions students might have answered before. Some students might choose to copy the words onto slips of paper and rearrange the slips of paper. Because one term is fifty, the digit 5 must appear in the tens column of one of the periods.

**Q 8:** You may wish to handle this question in a group discussion.

### Common errors

- Some students confuse millions and billions for numbers with one, but not both, groups.

For example, they might write sixty-six billion, four hundred thousand, five as 66,400,005. You might suggest that they use a place value chart.

### Suggested assessment questions from Practising and Applying

<b>Question 2</b>	to see if students can write a number in expanded form
<b>Question 3</b>	to see if students can write a number in standard form
<b>Question 5</b>	to see if students can order a group of numbers

## Answers

<b>A. i)</b> About 600 thousand seconds <b>ii)</b> About 2500 thousand seconds <b>iii)</b> About 30,000 thousand seconds	<b>B. i)</b> 6 hundred thousands; $6 \times 100,000$ <b>ii)</b> 2 millions + 5 hundred thousands; $2 \times 1,000,000 + 5 \times 100,000$ <b>iii)</b> 3 ten millions; $3 \times 10,000,000$
<b>1. a)</b> 302,054,000 <b>b)</b> 2,053,000,089 <b>c)</b> 6,000,400,005  <b>2. a)</b> 3 billions + 4 ten millions + 5 millions + 1 hundred thousand; $3 \times 1,000,000,000 + 4 \times 10,000,000 + 5 \times 1,000,000 + 1 \times 100,000$ <b>b)</b> 1 billion + 2 hundred millions + 3 millions + 5 hundred thousands; $1 \times 1,000,000,000 + 2 \times 100,000,000 + 3 \times 1,000,000 + 5 \times 100,000$  <b>3. a)</b> 1,000,000,000 <b>b)</b> 100,000,000 <b>c)</b> 1,000,000,000  <b>4. a)</b> Thousand <b>b)</b> Hundred thousand	<b>5.</b> 8,840,230; 3.2 billion; 4,235,100,023  <b>6.</b> 21,342,899; [ <i>Sample response:</i> • Decide which place value is farthest left: Both numbers start with the same place value. • Then start comparing digits from the left: Both numbers have 2 ten millions and 1 million, but the second number has more hundred thousands, so it is greater.]  <b>7. Sample response:</b> 6,200,054; 2,600,054; 56,200,004; 52,600,004; 56,400,002  <b>[8. Sample response:</b> Each place value is 10 times as much as the place value to its right.]

## Supporting Students

### *Struggling students*

- Some students may have difficulty with **questions 3 and 4**, which are not quite as straightforward as **questions 1 and 2**. Encourage students to use a place value chart.
- You might choose not to assign **question 7** to struggling students, or you might model one or two examples for them and ask them to come up with one or two other examples.

### *Enrichment*

- Students might create phrases as in **question 7** using other words and numbers. They could exchange their phrases with other students to see who can create more expressions with the given words and numbers.

## 6.1.3 Renaming Numbers

Curriculum Outcomes	Outcome relevance
<p><b>6-A10 Place Value: understanding place value patterns</b></p> <ul style="list-style-type: none"> <li>understand that the place value system follows a pattern: each place has a value that is 10 times as much as the place to its right and each place has a value that is <math>\frac{1}{10}</math> as much as the place to its left</li> <li>understand that digits are grouped in 3s for the purpose of interpreting and reading numbers</li> </ul>	When they understand the patterns in the place value system, students can interpret and compare large numbers with more flexibility.

Pacing	Materials	Prerequisites
1 h	• Place Value Charts II (BLM) (optional)	• familiarity with place value concepts to the millions, including renaming numbers to the millions

### Main Points to be Raised

- You can use a place value chart to help you rename a number. You trade 10 of one value for only 1 of the value to its left.
- To compare two large numbers, it is sometimes useful to rename one of the numbers.

### Try This — Introducing the Lesson

A. Allow students to try this alone or with a partner. While you observe students at work, you might ask questions such as the following:

- How many digits does 62 million have? Why?* (8 digits; 9,999,999 is the greatest 7-digit number and it is less than 10 million.)
- Why are there two parts to the expanded notation for 62 million?* (There are two non-zero digits.)
- Why do you think the population is an estimate?* (The population of a country changes every hour as people are born, people die, and people move from one country to another.)

### The Exposition — Presenting the Main Ideas

- Lead students through the exposition.

Draw a place value chart on the board. In the case of 3,200,000, show how it is 3.2 million by drawing an arrow just to the right of the millions place.

Millions			Thousands			Ones		
H	T	O	H	T	O	H	T	O
		3	2	0	0	0	0	0

↑

Point out why this makes sense; the number is more than 3 million. 3.2 is more than 3, but not a lot more.

- Show that this is also 320 ten thousand by moving the arrow just to the right of the ten thousands place. Students can see the 320 to the left of the arrow. Make sure students understand that each of the 2 hundred thousands is 20 ten thousands and the 3 million is 30 hundred thousands or 300 ten thousands, so the total of 320 ten thousands makes sense.
- Point out how these same ideas are modelled on **page 163** of the student text, where 1,200,000,000 is renamed.

### Revisiting the Try This

B. Students have an opportunity to think about why numbers are named the way they are.

## Using the Examples

- Present the questions in the three examples to the students. They can try them and compare their responses to the solutions in the text.

## Practising and Applying

### Teaching points and tips

**Q 1:** Encourage students to use a place value chart to record the digits of the numbers.

**Q 2:** Some students may wish to write some basic conversions to check their answers.

For example, if they realize that

1 billion = 1000 million and

1 hundred million = 1000 hundred thousand,  
they can see if their answers make sense.

**Q 3:** Students might rename all the numbers as millions or ten millions to answer the question.

**Q 4:** To get students started, you might have them fill in the blank on the right with any place value they wish and then figure out the corresponding blank on the left.

**Q 5:** This question is designed to reinforce the idea that it is the number of non-zero digits in a number that determines the number of terms in the expanded form.

**Q 7:** Students might rename 0.38 billion as 380 million to help them answer this question.

**Q 8:** Students can consider ease of reading, writing, or interpreting the number.

### Common errors

- Some students only use the place values to the left of the place value they need to consider, and forget to include the place value itself.

For example, to write 3,200,000,000 as millions, they might write 320 rather than 3200. Encourage them to use the place value chart and perform the trades until there is nothing to the left of the column in question.

Billions	Millions			Thousands			Ones		
0	H	T	O	H	T	O	H	T	O
3	2	0	0	0	0	0	0	0	0

↓

Billions	Millions			Thousands			Ones		
0	H	T	O	H	T	O	H	T	O
	3	2	0	0	0	0	0	0	0

↓

Billions	Millions			Thousands			Ones		
0	H	T	O	H	T	O	H	T	O
		3	2	0	0	0	0	0	0

↓

Billions	Millions			Thousands			Ones		
0	H	T	O	H	T	O	H	T	O
			3	2	0	0	0	0	0

### Suggested assessment questions from Practising and Applying

<b>Question 3</b>	to see if students can rename large numbers to compare them
<b>Question 5</b>	to see if students can predict what the expanded form of a number will look like
<b>Question 6</b>	to see if students can rename large numbers in a real-world context

## Answers

<p><b>A. i)</b> 62,000,000; 6 ten millions + 2 millions <b>ii)</b> No; <i>Sample response:</i> It is probably an estimate since the population would keep changing.</p>	<p><b>B. Sample response:</b> Perhaps it is presented that way so that there is no need to count digits to check how big the number is.</p>
<p><b>1. a)</b> 3.45                      <b>b)</b> 3450                      <b>c)</b> 345</p> <p><b>2. a)</b> 4,200,000,000              <b>b)</b> 31,400,000 <b>c)</b> 5,800,000,000              <b>d)</b> 1,230,000</p> <p><b>3.</b> 123 ten million; 3134 million; 3.2 billion; 58 hundred million</p> <p><b>4. Sample response:</b> 31.2 ten million = 312 million 31.2 billion = 312 hundred million 31.2 hundred million = 312 ten million</p>	<p><b>5.</b> Two; 0.34 has two non-zero digits.</p> <p><b>6. a)</b> 32,000 <b>b)</b> 1.412 <b>c)</b> 68,200,000</p> <p><b>7.</b> About 4 million</p> <p><b>[8. Sample response:</b> It takes less space to write it that way and is easier to recognize quickly when you read it.]</p>

## Supporting Students

### *Struggling students*

- If students struggle with billions, change the values in the questions to use only numbers in the millions period.
- Encourage students to use a place value chart to help them with their renaming throughout the exercises.
- For **question 7**, you might suggest that students rename the 0.38 billion rather than trying to rename the 384 million.

### *Enrichment*

- Some students might be ready to consider place values to the left of the billions. They could repeat **question 1** using the number 23,450,000,000 and **question 7** using 0.38 ten billion and 384 ten million.

## Chapter 2 Decimals and Integers

### 6.2.1 Place Value with Decimals

Curriculum Outcomes		Outcome relevance
<b>6-A10 Place Value: understanding place value patterns</b> <ul style="list-style-type: none"><li>understand that the place value system follows a pattern: each place has a value that is 10 times as much as the place to its right and each place has a value that is <math>\frac{1}{10}</math> as much as the place to its left</li></ul>		When they understand the patterns in the place value system, students can better interpret and compare decimals with 3 and 4 decimal places.
Pacing	Materials	Prerequisites
1 h	• Place Value Charts III (BLM) (optional)	• representing and renaming decimal tenths, hundredths, and thousandths

#### Main Points to be Raised

- The place value to the right of the thousandths place is the ten thousandths place.
- You can read a decimal of the form 0.xxxx as “xxxx ten thousandths”.

#### Try This — Introducing the Lesson

A. Allow students to try this alone or with a partner. While you observe students at work, you might ask questions such as the following:

- How do you write 1.1 billion in standard form? (1,100,000,000)
- Why do you still use the 1.1 when you take 0.001 of it? (I needed to change billions to millions; I did not need to change the actual number. That is because it takes 1000 millions to make 1 billion.)
- How else could you have calculated 0.001 of 1.1 billion? (I could have removed the last 3 zeros on the right.)
- How do you know that 1.1 million is less? (There are not even 2 million, but Kolkata has more than 4 million.)

#### The Exposition — Presenting the Main Ideas

- Work through the exposition with students. Introduce the ten thousandths place as the place to the right of the thousandths. It is a mirror image of the ten thousands place, which is to the left of the thousands place.

- Point out that it makes sense that ten thousandths are to the right of thousandths since  $\frac{10}{10,000} = \frac{1}{1000}$

(by dividing numerator and denominator by 10). As with every other place value, ten of a value is equivalent to one of the value to its left.

#### Revisiting the Try This

B. Students might calculate the city’s population by dividing by 10,000 mentally (removing four zeros at the right) or by using place value concepts and moving the digits of 1,100,000,000 four places to the right.

#### Using the Examples

- Present the questions from the example to the students. Ask them to try the questions. They can then compare their work to the two solutions shown in the text.

#### Practising and Applying

##### Teaching points and tips

**Q 3:** To rename the decimals, students can use either a place value chart or equivalent fractions.

For example,  $\frac{1}{10,000} = \frac{0.01}{100}$  since you divide

numerator and denominator by 100. Or, students can use the place value chart and put an arrow on the right beyond the hundredths column.

**Q 4:** Students might think of 0.8000 as 800 thousandths + 0 ten thousandths, or they might think of trading each thousandth for 10 ten thousandths, or they might see what the digits look like on the place value chart.

[Continued]





## 6.2.2 Comparing and Ordering Decimals

Curriculum Outcomes	Outcome relevance
<b>6-A10 Place Value: understanding place value patterns</b> <ul style="list-style-type: none"> <li>understand that the place value system follows a pattern: each place has a value that is 10 times as much as the place to its right and each place has a value that is <math>\frac{1}{10}</math> as much as the place to its left</li> </ul>	When they understand the patterns in the place value system, students have more flexibility in interpreting and comparing decimals with 3 and 4 decimal places.

Pacing	Materials	Prerequisites
1 h	<ul style="list-style-type: none"> <li>Place Value Charts III (BLM) (optional)</li> </ul>	<ul style="list-style-type: none"> <li>familiarity with place value of decimals to the ten thousandths place</li> </ul>

### Main Points to be Raised

- You can compare decimals with different whole number parts by comparing the whole numbers.
- When decimals have the same whole number, you compare the decimal digits starting at the tenths place and then working toward the right.

### Try This — Introducing the Lesson

A. Allow students to try this alone or with a partner. While you observe students at work, you might ask questions such as the following:

- How can you read 0.003?* (Three thousandths)
- How can you read 0.0001?* (One ten thousandth)
- Why do you think that 0.003 is greater even though there are fewer decimal places?* (A day is longer than an hour.)

### The Exposition — Presenting the Main Ideas

Have students read through the exposition on **page 168** of the student text. Allow time for them to ask any questions they might have.

### Revisiting the Try This

B. Encourage students to use place value charts to compare 0.003 and 0.0001.

### Using the Examples

- Present the question from the example. Students can check their work against the solution in the text.

### Practising and Applying

#### Teaching points and tips

**Q 1:** Some students might benefit from using a place value chart.

**Q 4:** The focus of this question is on the explanation, so describing a rule is only the first step.

**Q 5:** Students might rewrite all three numbers as ten thousandths, or they might use a place value chart.

**Q 6:** Some students will replace the blanks with digits to help them explain, whereas others will not need to do so.

**Q 7:** Suggest that students use a diagram to help them answer this question.

For example, they might consider a full thousandths grid as the area of India, one rectangle of the grid as the area of Macau, and a bit more than 14 rectangles as the area of Bhutan. The latter results from renaming ten thousandths as thousandths.

### Common errors

- Some students will not take into account the number of decimal places when they compare numbers.

For example, to compare 0.92 and 0.1234, they will simply think  $92 < 1234$  and say that 0.1234 is greater.

Although you might suggest that they always use equivalent decimals with the same number of decimal places, it might be better to encourage them to start at the tenths place and work toward the right.

### Suggested assessment questions from Practising and Applying

<b>Question 1</b>	to see if students can order a set of numbers involving decimal ten thousandths
<b>Question 4</b>	to see if students can communicate about why one decimal is greater than another decimal
<b>Question 5</b>	to see if students can order a set of decimals that are described in words using different units

### Answers

<b>A. i)</b> 0.003; <i>Sample response:</i> A day is a larger part of a year than an hour is.	<b>B.</b> <i>Sample response:</i> $0.003 = 0.0030$ is 30 ten thousandths and $0.0001$ is only 1 ten thousandth, so $0.003 > 0.0001$ .
<b>1. a)</b> 0.1234; 0.3578; 0.92; 1.2398 <b>b)</b> 3.14578; 3.21514; 3.33; 3.5764  <b>2.</b> <i>Sample response:</i> 0.9981; 0.9991; 0.9992; 0.9993; 0.9994  <b>3.</b> <i>Sample response:</i> 0.0001; 0.0002; 0.0003; 0.0004; 0.0005  <b>4.</b> Yes; [ <i>Sample response:</i> First way: The first number is more than 1000 ten thousandths and the second number is less than 1000 ten thousandths, so the first number is greater. Second way: The first number is greater than one tenth and the second number is less than one tenth.]	<b>5.</b> 26 ten thousandths; 43 hundredths; 512 thousandths  [ <b>6.</b> <i>Sample response:</i> The first number is greater than 4 hundredths, but the second number is less than 2 hundredths, so the first number is greater.]  <b>7. a)</b> Bhutan <b>b)</b> About 14 times as big  [ <b>8.</b> <i>Sample response:</i> Alike: You still look for higher values in the digits that are in the places that are farther left. Different: With decimals, you cannot count digits to decide which value is greater.]

### Supporting Students

#### Struggling students

- Struggling students may have difficulty with **question 6**. Have them use a place value chart or substitute numbers for the blanks.
- For **question 5**, encourage students first to write each decimal in standard form.

## 6.2.3 Introducing Integers

Curriculum Outcomes	Outcome relevance
<b>6-A11 Integers: negative and positive</b> <ul style="list-style-type: none"> <li>develop meaning of integers using models and symbols</li> <li>explore negative integers in context (e.g., temperature, money, sea level heights)</li> <li>understand that each negative integer is the opposite of a positive integer with respect to 0 on a number line</li> <li>understand that 0 is neither positive or negative</li> <li>compare integers</li> </ul>	Students will work with integers as they progress to higher classes in mathematics. This early introduction lays a foundation for that work.

Pacing	Materials	Prerequisites
1 h	None	<ul style="list-style-type: none"> <li>using a number line with whole numbers</li> </ul>

### Main Points to be Raised

- A negative number is a number less than zero.
- A negative integer is the opposite of a positive whole number. It is equally far from zero as the positive integer on the other side.
- Zero is its own opposite.
- A number line showing integers can be either horizontal or vertical. If it is horizontal, the greater integers are to the right. If it is vertical, the greater integers are above the lesser integers.

### Try This — Introducing the Lesson

**A.** Allow students to try this alone or with a partner. While you observe students at work, you might ask questions such as the following:

- What does a temperature of  $-4$  mean? ( $4^\circ$  below  $0^\circ$ )
- What does a temperature of  $-6$  mean? ( $6^\circ$  below  $0^\circ$ )
- Why do you think  $-6$  is a lower temperature? (It is farther below  $0^\circ$ .)

### The Exposition — Presenting the Main Ideas

- Ask students if they know what negative numbers are. If they do, you can build from there. If not, you can start at the beginning.
- Draw a number line on the board. Record the positive counting numbers and zero. Draw dots equally spaced to the left of zero and ask students to suggest what to name those points.
- As you write in  $-1$ ,  $-2$ , and so on, indicate that these are called negative integers. They are also called the opposites of the counting numbers. The counting numbers are called positive integers.
- Point out how opposite integers, like  $-4$  and  $+4$  (or  $4$ ) are equally far from zero.
- Point to two integers, at least one of them being a negative integer, and ask students which integer they think is greater and why. Help them understand that any integer, positive or negative, is greater when it is farther to the right.
- Suggest that students open their texts to **page 170**. Have them observe that number lines can be either horizontal or vertical. Discuss that the greater numbers appear at the top of the vertical number line.

### Revisiting the Try This

**B.** Students might use either a horizontal or vertical number line to answer the question. Many will use a vertical number line if they are familiar with thermometers.

### Using the Examples

- Ask students to work in pairs. One student in each pair should study **example 1** and the other should study **example 2**. After each is very familiar with his or her example, he or she should explain it to the other student.

## Practising and Applying

### Teaching points and tips

**Q 1:** Students can use either a horizontal or vertical number line, as they wish.

**Q 4:** Students might describe  $-4$  in relation to other integers, or they might describe situations or contexts where negative integers would make sense.

**Q 5:** Encourage students to actually move on the number line following the instructions.

**Q 6:** Students should draw a number line to help them answer the question.

**Q 8:** Some students might wonder whether to count zero as a positive integer; it is neither positive nor negative.

### Common errors

- Some students continue to think of a number like  $-6$  as greater than  $-4$  since  $6 > 4$ . If they use a number line, they are less likely to make this error.

### Suggested assessment questions from Practising and Applying

<b>Question 1</b>	to see if students can place integers on a number line
<b>Question 5</b>	to see if students can solve a simple problem involving integer changes
<b>Question 6</b>	to see if students can name an integer based on its relationship to another integer

### Answers

<p><b>A.</b> <math>-6</math>; <i>Sample response:</i> A negative temperature is colder than a positive temperature, so a more negative temperature is even colder.</p>	<p><b>B.</b> <math>-6</math> is below <math>-4</math> on a vertical number line and left of <math>-4</math> on a horizontal number line, so <math>-6</math> is less than <math>-4</math>.</p>
<p><b>1.</b> Number line could be vertical or horizontal:</p>	
<p><b>2.</b> a) <math>-3</math> c) <math>+5</math> or <math>5</math></p> <p><b>3.</b> <math>16</math> or <math>+16</math>, and <math>-16</math></p> <p><b>4.</b> <i>Sample response:</i> <math>4</math> km below sea level; a debt of Nu <math>4</math>; a temperature <math>4^\circ</math> below zero.</p>	<p><b>5.</b> a) <math>-2^\circ</math> b) <math>-3^\circ</math> c) <math>+1^\circ</math> or <math>1^\circ</math></p> <p><b>6.</b> <math>-7</math>, and <math>+1</math> or <math>1</math></p> <p><b>7.</b> <math>-5</math>, <math>-6</math>, or <math>-7</math></p> <p><b>[8.</b> Each positive integer has exactly one opposite negative integer and each negative integer has exactly one opposite positive integer, so they match.]</p>

## Supporting Students

### Struggling students

- Struggling students may have difficulty coming up with contexts for **question 4**. Encourage them to refer to **example 2**.

### Enrichment

- Students can make up sets of clues that other students can use to locate particular integers on a number line. For example, they might locate  $-7$  by referring to other integers it is greater or less than (e.g., an integer is  $5$  less than  $-2$  but  $3$  greater than  $-10$ ) or by referring to specific movements up or down (or left or right) from various other integers (e.g., an integer is  $7$  spaces to the right of  $-14$  but  $6$  spaces to the left of  $-1$ ).

## Chapter 3 Number Theory

### 6.3.1 Prime Numbers

Curriculum Outcomes	Outcome relevance
<b>6-A12 Prime Numbers: distinguish from composites</b> <ul style="list-style-type: none"><li>• understand that a prime number is a number that has exactly two factors</li><li>• model prime numbers as dimensions (other than 1) of unique rectangles with particular whole number areas</li><li>• understand that 1 is not a prime number</li></ul>	The ability to recognize prime numbers provides students with a foundation for calculating common multiples and greatest common factors, simplifying fractions, and determining square roots.

Pacing	Materials	Prerequisites
1 h	• Grid paper or Small Grid Paper (BLM) (optional)	• factoring whole numbers

#### Main Points to be Raised

- In a multiplication equation like  $2 \times 3 = 6$ , the 2 and 3 are called factors, and the 6 is called a multiple.
- A number that has only 1 and itself as factors is called a prime number.
- A prime number can be large or small.
- Every whole number can be written as a product of prime numbers. You can find these factors by starting with any pair of factors and then gradually breaking up each of the factors until only primes are listed.
- 1 is not a prime number; it has only one factor instead of two.

#### Try This — Introducing the Lesson

A. Allow students to try this alone or with a partner. While you observe students at work, you might ask questions such as the following:

- *How wide is your rectangle? How long is it?* (It is 2 units long and 1 unit wide.)
- *How do you know you cannot draw another rectangle?* (If I moved one, two, or three of the seven squares up, I would not have a rectangle anymore.)
- *Which of your rectangles were squares?* (The 2-by-2 square for 4 square units and the 3-by-3 square for 9 square units.)
- *How are these two rectangles alike?* (The 8-by-1 rectangle and the 1-by-8 rectangle are really the same. They each face a different way.)

Note: Some students will say that there is only one possible rectangle for 2, 3, 5, 7 square units, but others will say there are two rectangles. It depends on whether they consider the way the rectangle faces.

#### The Exposition — Presenting the Main Ideas

- Ask students to write the number 15 as a product of two numbers. List their suggestions on the board. Make sure that both  $3 \times 5$  and  $1 \times 15$  are listed. Repeat this with the number 14 and then with the number 13.
- Point out how 13 is different because you could write only one pair of factors. Tell students that because of this, 13 is called a prime number.
- Ask students which of 10, 11, and 12 are prime numbers.
- Now write a number like 30. Ask if it is a prime number. Show how it can be factored, first as  $6 \times 5$ , but then as  $2 \times 3 \times 5$ , which are all prime numbers. Indicate that every whole number can be factored down to prime numbers.
- Tell students that 1 is not a prime number, since it has only one factor (1). Numbers like 11 and 13 have two factors (1 and themselves).
- Allow time for students to read through the exposition on **page 173** of the student text if they wish.

## Revisiting the Try This

**B.** Students can relate the concept of factoring to the concept of creating rectangles with given areas. They will see that a prime number area can only be modelled as a rectangle in one way.

### Using the Examples

- Present the questions from both examples to the students. Ask them to try to solve the questions. They can then compare their work to the two solutions shown in the text. Make sure that students understand that they have to try to divide 89 by every prime number up to 9 to be sure that it is not prime.

For example, students might think that 91 is not prime, if they stopped trying numbers before they reached 7.

Similarly, in **example 2**, they have to try all possible prime number widths (some students might think that they have to try non-primes too; if they do that, do not correct them at this point). If students have not used a rectangle model, discuss the model with them, perhaps using another example.

### Practising and Applying

#### Teaching points and tips

**Q 1:** Some students will approach this by writing down all possibilities and eliminating non-primes. Other students will simply test each number. Still others will test only the odd numbers, knowing that the even numbers need not be tested (other than 2).

**Q 2:** Students need to recognize that, by definition, an even number is a multiple of 2. That means it has factors other than 1 and itself, unless it is 2.

**Q 4:** Students might observe from **question 1** that primes can be two apart (e.g., 41 and 43), but realize that they cannot be closer since even and odd numbers alternate and even numbers cannot be prime.

**Q 5:** Students need only try values with odd digits.

**Q 7:** You may wish to discuss with students why they only have to try prime values up to 21. This is because if a number has any non-prime factors, it also has prime factors. If one factor is greater than 21, the other factor has to be less since  $21 \times 21 = 441$ , and 423 is less.

#### Suggested assessment questions from Practising and Applying

<b>Question 1</b>	to see if students can decide whether a number is prime
<b>Question 6</b>	to see if students can factor a whole number into its prime factors
<b>Question 7</b>	to see if students can describe the process of deciding whether a number is prime

### Answers

<p><b>A. i)</b>          For 2: 2 by 1          For 4: 4 by 1 and 2 by 2          For 6: 6 by 1 and 2 by 3          For 8: 8 by 1 and 4 by 2</p>	<p>For 3: 3 by 1          For 5: 5 by 1          For 7: 7 by 1          For 9: 9 by 1 and 3 by 3</p>	<p><b>ii)</b> Only one rectangle was possible for 2, 3, 5, and 7, but I could draw more than one rectangle for the other numbers.</p> <p><b>B. i)</b> 2, 3, 5, and 7  <b>ii)</b> If I was able to make only one rectangle for a number, then the number was a prime number.</p>
<p><b>1.</b> 2, 3, 5, 7, 11, 13, 17, 19, 23, 29, 31, 37, 41, 43, 47, 53, 59, 61, 67, 71, 73, 79, 83, 89, 97</p> <p><b>[2.</b> Every other even number has at least 3 factors: 1, itself, and 2.]</p> <p><b>[3.</b> Each of the other numbers with 5 as the ones digit is a multiple of 5 and has at least 3 factors: 1, itself, and 5.]</p> <p><b>4.</b> They can be 2 apart, like 11 and 13; [They cannot be closer because if they were 1 apart, one number would be even and therefore not prime.]</p>	<p><b>5.</b> <i>Sample response:</i> 17 and 71</p> <p><b>6.</b> <i>Sample response:</i>  <math>10 = 2 \times 5</math>; <math>20 = 2 \times 2 \times 5</math>;  <math>70 = 7 \times 2 \times 5</math>; <math>100 = 2 \times 2 \times 5 \times 5</math></p> <p><b>[7.</b> <i>Sample response:</i>          I would try to divide 423 by numbers up to about 200 to see if any of them divided into it evenly.]</p>	

## Supporting Students

### *Struggling students*

- If students have trouble dividing, they will have difficulty deciding whether a number is a prime number. You might have them go the other way, listing multiples of 2, then 3, and so on, and eliminating values that are not prime.

### *Enrichment*

- Students might look for primes greater than 100. They might also determine how many numbers they have to divide by before they can be sure a number is a prime number.

## CONNECTIONS: The Sieve of Eratosthenes

- This connection is designed to show students an historical approach to determining whether numbers are prime numbers. This approach is still used by mathematicians to decide whether or not very large numbers are prime. The only difference is that now computers are programmed to follow the steps.

1. Yes, except for 1.

[2. *Sample response:*

He had already crossed off the multiples of 8 since they are all multiples of 2. He had already crossed off the multiples of 9 since they are all multiples of 3. And, if a number is 100 or less, one of the factors has to be less than 10 or the product is greater than  $10 \times 10$ .]

3. Create a chart that goes up to 200 instead of 100 and use the same technique.

## 6.3.2 EXPLORE: Square and Triangular Numbers

Curriculum Outcomes	Outcome relevance
<p><b>6-C6 Square and Triangular Numbers: represent pictorially and symbolically</b></p> <ul style="list-style-type: none"> <li>• represent square and triangular numbers pictorially and symbolically to show both geometric and numerical patterns</li> <li>• understand that square numbers may be represented in square arrays and are the products of numbers multiplied by themselves</li> <li>• understand that a triangular number is half the number in an array with dimensions that are one unit apart</li> </ul>	<p>This essential exploration will allow students to become familiar with number patterns that are useful in higher mathematics. By seeing the numbers both pictorially and numerically, students will gain insight into the patterns.</p>

Pacing	Materials	Prerequisites
40 min	<ul style="list-style-type: none"> <li>• Grid paper or Small Grid Paper (BLM) (optional)</li> </ul>	<ul style="list-style-type: none"> <li>• recognizing increasing patterns</li> <li>• knowing that a square has equal length and width</li> </ul>

### Exploration

• Read through the introduction to the lesson with the students to make sure they understand what square and triangular numbers are. Test their understanding by asking what the next square number is (25). Then ask what the first, second, and third triangular numbers are (1, 3, and 6).

Encourage students to work in pairs. They can use grid paper if they wish. While you observe students at work, you might ask questions such as the following:

- *How did you find more square numbers?* (I added one row and one column to the previous square number.)
- *Does the distance between square numbers increase or decrease?* (The distance increases but it is always the next odd number.)
- *How many rows are in your diagram for the 10th triangular number?* (There are 10 rows, starting with a row with 1 X and ending with a row with 10 Xs.)
- *How far apart are the triangular numbers you used to make rectangles?* (I always used one triangular number and the next triangular number.)
- *How do you know that you can put two copies of the 12th triangular number together to make a rectangle?* (I would turn one copy around. The short row on one copy would go with the long row on the other copy, so there would be the same total number of squares in each row.)

### Observe and Assess

As students work, notice the following:

- Do they extend the patterns correctly?
- Do they put together pairs of triangular numbers correctly to make rectangles and squares?
- Do they see the relationships between the numerical and visual patterns?
- Can they explain their thinking effectively?

### Share and Reflect

After students have had sufficient time to work through the exploration, discuss questions such as these:

- *Could a square number also be a triangular number?*
- *If you put together two square numbers under 100, can you get another square number?*
- *If you put together two triangular numbers under 100, can you get another triangular number?*
- *Why do triangular and square numbers alternate between being odd and even?*



## Answers

**A. i)** 1, 4, 9, 16, 25, 36, 49, 64, 81, 100, 121, 144, 169, 196

**ii)** They are always separated by odd numbers like 3, 5, 7, 9, ....

**B.** I can draw a grid with 15 rows of 15 squares each. The area is  $15 \times 15$ .

**C.** 1, 3, 6, 10, 15, 21, 28, 36, 45, 55, 66, 78, 91

**D. i)**

```

X
X X
X X X
X X X X
X X X X X
X X X X X X
X X X X X X X
X X X X X X X X
X X X X X X X X X
X X X X X X X X X X
    
```

**ii)** Each row has 1, 2, 3, 4, ..., 9, 10 Xs in it and you have to count all the rows.

**E. i) Sample response:**

10 + 15 makes a 5-by-5 rectangle;

15 + 21 makes a 6-by-6 rectangle

21 + 28 makes a 7-by-7 rectangle

**ii)** It is a 20-by-20 rectangle, so the sum is 400.

**F. i) Sample response:**

3-by-4 rectangle

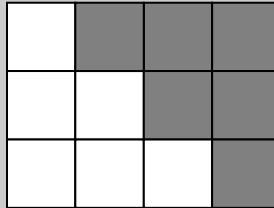

4-by-5 rectangle

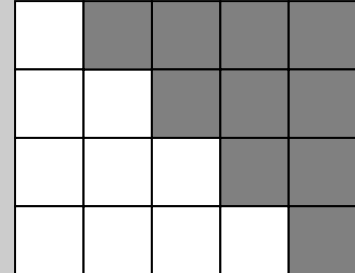

**ii) Sample response:**

The second triangular number is the white squares (3) and it is half of the whole rectangle, which is half of  $2 \times 3$ .

**iii)** It is half of  $20 \times 21 = 420$ , so it is 210.

## Supporting Students

### Struggling students

- Some students may struggle to recognize the patterns in **parts E ii) and F iii)**. They may need to try more examples before they are ready to generalize.

### Enrichment

- Some students might be ready to explore other properties of triangular numbers or square numbers.

For example, they might observe that 1 more than 9 times a triangular number is also a triangular number, 1 more than 8 times a triangular number is always a square number, and some triangular numbers are products of consecutive numbers (e.g.,  $6 = 1 \times 2 \times 3$ ;  $120 = 4 \times 5 \times 6$ ;  $210 = 5 \times 6 \times 7$ ).

## CONNECTIONS: Triangular Numbers as Products

- The triangular numbers have many interesting properties (see Enrichment ideas in the previous lesson). This Connection highlights one of these properties (each triangular number can be written as a product of two numbers) following a pattern set by the products shown on **page 177** of the student text.

### Answers

210;

[The first factor is 10 since each counting number is repeated twice as the first factor.

The second factor is 21 since each odd number except 1 is repeated twice.

$10 \times 21 = 210$ ]

## 6.3.3 EXPLORE: Factors

Curriculum Outcomes	Outcome relevance
<p><b>6-A13 Factors: whole numbers</b></p> <ul style="list-style-type: none"> <li>conclude that a number is a multiple of any of its factors</li> <li>find factors by dividing systematically</li> <li>understand, through investigation, that the greatest factor is always the number itself and the least factor is always 1</li> <li>understand, through investigation, that the second greatest factor is always <math>\frac{1}{2}</math> the number or less</li> </ul>	<p>To prepare for work with common factors, it is important that students first develop a technique for finding all the factors of a number.</p>

Pacing	Materials	Prerequisites
40 min	None	<ul style="list-style-type: none"> <li>dividing whole numbers</li> </ul>

### Exploration

• Make sure students read through the introduction to the exploration and understand what a factor and a multiple are. Model how to find factors of, for example, 20, by dividing it first by 1, then by 2, then by 3, and so on until all factors are determined. Some students will realize that since factors come in pairs, they do not have to keep dividing once the second factor is less than the first factor.

Encourage students to work in pairs. While you observe students at work, you might ask questions such as the following:

- How do you know you have all the possibilities for 45?* (I knew not to try even numbers because 45 is odd, so I just tried odd factors. I got 1 with 45, 3 with 15, and 5 with 9. 7 did not work. I did not have to try 9 again because I already had it.)
- Why is 1 always the least factor?* (It is always a factor because you can write any number as 1 times itself. It is the least factor because 1 is the least possible whole number.)
- Why is the second greatest factor of 36 half of 36?* (After I divide 36 by 1, the next thing I can try is  $36 \div 2$ . The answer will always be half of 36 since I am dividing by 2.)
- Why is the second greatest factor of 45 not  $45 \div 2$ ?* (2 is not a factor of 45, so I divided by 3. The result is one third of 45 and not one half of 45.)
- Does 100 or 101 have more factors? How do you know? What about 100 compared to 200?* (100 has more factors than 101 since 101 is prime. 200 has more factors than 100 since it has all the factors 100 has, and 200 is another factor.)

### Observe and Assess

As students work, notice the following:

- Do they correctly determine one pair of factors for a number?
- Do they continue to factor until they have found all the possible factors?
- Can they explain why 1 is always a factor of a number?
- Do they recognize that the second greatest factor of a number is one half of the number if it is even?
- Do they recognize that the second greatest factor of a number is less than half the number if the number is odd?

### Share and Reflect

After students have had sufficient time to work through the exploration, discuss questions such as these:

- How did you make sure you had not missed any factors?*
- When did you stop looking for more factors?*
- Predict whether 250 will have a large number of factors. How did you decide?*

## Answers

**A.**  $45 = 1 \times 45$ ;  $45 = 3 \times 15$ ;  $45 = 5 \times 9$

$36 = 1 \times 36$ ;  $36 = 2 \times 18$ ;  $36 = 3 \times 12$ ;  $36 = 4 \times 9$ ;  $36 = 6 \times 6$

$60 = 1 \times 60$ ;  $60 = 2 \times 30$ ;  $60 = 3 \times 20$ ;  $60 = 4 \times 15$ ;  $60 = 5 \times 12$ ;  $60 = 6 \times 10$

**ii)** You can divide 45 by 1, 3, 5, 9, and 15 with no remainder. It is the same for 36 and 60.

**iii)** The least factor is 1. The greatest factor is the number itself.

**iv)** Least = 1, greatest = 80

**B. i)** *Sample response:*

Here are the multiplications for 60:

$60 = 1 \times 60$ ;  $60 = 2 \times 30$ ;  $60 = 3 \times 20$ ;  $60 = 4 \times 15$ ;  $60 = 5 \times 12$ ;  $60 = 6 \times 10$

I can see that as one factor increases, the other factor decreases. If I want the greatest factor of 60, which is 60, I have to multiply by the least factor of 60, which is 1. If I want the second greatest factor, 30, I have to multiply by the next-to-least factor, which is 2.

**ii)** *Sample response:*

60 is even, so I knew 2 would divide into it to get the next greatest factor, 30. 45 is not even, so I have to look for the next number that will divide into it evenly. That number is 3.

**iii)** 60; I predict 60 because 60 is an even number so I know 2 is a factor and  $2 \times 60 = 120$ .

20; I predict 20 because 40 is an even number so I know 2 is a factor and  $2 \times 20 = 40$ .

25; I predict 25 because 2, 3, and 4 do not divide evenly into 25 but 5 does and  $5 \times 25 = 125$ .

**C.** No; *Sample response:*

The factors of 25 are 1, 5, and 25.

The factors of 24 are 1, 2, 3, 4, 6, 8, 12, and 24.

24 has more factors even though it is less than 25.

## Supporting Students

### *Struggling students*

- Some students who can find the factors may have difficulty identifying which factor is second greatest. Have them try more examples, each time ordering the factors by value.

### *Enrichment*

- Ask students to develop a rule to predict whether the number of factors of a number will be odd or even by trying a number of examples.

## GAME: Down to Prime

- This game provides an opportunity for students to practise factoring numbers and recognizing prime numbers.
- Students may notice that if they roll a prime number for their first number, the only number they can subtract is 1.
- For a variation of the game, students might use two different dice where one die is always the tens digit and the other die is always the ones digit. That eliminates their ability to choose the starting number.

## 6.3.4 Common Factors

Curriculum Outcomes	Outcome relevance
<b>6-A14 Common Factors: whole numbers</b> <ul style="list-style-type: none"> <li>• find factors in a systematic way</li> <li>• understand that 1 is always a common factor of any two numbers</li> <li>• find common factors of two or three numbers</li> </ul>	Students who are able to find common factors will be in a better position to simplify fractions. They also have an additional tool to solve certain kinds of real-world problems.

Pacing	Materials	Prerequisites
1 h	None	• dividing to find factors

### Main Points to be Raised

- If a number is a factor of two or more other numbers, it is called a common factor of those other numbers.
- To find a common factor of two numbers, you can list the factors of both numbers and look for numbers that appear on both lists.
- Every pair of whole numbers have a common factor of 1.
- The list of factors for a number can be organized in pairs; as one factor increases, the other decreases.
- You can draw a factor rainbow to show how the factors of a number pair up.

### Try This — Introducing the Lesson

**A.** Allow students to try this alone or with a partner. While you observe students at work, you might ask questions such as the following:

- *How many 1 cm-by-1 cm squares could they cut from the cloth?* ( $90 \times 60 = 5400$  squares)
- *Could they cut 2 cm-by-2 cm squares from the cloth? How do you know?* (Yes. They could get 45 squares across the 90 cm length and 30 squares across the 60 cm width.)
- *Why could they not use 4 cm-by-4 cm squares?* (If they divide the 90 cm length into sections of 4 cm, there are only 2 cm left at the end and they cannot make the last square.)
- *How did you decide which sizes to try?* (I looked for numbers that would divide evenly into 60 and 90.)

### The Exposition — Presenting the Main Ideas

- Work through the exposition with the students, making sure they understand both how to show all the factors (whether using a factor rainbow or not) and how to make sure they have listed all common factors.
- Point out that 1 is a common factor of any two whole numbers because 1 is a factor of every whole number.
- You may wish to tell students that the term “factor” is only applied to integers. It is not used for fractions or decimals.

### Revisiting the Try This

**B.** Students will probably notice that the answers they found in **part A** are the common factors of 60 and 90. Point out that this kind of problem is an application of the concept of common factors.

### Using the Examples

- Work through **example 1** with the students. Make sure they understand why factoring a number means finding the length and width of rectangles with that area (since the area is the product of the length and width).
- Read the problem in **example 2** and have students try it before they look at the solution in the student text. They can then check their work against the solution on **page 182**.



## Supporting Students

### *Struggling students*

- Some of the questions, for example, **questions 4, 7, 8, and 9**, require abstract generalizations. You may wish to partner struggling students with other students for these questions.
- For **question 5**, you might suggest that students first try to draw the chairs in equal rows, to see that the number of rows must be a factor of 54. Then have them try to seat the students equally within the rows to see why the number of students in a row must be a factor of 48 and so the only arrangements possible are ones that allow for that.

### *Enrichment*

- Students might suggest other properties than those in **questions 4, 7, and 8** that are true about common factors. For example, they might note that the only common factor possible for consecutive numbers is 1 or that the list of common factors for the double of a number is always the same list as for the original number with only one extra value — the double itself.

## UNIT 6 Revision

Pacing	Materials
2 h	• Place Value Charts II and III (BLM) (optional)

Question(s)	Related Lesson(s)
1 – 3	Lesson 6.1.2
4 and 5	Lesson 6.1.3
6 – 10	Lesson 6.2.1
11 – 13	Lesson 6.2.2
14	Lesson 6.2.1
15 – 18	Lesson 6.2.3
19	Lesson 6.3.1
20	Lesson 6.3.2
21 – 24	Lesson 6.3.4[

### Revision Tips

**Q 3:** Students need to realize that because there is a “twenty”, the digit 2 must appear in either the tens place, the ten thousands place, or the ten millions place.

**Q 5:** Students might find this easier if they either write all the numbers in standard form or if they rewrite each number as a number of hundred millions.

**Q 8:** There are many correct answers to each part.

**Q 10:** Students need to use what they know about metric unit relationships to answer this.

**Q 12 b):** Students should respond to this in terms of the context, not just the numbers.

**Q 14:** Students need to think of 0.01 as 100 groups of ten thousandths.

**Q 19:** Students might choose specific examples and try factoring them.

### Answers

<p><b>1. a)</b> 6,022,403,000      <b>b)</b> 308,087,086  <b>c)</b> 2,103,000,017</p> <p><b>2. Sample responses:</b>  <b>a)</b> <math>4 \times 1,000,000,000 + 2 \times 100,000,000 + 1 \times 100,000 + 4 \times 10,000 + 6 \times 1000 + 1 \times 100</math>;            4 billions + 2 hundred millions + 1 hundred thousand + 4 ten thousands + 6 thousands + 1 hundred  <b>b)</b> <math>3 \times 100,000,000 + 5 \times 10,000,000 + 6 \times 1,000,000 + 1 \times 100,000 + 2 \times 100</math>;            3 hundred millions + 5 ten millions + 6 millions + 1 hundred thousand + 2 hundreds</p> <p><b>3. Sample response:</b>            22,500,000; 20,500,002; 20,502,000</p> <p><b>4. a)</b> 800,000,000      <b>b)</b> 2,320,000,000  <b>c)</b> 620,000      <b>d)</b> 5,700,000,000</p> <p><b>5.</b> 28 ten million, 0.9 billion, 1001 million, 1,002,003 thousand</p> <p><b>6. a)</b> 3      <b>b)</b> 0      <b>c)</b> 4</p>	<p><b>7. a)</b> 0.0054      <b>b)</b> 0.065  <b>c)</b> 0.0650      <b>d)</b> 0.0324</p> <p><b>8. Sample responses:</b>  <b>a)</b> 0.1061      <b>b)</b> 0.1208</p> <p><b>9. Sample responses:</b>  <b>a)</b> 3 and 12 thousandths, or 3012 thousandths  <b>b)</b> 4 and 123 thousandths, or 4 and 1230 ten thousandths  <b>c)</b> 4 and 1 tenth, or 4 and 100 thousandths  <b>d)</b> 3 and 4 thousandths, or 3 and 40 ten thousandths</p> <p><b>10.</b> Yes; [<i>Sample response:</i>            1000 m = 1 km, so 1 m = 0.001 km;            0.001 = 1 thousandth or 10 ten thousandths;            50 cm is half a metre, so 50 cm = half of 10 ten thousandths = 5 ten thousandths, or 0.0005.]</p> <p><b>11.</b> Yes; [<i>Sample response:</i>            Both numbers have 1 whole, 2 tenths, and 3 hundredths, but the first number has only 4 thousandths, while the second number has 6 thousandths.]</p>
--	---

**Answers [Continued]**

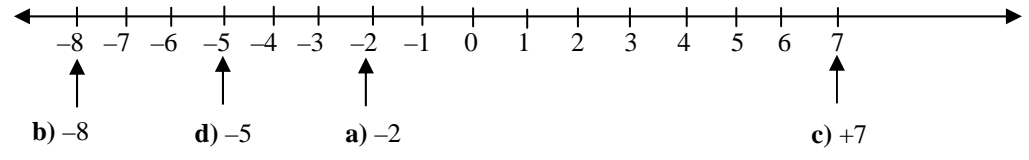
<p><b>12. a)</b> 0.0369  <b>b)</b> <i>Sample response:</i>          The people in Australia are more spread out.</p>	<p><b>13.</b> 891 ten thousandths, 36 hundredths, 1234 thousandths   <b>14.</b> About 30 km</p>
<p><b>15.</b></p> 	
<p><b>16. a)</b> +6 or 6                      <b>b)</b> -12  <b>c)</b> +9 or 9                        <b>d)</b> -8</p> <p><b>17.</b> +1 or 1</p> <p><b>18.</b> +10 (or 10), or +11 (or 11)</p> <p>[<b>19.</b> If ▲ is a multiple of 4, it can be grouped in 4s. If you add 20 to ▲, it is just 5 more groups of 4, so ▲ + 20 can still be grouped in 4s and is not prime.]</p> <p>[<b>20. Sample responses:</b>  <b>a)</b> <math>36 + 64 = 100</math> so the sum can be a square number, but <math>1 + 4 = 5</math> and 5 is not a square number.  <b>b)</b> <math>21 + 28 = 49</math> which is a square number, but <math>15 + 28 = 43</math> and that is not a square number.]</p>	<p><b>21. Sample responses:</b>  <b>a)</b> 2                                      <b>b)</b> 18  <b>c)</b> 5                                      <b>d)</b> 50</p> <p><b>22.</b> The side lengths could be 1 cm, 2 cm, 4 cm, 5 cm, 10 cm, or 20 cm.</p> <p><b>23.</b> As many factors as the lower number has; [If you can make a rectangle to show factors of the lower number, you can triple one dimension and you will have factors of the triple. The only missing factor is the higher number.]</p>



## UNIT 6 Number Relationships Test

1. Write each in standard form.

- a) three billion, forty-two million, eight
- b) 1420 million, thirty-five thousand, forty-seven

2. Write each in expanded form in two ways.

- a) 1,003,000,020
- b) 342,100,006

3. Explain why 3.04 billion  $<$  3400 million.

4. Order from greatest to least

- 348.2 million
- 13.7 hundred million
- 572,000 thousand

5. Write each as a decimal.

- a) sixteen ten thousandths
- b) four hundred three thousandths
- c) 80,003 ten thousandths

6. Describe two different ways to read each decimal.

- a) 1.4820
- b) 0.0300
- c) 2.35

7. Order from least to greatest.

- 37 thousandths
- 217 ten thousandths
- 5 tenths
- 302 thousandths

8. What do you know about the number in the blank below?

\_\_\_ ten thousandths  $>$  42 hundredths

9. In a group of 10,000 people, about 1500 are left-handed. What decimal describes the part of a group of 100 people that are left-handed? How do you know?

10. Sketch a number line and mark these integers on it.

- a)  $-3$
- b)  $-10$
- c)  $+4$

11. List all the integers that match each description.

- a) 5 less than  $-3$
- b) 3 more than  $-10$
- c) between the opposites of  $+2$  and  $-5$

12. How can you be sure that 101 is a prime number?

13. Factor each number into the product of prime factors.

- a) 360
- b) 88

14. a) Sketch a picture to show the 7th triangular number.

b) If you add the number in **part a)** to the 6th triangular number, the result is a square number. Use your picture from **part a)** to show why this is true.

15. List five common factors of 360 and 144.

16. Both a 24 cm strip of wood and an 18 cm strip of wood can be measured exactly using a smaller strip of wood. How long might the smaller strip of wood be?

## UNIT 6 Test

Pacing	Materials
1 h	• Place Value Charts II and III (BLM) (optional)

Question(s)	Related Lesson(s)
1 and 2	Lesson 6.1.2
3 and 4	Lesson 6.1.3
5 and 6	Lesson 6.2.1
7 and 8	Lesson 6.2.2
9	Lesson 6.2.1
10 and 11	Lesson 6.2.3
12 and 13	Lesson 6.3.1
14	Lesson 6.3.2
15 and 16	Lesson 6.3.4

Select questions to assign according to the time available.

### Answers

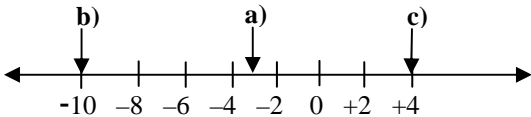
<p><b>1. a)</b> 3,042,000,008                      <b>b)</b> 1,420,035,047</p> <p><b>2. a)</b> 1 billion + 3 millions + 2 tens;  <math>1 \times 1,000,000,000 + 3 \times 1,000,000 + 2 \times 10</math>  <b>b)</b> 3 hundred millions + 4 ten millions + 2 millions + 1 hundred thousand + 6 ones;  <math>3 \times 100,000,000 + 4 \times 10,000,000 + 2 \times 1,000,000 + 1 \times 100,000 + 6 \times 1</math></p> <p><b>3. Sample response:</b>            3.04 billion is the same as 304 ten million or 3040 million.            Since <math>3040 &lt; 3400</math>, 3.04 billion <math>&lt;</math> 3400 million.</p> <p><b>4.</b> 13.7 hundred million, 572,000 thousand, 348.2 million</p> <p><b>5. a)</b> 0.0016              <b>b)</b> 0.403              <b>c)</b> 8.0003</p> <p><b>6. Sample responses:</b>  <b>a)</b> 14,820 ten thousandths or 1 and 4820 ten thousandths  <b>b)</b> 3 hundredths or 300 ten thousandths  <b>c)</b> 235 hundredths or 2350 thousandths</p> <p><b>7.</b> 217 ten thousandths, 37 thousandths, 302 thousandths, 5 tenths</p> <p><b>8.</b> The number must be greater than 4200.</p>	<p><b>9.</b> 0.15; I wrote the fraction <math>\frac{1500}{10,000}</math> and then made an equivalent fraction by dividing the numerator and denominator by 100 to get <math>\frac{15}{100}</math>. I wrote it as a decimal.</p> <p><b>10.</b></p>  <p><b>11. a)</b> -8                      <b>b)</b> -7                      <b>c)</b> -1, 0, 1, 2, 3, 4</p> <p><b>12. Sample response:</b>            I tried dividing it by 2, 3, 4, 5, 6, 7, 8, 9, 10, and 11 and there was always a remainder. I did not try higher numbers because if there were a factor greater than 11, there would also have to be a factor that was less than 11 and I had already tried those.</p> <p><b>13. a)</b> <math>360 = 2 \times 2 \times 2 \times 3 \times 3 \times 5</math>  <b>b)</b> <math>88 = 2 \times 2 \times 2 \times 11</math></p> <p><b>14. a) and b) Sample responses:</b></p> <table style="border: none;"> <tr> <td style="padding-right: 20px;">x 0 0 0 0 0 0</td> <td rowspan="7" style="vertical-align: top;">The Xs represent the 7th triangular number and the 0s represent the 6th triangular number. Together they make a 7-by-7 square.</td> </tr> <tr> <td>x x 0 0 0 0</td> </tr> <tr> <td>x x x 0 0 0</td> </tr> <tr> <td>x x x x 0 0</td> </tr> <tr> <td>x x x x x 0</td> </tr> <tr> <td>x x x x x x 0</td> </tr> <tr> <td>x x x x x x x</td> </tr> </table> <p><b>15. Sample response:</b> 1, 2, 3, 6, 9</p> <p><b>16.</b> 1 cm, 2 cm, 3 cm, or 6 cm</p>	x 0 0 0 0 0 0	The Xs represent the 7th triangular number and the 0s represent the 6th triangular number. Together they make a 7-by-7 square.	x x 0 0 0 0	x x x 0 0 0	x x x x 0 0	x x x x x 0	x x x x x x 0	x x x x x x x
x 0 0 0 0 0 0	The Xs represent the 7th triangular number and the 0s represent the 6th triangular number. Together they make a 7-by-7 square.								
x x 0 0 0 0									
x x x 0 0 0									
x x x x 0 0									
x x x x x 0									
x x x x x x 0									
x x x x x x x									

## UNIT 6 Performance Task — 30 Digits for Seven Numbers

You need a set of 30 digit cards, three each of the digits 0 to 9. Use all 30 digit cards to create one number that matches each clue below. You can use as many decimal points as you need. When you have made all seven numbers, you must display them all at the same time, using each digit card only once.

*Alternative materials*

You could use three suits from a deck of playing cards without the face cards (use the Aces for the digit 1 and the Tens for the digit 0).

- i) a prime number between 90 and 100
- ii) a square number that is a multiple of 10
- iii) a triangular number between 60 and 100
- iv) a common factor of 25 and 75
- v) a number between 2.4 billion and 24.6 hundred million
- vi) 849.73 thousand in standard form
- vii) "eleven thousand two hundred thirty-five ten thousandths" in standard form

Digit cards

0	1	2	3	4	5
6	7	8	9	0	1
2	3	4	5	6	7
8	9	0	1	2	3
4	5	6	7	8	9

## UNIT 6 Performance Task

Curriculum Outcomes Assessed	Pacing	Materials
<b>6-A9</b> Large Numbers: reading and writing <b>6-A10</b> Place Value: understanding place value patterns <b>6-A12</b> Prime Numbers: distinguish from composites <b>6-A14</b> Common Factors: whole numbers <b>6-C6</b> Square and Triangular Numbers: represent pictorially and symbolically	1 h	None

### How to Use This Performance Task

- You might use this task as a rich problem to assess student understanding of a number of outcomes in this unit. It could replace or supplement the unit test. It could also be used as enrichment material for some students.
- You can assess performance on the task using the rubric on the next page.

### Sample Solution

i) a prime number between 90 and 100	97
ii) a square number that is a square of a multiple of 10	900
iii) a triangular number between 60 and 100	66
iv) a common factor of 25 and 75	25
v) a number between 2.4 billion and 24.6 hundred million	2,451,346,788
vi) 849.73 thousand in standard form	849,730
vii) "eleven thousand two hundred thirty-five ten thousandths" in standard form	1.1235

### UNIT 6 Performance Task Assessment Rubric

<i>The student</i>	<b>Level 4</b>	<b>Level 3</b>	<b>Level 2</b>	<b>Level 1</b>
<b>Identifies numbers in terms of place value</b>	Correctly identifies both large and small numbers that fit the given rules and recognizes all the numbers that can be used to fit each rule	Correctly identifies both large and small numbers that fit the given rules and recognizes some choices in the numbers that can be used to fit each rule	Correctly identifies many large and small numbers that fit the given rules	Has difficulty identifying either or both of the large and small numbers that fit the given rules
<b>Identifies prime numbers, square and triangular numbers, and common factors</b>	Correctly identifies the prime, square, triangular, and common factor numbers that fit the given rules, and recognizes all the numbers that can be used to fit each rule	Correctly identifies the prime, square, triangular, and common factor numbers that fit the given rules, and recognizes some choices in the numbers that can be used to fit each rule	Correctly identifies many of the prime, square, triangular, and common factor numbers that fit the given rules	Has difficulty identifying the prime, square, triangular, and common factor numbers that fit the given rules
<b>Solves the problem of using all the digits</b>	Insightfully chooses among the possible numbers to fit each rule	Sensibly chooses among the possible numbers to fit each rule	Makes a number of reasonable choices in deciding which numbers fit each rule	Has difficulty making good decisions about which digits to use where

# UNIT 6 Blackline Masters

## BLM 1 Place Value Charts II

Billions	Millions			Thousands			Ones		
One	Hundred	Ten	One	Hundred	Ten	One	Hundred	Ten	One

Billions	Millions			Thousands			Ones		
One	Hundred	Ten	One	Hundred	Ten	One	Hundred	Ten	One

Billions	Millions			Thousands			Ones		
One	Hundred	Ten	One	Hundred	Ten	One	Hundred	Ten	One

Billions	Millions			Thousands			Ones		
One	Hundred	Ten	One	Hundred	Ten	One	Hundred	Ten	One

Billions	Millions			Thousands			Ones		
One	Hundred	Ten	One	Hundred	Ten	One	Hundred	Ten	One

**BLM 2 Place Value Charts III**

Tens	Ones	Tenths	Hundredths	Thousandths	Ten thousandths

Tens	Ones	Tenths	Hundredths	Thousandths	Ten thousandths

Tens	Ones	Tenths	Hundredths	Thousandths	Ten thousandths

Tens	Ones	Tenths	Hundredths	Thousandths	Ten thousandths

Tens	Ones	Tenths	Hundredths	Thousandths	Ten thousandths

Tens	Ones	Tenths	Hundredths	Thousandths	Ten thousandths

**BLM 3 100 Charts**

1	2	3	4	5	6	7	8	9	10
11	12	13	14	15	16	17	18	19	20
21	22	23	24	25	26	27	28	29	30
31	32	33	34	35	36	37	38	39	40
41	42	43	44	45	46	47	48	49	50
51	52	53	54	55	56	57	58	59	60
61	62	63	64	65	66	67	68	69	70
71	72	73	74	75	76	77	78	79	80
81	82	83	84	85	86	87	88	89	90
91	92	93	94	95	96	97	98	99	100

1	2	3	4	5	6	7	8	9	10
11	12	13	14	15	16	17	18	19	20
21	22	23	24	25	26	27	28	29	30
31	32	33	34	35	36	37	38	39	40
41	42	43	44	45	46	47	48	49	50
51	52	53	54	55	56	57	58	59	60
61	62	63	64	65	66	67	68	69	70
71	72	73	74	75	76	77	78	79	80
81	82	83	84	85	86	87	88	89	90
91	92	93	94	95	96	97	98	99	100

1	2	3	4	5	6	7	8	9	10
11	12	13	14	15	16	17	18	19	20
21	22	23	24	25	26	27	28	29	30
31	32	33	34	35	36	37	38	39	40
41	42	43	44	45	46	47	48	49	50
51	52	53	54	55	56	57	58	59	60
61	62	63	64	65	66	67	68	69	70
71	72	73	74	75	76	77	78	79	80
81	82	83	84	85	86	87	88	89	90
91	92	93	94	95	96	97	98	99	100

1	2	3	4	5	6	7	8	9	10
11	12	13	14	15	16	17	18	19	20
21	22	23	24	25	26	27	28	29	30
31	32	33	34	35	36	37	38	39	40
41	42	43	44	45	46	47	48	49	50
51	52	53	54	55	56	57	58	59	60
61	62	63	64	65	66	67	68	69	70
71	72	73	74	75	76	77	78	79	80
81	82	83	84	85	86	87	88	89	90
91	92	93	94	95	96	97	98	99	100

1	2	3	4	5	6	7	8	9	10
11	12	13	14	15	16	17	18	19	20
21	22	23	24	25	26	27	28	29	30
31	32	33	34	35	36	37	38	39	40
41	42	43	44	45	46	47	48	49	50
51	52	53	54	55	56	57	58	59	60
61	62	63	64	65	66	67	68	69	70
71	72	73	74	75	76	77	78	79	80
81	82	83	84	85	86	87	88	89	90
91	92	93	94	95	96	97	98	99	100

1	2	3	4	5	6	7	8	9	10
11	12	13	14	15	16	17	18	19	20
21	22	23	24	25	26	27	28	29	30
31	32	33	34	35	36	37	38	39	40
41	42	43	44	45	46	47	48	49	50
51	52	53	54	55	56	57	58	59	60
61	62	63	64	65	66	67	68	69	70
71	72	73	74	75	76	77	78	79	80
81	82	83	84	85	86	87	88	89	90
91	92	93	94	95	96	97	98	99	100





# UNIT 7 DATA AND PROBABILITY

## UNIT 7 PLANNING CHART

	Outcomes or Purpose	Suggested Pacing	Materials	Suggested Assessment
Getting Started SB p. 185 TG p. 256	Review prerequisite concepts, skills, and terminology and pre-assessment	1 h	<ul style="list-style-type: none"> <li>• Dice</li> <li>• 10 counters or small objects</li> <li>• Grid paper or Small Grid Paper (BLM)</li> </ul>	All questions
<b>Chapter 1 Collecting Data</b>				
7.1.1 Choosing a Sample SB p. 187 TG p. 259	<b>6-F1 Evaluate Data: choose appropriate samples</b> <ul style="list-style-type: none"> <li>• consider the issue of sampling (sources of bias and sample size)</li> </ul>	40 min	None	Q1, 2, 3
7.1.2 EXPLORE: Sample Size (Essential) SB p. 189 TG p. 261	<b>6-G1 Reliability: evaluate</b> <ul style="list-style-type: none"> <li>• evaluate sampling results</li> <li>• understand that data from larger samples generally produce more reliable probabilities</li> </ul>	1 h	<ul style="list-style-type: none"> <li>• Watches or clocks</li> <li>• Dice</li> </ul>	Observe and Assess questions
<b>Chapter 2 Graphing Data</b>				
7.2.1 Double Bar Graphs with Intervals SB p. 191 TG p. 263	<b>6-F2 Bar and Double Bar Graphs: construct and interpret</b> <ul style="list-style-type: none"> <li>• construct and interpret bar graphs and double bar graphs using intervals</li> </ul>	1.5 h	<ul style="list-style-type: none"> <li>• Watch or stopwatch</li> <li>• Lined paper, grid paper, or Small Grid Paper (BLM)</li> </ul>	Q2, 3, 4
7.2.2 Stem and Leaf Plots SB p. 195 TG p. 267	<b>6-F3 Stem and Leaf Plots: grouping and displaying data</b> <ul style="list-style-type: none"> <li>• construct to display grouped numerical data (e.g., heights of students in a class)</li> </ul> <pre>11   0 7 6 12   1 4 4 3 13   2 4</pre>	1.5 h	<ul style="list-style-type: none"> <li>• Rulers or measuring tapes</li> </ul>	Q4, 7
7.2.3 Line Graphs SB p. 198 TG p. 271	<b>6-F4 Line Graphs: construct and interpret</b> <ul style="list-style-type: none"> <li>• understand that the purpose of a line graph is to focus on trends implicit in the data (e.g., for temperature change over time)</li> </ul>	1.5 h	<ul style="list-style-type: none"> <li>• Lined paper, grid paper, or Small Grid Paper (BLM)</li> </ul>	Q2, 4
CONNECTIONS: Telling a Story About a Graph (Optional) SB p. 202 TG p. 275	Make a connection between line graphs and the information they represent	30 min	None	N/A

## UNIT 7 PLANNING CHART [Continued]

	Outcomes or Purpose	Suggested Pacing	Materials	Suggested Assessment
<b>7.2.4</b> Coordinate Graphs <b>SB p. 203</b> <b>TG p. 276</b>	<b>6-F5 Coordinates: plotting</b> <ul style="list-style-type: none"> <li>• plot data in all four quadrants</li> <li>• understand that a negative number for the second coordinate indicates that the point is below the horizontal axis</li> <li>• understand that a negative number for the first coordinate indicates that the point is left of the vertical axis</li> <li>• understand that the point at which the axes intersect has coordinates (0, 0) and is known as the origin</li> </ul>	1.5 h	<ul style="list-style-type: none"> <li>• Grid paper or Small Grid Paper (BLM)</li> </ul>	Q1, 3, 4
<b>GAME:</b> Four in a Line (Optional) <b>SB p. 207</b> <b>TG p. 279</b>	Practise coordinate graphing in a game situation	25 min	<ul style="list-style-type: none"> <li>• Grid paper or Small Grid Paper (BLM)</li> </ul>	N/A
<b>Chapter 3 Statistics and Probability</b>				
<b>7.3.1</b> Mean, Median, and Mode <b>SB p. 208</b> <b>TG p. 280</b>	<b>6-F6 Mean, Median, and Mode: concepts</b> <ul style="list-style-type: none"> <li>• understand conceptually               <ul style="list-style-type: none"> <li>- the mean is the average calculated by taking the total amount of the pieces of data and sharing it equally among the pieces of data</li> <li>- the median is another type of average; it is the middle number in an ordered set of data</li> </ul> </li> <li>• understand that the mean and median may be the same or may be different</li> <li>• understand that the mode is a type of average; it shows the data that appear most often</li> </ul>	1 h	None	Q1, 2, 4, 8
<b>7.3.2</b> Theoretical Probability <b>SB p. 211</b> <b>TG p. 282</b>	<b>6-G2 Theoretical Probability: determine</b> <ul style="list-style-type: none"> <li>• understand that theoretical probability is number of favourable outcomes divided by the number of possible outcomes</li> <li>• use fractions, decimals, and percents to describe probabilities</li> <li>• identify events that might be associated with a particular theoretical probability</li> </ul>	1 h	<ul style="list-style-type: none"> <li>• Fraction Circles for Spinners (BLM)</li> </ul>	Q1, 5
<b>UNIT 7 Revision</b> <b>SB p. 214</b> <b>TG p. 285</b>	Review concepts and skills in the unit	2 h	<ul style="list-style-type: none"> <li>• Dice</li> <li>• Grid paper or Small Grid Paper (BLM)</li> <li>• Fraction Circles for Spinners (BLM)</li> </ul>	All questions
<b>UNIT 7 Test</b> <b>TG p. 289</b>	Assess the concepts and skills in the unit	1 h	<ul style="list-style-type: none"> <li>• Grid paper or Small Grid Paper (BLM)</li> </ul>	All questions
<b>UNIT 7 Performance Task</b> <b>TG p. 292</b>	Assess concepts and skills in the unit	1 h	<ul style="list-style-type: none"> <li>• Grid paper or Small Grid Paper (BLM)</li> </ul>	Rubric provided
<b>UNIT 7 Blackline Masters</b> <b>TG p. 296</b>	BLM 1 Fraction Circles for Spinners Small Grid Paper on <b>page 38</b> in UNIT 1			

## Math Background

- When we understand the collection, display, and interpretation of data, and how probability works, we can better interpret many things we read and hear about in our everyday lives, particularly through the media. It is important for students to learn to react thoughtfully to statistics and graphs they read and hear about.
- As students proceed through this unit they will use a variety of mathematical processes, including problem solving, communication, reasoning, representation, visualization, and making connections.

For example:

- Students use problem solving in **question 6** in **lesson 7.2.2**, where they create a stem and leaf plot so that the mean appears in a particular row, in **question 6** in **lesson 7.3.1**, where they determine values that make the median of two sets of data the same, and in **question 5** in **lesson 7.3.2**, where they create events to match probabilities.
- Students use communication in **question 4** in **lesson 7.1.1**, where they communicate about avoiding bias in sampling, in **question 8** in **lesson 7.3.1**, where they discuss why it is reasonable to call a mean, median, or mode an average, and in **question 2** in **lesson 7.3.2**, where they reason about the probability of landing on a particular section of a spinner.
- Students use reasoning in **question 2** in **lesson 7.1.1**, where they think about how to avoid bias in sampling, in **lesson 7.1.2**, where they explore the problem of using too small a sample, in **question 4** in **lesson 7.2.4**, where they decide how to locate a point on a coordinate grid to meet a given condition, and in **question 5** in **lesson 7.3.1**, where they draw conclusions about the median and mean of the ages of people in a family.

- Students consider representation in **question 3** in **lesson 7.2.1**, where they see how a different double bar graph of the same data might lead to different conclusions, in **question 3** in **lesson 7.2.3**, where they use a graph to display information about distance travelled, and in **question 5** in **lesson 7.2.4**, where they use coordinates to describe a picture.
- Students use visualization in **lesson 7.2.1**, where they draw conclusions by looking at a double bar graph, in **lesson 7.2.3**, where they use a graph to describe a trend, and in **question 7** in **lesson 7.2.4**, where they visualize a square from information about only two of its vertices.
- Students make connections in **question 2** in **lesson 7.2.2**, where they relate bar graphs to stem and leaf plots, in **question 5** in **lesson 7.2.2**, where they relate information about multiplying numbers to the form of a stem and leaf plot, and in **question 5** in **lesson 7.2.3**, where they examine a graph that describes the value of the ngultrum.

## Rationale for Teaching Approach

- This unit is divided into three chapters.  
**Chapter 1** focuses on data sampling.  
**Chapter 2** focuses on graphing.  
**Chapter 3** focuses on statistics and probability.
- There is one **Explore** lesson. It lets students experience how important it is to have a large enough sample before drawing conclusions.
- The **Connections** allows students to apply the concepts they have learned about interpreting trends in line graphs and apply them to graphs that describe real-world situations.
- The **Game** provides an opportunity for students to practise coordinate graphing.

## Getting Started

Curriculum Outcomes	Outcome relevance
5 Bar and Double Bar Graphs: construct and interpret 5 Coordinate Graphs: construct and interpret 5 Mean: effect of change in data 5 Describe Probability	Reviewing what students know about graphing, probability, and the mean will support their work in this unit.

Pacing	Materials	Prerequisites
1 h	<ul style="list-style-type: none"> <li>• Dice</li> <li>• 10 counters or small objects</li> <li>• Grid paper or Small Grid Paper (BLM)</li> </ul>	<ul style="list-style-type: none"> <li>• coordinate graphing</li> <li>• creating double bar graphs</li> <li>• calculating a mean</li> <li>• writing a probability as a fraction</li> </ul>

### Main Points to be Raised

#### Use What You Know

- If you use a larger sample size, a probability experiment will give results that are more useful for predicting what will happen in the future.
- A fraction from 0 to 1 can describe an experimental probability. The numerator tells the number of times a particular event occurred and the denominator tells the number of events in the sample.

#### Skills You Will Need

- A double bar graph shows two sets of data on one graph using the same categories. The bars for the same category touch each other; bars for different categories should not be touch.
- On a coordinate grid, you draw two axes at right angles. The first coordinate of a point, called the  $x$ -coordinate, tells how far right it is from the intersection of the axes. The second coordinate of a point, called the  $y$ -coordinate, tells how far up the point is from the intersection of the axes.
- You can calculate the mean of a set of data by adding all the data values and dividing the total by the number of pieces of data. The mean tells what each share would be if the data values were equally shared.
- A fraction from 0 to 1 can describe the expected (theoretical) probability of an event. The numerator tells the number of occurrences of the outcome that is being described; the denominator tells the total number of possible outcomes.

### Use What You Know — Introducing the Unit

- Provide dice and 10 counters to pairs of students. If necessary, some students can play in threes, with one pair competing against one other student. For counters, you can use any small objects, or students can make tally marks on a piece of paper.
- Make sure students understand the Lucky Seven rules. They first choose one player (or pair) to be Player 1 and the other to be Player 2. Player 1 gets a counter only if the sum on the two dice is 5 to 8. Otherwise, Player 2 gets a counter. They play until all 10 counters have been given out.
- Ask students to recall what experimental probability means.

For example, ask this question:

- Suppose that after the first game, Player 1 has 3 counters and Player 2 has 7 counters. Who won the game?

- Based on the result from the first game, what is the probability that Player 2 will win the next game?

(7 out of 10, or  $\frac{7}{10}$ )

- Make sure that students understand they must keep a chart to record the results and that they must make predictions at **part A ii), part A iv), and part C**. Predicting is an important part of the activity.

While you observe students at work, you might ask questions such as the following:

- *Why did Player 2 win that counter?* (The sum was 10.)
- *Why did you predict that it will be a tie?* (In rolls 1 and 2, each of us got a counter.)
- *Why did you decide to change your prediction?* (I thought it was going to be even, but now Player 1 has most of the counters and, even if I win the last 2 counters, Player 1 will still win.)
- *How did you decide what to write as the probability?* (Since Player 1 won 7 times out of 10, the fraction for the probability should be  $\frac{7}{10}$ .)

### Skills You Will Need

- To ensure students have the required skills for this unit, assign these questions. You may wish first to review the meaning of the terms *factor*, *multiple*, *expanded form*, and *standard form*.
- Students can work individually.

### Answers

A. Sample responses:

i)

Roll	Sum	Player 1	Player 2
1	4		√
2	8	√	
3			

ii) Player 2 will win.

iii)

Roll	Sum	Player 1	Player 2
1	4		√
2	8	√	
3	7	√	
4	3		√
5	7	√	
6	9		√
7	10		√
8	5	√	
9			

iv) Yes; I now think it will be a tie.

v)

Roll	Sum	Player 1	Player 2
1	4		√
2	8	√	
3	7	√	
4	3		√
5	7	√	
6	9		√
7	10		√
8	5	√	
9	12		√
10	3		√

- The probability for Player 1 was  $\frac{4}{10}$ . The probability for Player 2 was  $\frac{6}{10}$ .
- My first prediction, in **part A ii)**, was correct.

C. Sample response:

I predict a tie. Out of three games played, Player 1 won one game, Player 2 won one game, and the third game was a tie so it looks like both players have an equal chance of winning.

1.

Homework Time

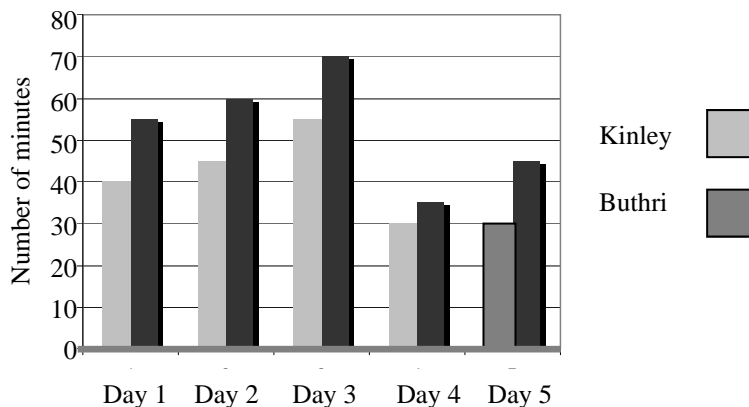

## Answers [Continued]

2. A hexagon (with all right angles)

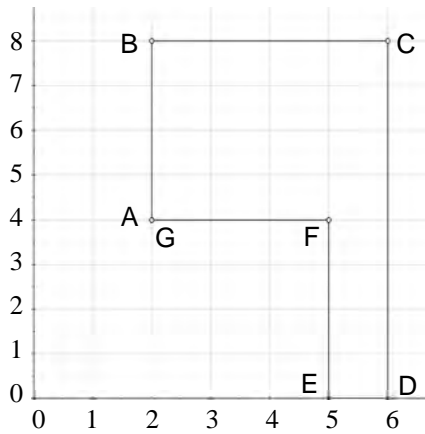

3. a) The  $y$ -coordinate is 1 less than double the  $x$ -coordinate.

b) *Sample response:* (7, 13) and (8, 15)

c) They form a line.

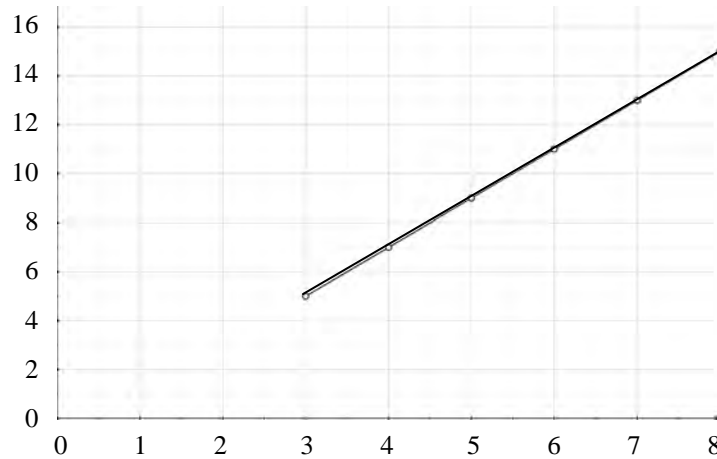

4. a) 10

b) i) The mean increases; [When the total increases, the total divided by 6 also increases.]

ii) The mean decreases; [When the total decreases, the total divided by 6 decreases.]

iii) The mean decreases; [*Sample response:* 20 is higher than the mean, so when I remove it there are not enough data values above the mean to balance the amount below the mean so the mean has to go down.]

5. a)  $\frac{1}{2}$

b)  $\frac{1}{6}$

c)  $\frac{4}{6}$

d)  $\frac{3}{5}$

## Supporting Students

### *Struggling students*

- Some students may need some re-teaching of one of these topics: describing a probability as a fraction, coordinate grid graphs, double bar graphs, and calculating a mean. You may choose to work with small groups of students to help them with one or more of these topics.

### *Enrichment*

- Students may wish to create designs on a coordinate grid that other students can figure out, knowing some of the coordinates.
- Other students may wish to create alternative games like the game in **Use What You Know**, where the points are assigned differently. They can then test to see which games are fair and which are not.

# Chapter 1 Collecting Data

## 7.1.1 Choosing a Sample

Curriculum Outcomes	Outcome relevance
<b>6-F1 Evaluate Data: choose appropriate samples</b> <ul style="list-style-type: none"><li>• consider the issue of sampling (sources of bias and sample size)</li></ul>	Students encounter statistical information all the time. It is important for them to recognize that the samples upon which conclusions are based must be selected thoughtfully.

Pacing	Materials	Prerequisites
40 min	None	None

### Main Points to be Raised

- A sample is part of a population. The population is everyone or everything that might be considered.
- We often choose to survey a sample rather than a whole population because this saves time or money, or because the whole population cannot be reached.
- A good sample represents the population well. It is not biased in favour of only part of the population.
- When you see information about a group, it is important to consider the sample upon which the information was based and to decide whether the sample is biased.

### Try This — Introducing the Lesson

**A.** Allow students to try this alone or with a partner. While you observe students at work, you might ask questions such as the following:

- *Why did you decide not to ask any teachers?* (I wanted to find out the favourites of the students.)
- *How many people would you choose to ask?* (Maybe 20. If I ask too few people, I cannot be sure that the results show the usual choices, but it would take too long to ask too many people.)
- *Why would you not ask only students in your class?* (That is just one age group. Younger students might make different choices, and I want to know about all the students.)

### The Exposition — Presenting the Main Ideas

- Tell students that you are interested in finding out what fraction of the students in Bhutan have travelled outside of the country. Ask why you should not ask only students in Samtse (since they live so close to the border). Help students see that the sample of students you ask should represent the whole population.
- Read through the exposition on **page 187** of the student text with the students.

### Revisiting the Try This

**B.** Students consider an example of bias using the population described in **part A**.

### Using the Examples

- Present the question in the example. Ask students to talk in pairs or small groups about how they would approach the problem. They can then read the solution presented.

### Practising and Applying

#### Teaching points and tips

**Q 1:** Make sure students refer back to the example and that they consider what the population is (every student in the school) before answering the question.

**Q 2:** Encourage students to discuss their answers in pairs.

**Q 4:** Students need to realize that the question could apply not only to voters, but also to those not eligible to vote.

### Common errors

- Some students do not consider what the actual population consists of. Encourage them to write down that information before deciding whether or not a sample is biased.

### Suggested assessment questions from Practising and Applying

<b>Question 1</b>	to see if students can identify whether a sample is biased
<b>Question 2</b>	to see if students can describe how to avoid bias
<b>Question 3</b>	to see if students understand why samples are used

### Answers

<b>A. Sample response:</b> I would ask the students in my class; The students in my class are all in one place, so it would be easy to ask them.	<b>B. Sample response:</b> I would ask students in every class to get students of different ages. I would ask both boys and girls. I would ask people who have tried many kinds of momos as well as those who have tried only one kind.
<b>1. Sample response:</b> <b>a)</b> Biased; [It includes teachers and parents, who are not part of the student population.] <b>b)</b> Might not be biased; [If the list contains a mix of all the students from all classes.] <b>c)</b> Biased; [People who walk might feel differently than people ride to school.]  <b>[2. Sample response:</b> <b>a)</b> I would ask people of different ages. I would ask them on different days of the week — work days and weekends. <b>b)</b> I would ask families who live in rural areas as well as urban areas. I would ask families from every dzongkhag in the country. <b>c)</b> I would ask boys, girls, men, and women. I would not ask only people at an archery contest. <b>d)</b> I would ask people of all ages. I would ask them when they eat breakfast on weekdays, Sundays and holidays.]	<b>[3. Sample response:</b> <b>a)</b> There are too many people in Bhutan to ask all of them. <b>b)</b> It would be a biased sample because Thimphu is a city; people would not have to walk as far because places are close together.]  <b>[4. Sample response:</b> I would ask both people who were still in school and adults. I would ask people with a lot of education and those with little education. I would ask people who had been to other countries and people who had not.]

### Supporting Students

#### Struggling students

- Students need to bring a lot of cultural knowledge to this lesson. This may be a problem for some students. You may need to help them better understand the social situations being discussed or you may have to suggest alternative situations that are more familiar to the students.



## 7.1.2 EXPLORE: Sample Size

Curriculum Outcomes		Outcome relevance
<b>6-G1 Reliability: evaluate</b> <ul style="list-style-type: none"><li>• evaluate sampling results</li><li>• understand that data from larger samples generally produce more reliable probabilities</li></ul>		This essential exploration helps students understand why sample size is important. This will support their current and future work with probability.
Pacing	Materials	Prerequisites
1 h	<ul style="list-style-type: none"><li>• Watches or clocks</li><li>• Dice</li></ul>	<ul style="list-style-type: none"><li>• measuring elapsed time</li></ul>

### Exploration

• Tell students that they will be working through experiments to see how the size of a sample affects the conclusions that are drawn. Depending on the time available, you might let students choose one or two of the experiments, or you might have them complete all three. You might have different groups of students in the class do different experiments and then share what they have learned with the rest of the class. Each experiment is designed to bring out the same idea — a greater sample size allows you to predict future results with more certainty.

For **parts B, E, and H**, have groups of students record their means or percents on the board so that all students can use the data from the whole class (or the part of the class that worked on that experiment).

While you observe students at work, you might ask questions such as the following:

- *How did you calculate the mean?* (I wrote down how many words each of us wrote, added the values, and then divided by 3 since there were 3 of us.)
- *Was your mean or percent a good predictor of the whole class? Were you sure it would be?* (For two of the experiments, it seemed like we got a similar value than other students, but not for the last experiment. I was not sure what would happen until I saw the values on the board.)
- *Do you think now that you could predict how long it would take other Class VI students to write their name 15 times? Explain.* (I think so. I think the 40 of us in this class would be just like other Class VI students.)
- *Did the results from your 4 rolls of the die match what happened for everyone in the class?* (No. I did not roll any 5s so I would have predicted 0 as the percent. But when I look at everyone's results, I see that 5% to 10% is a better prediction.)
- *Why do you think you should use a bigger sample before you draw a conclusion?* (Things might happen once or twice that are not usual, but if you use a big sample, it is more likely that you will see what happens most of the time.)

### Observe and Assess

As students work, notice the following:

- Do students calculate means and percents correctly?
- Do students make reasonable predictions based on their own data?
- Do students recognize that the larger sample provides them with more stable data and why?

### Share and Reflect

After students have had sufficient time to work through the exploration, discuss questions such as these.

- *How big does a sample need to be before you can trust that it safe to make predictions based on the sample?*
- *How many times would you roll a die before you predict the percent the time a 5 will be rolled?*
- *Do you think you can better predict of how long it takes to write a name 2 times or how long it takes to write a name 15 times? Explain.*

## Answers

**A. Sample responses:**

i) 15 words

ii) 17 words; Our numbers were 15, 17, and 18.

I chose 17 because it was in the middle.

iii) 17 words

**B. Sample response:** 21.2 words

**C. Sample response:**

No; my prediction was low.

**D. Sample response:**

i) 34 seconds

ii) 31 seconds; Our numbers were 34, 28, and 30.

I chose 31.

iii) 31 seconds

**E. Sample response:** 31 seconds

**F. Sample response:**

Yes; The mean for the class was the same as my prediction.

**G. Sample response:**

i) The percent for 5 was 25%.

Sum	Number of times
4	1
8	1
7	1
5	1

ii) 25% of the time 5 will be rolled.

**H. Sample response:**

10% of the time 5 was rolled.

Sum	Number of times
2	1
3	3
4	3
5	4
6	7
7	6
8	5
9	4
10	3
11	2
12	2

**I. Sample response:**

No; My prediction was way too high.

**J. Sample response:**

Not usually; It was only a good prediction one time out of three experiments.

## Supporting Students

### *Struggling students*

- Some students have difficulty seeing why their limited data is not as good as a greater amount of data. If the data sources are different, they might view the larger set of data as the less reliable set because they have more faith in their own data. You may need to have them repeat the experiment several times so that they see that the larger set of data is closer than the smaller set of data to what happens the next time.

### *Enrichment*

- Students may wish to design other experiments that they can use to test the appropriate sample size for prediction.

For example, they might do an experiment to predict how many seconds people wait before they think one minute has passed after a given start time.

## Chapter 2 Graphing Data

### 7.2.1 Double Bar Graphs with Intervals

Curriculum Outcomes		Outcome relevance
<b>6-F2 Bar and Double Bar Graphs: construct and interpret</b> <ul style="list-style-type: none"><li>• construct and interpret bar graphs and double bar graphs using intervals</li></ul>		The data set we wish to show often has so many possible values that we need to group values into intervals to display it in a way that makes it easy to interpret. Students need to gain experience in choosing those intervals and in using the choice to graph correctly.
Pacing	Materials	Prerequisites
1.5 h	<ul style="list-style-type: none"><li>• Watch or stopwatch</li><li>• Lined paper, grid paper, or Small Grid Paper (BLM)</li></ul>	<ul style="list-style-type: none"><li>• drawing a bar graph using a scale</li></ul>

#### Main Points to be Raised

- A double bar graph shows two sets of data that use the same categories at the same time.
- When you interpret a double bar graph, you can compare values within one set of data, but you can also compare the two sets of data.
- One way to create a bar graph or a double bar graph is to create intervals that each includes more than one response.

For example, rather than showing how many students are 150 cm, how many are 151 cm, how many are 152 cm, and so on, you might show the people who are 150 cm to 155 cm, 155 cm to 160 cm, and so on, so that there are fewer bars to deal with.

- You can select intervals in many ways. You might consider the highest and lowest pieces of data and then divide the range into a certain number of intervals or you might choose intervals that you find easy to work with. Intervals are usually of a similar width, even if they are not exactly the same width.

For example, if data values range from 0 to 50, the intervals might be groups of 5, groups of 10, or groups of 12 (with the last interval going to 50 rather than to 48).

#### Try This — Introducing the Lesson

**A.** Allow students to try this alone. You will need to record on the board the different numbers that students count. While you observe students at work, you might ask questions such as the following:

- *Do you think you will say more numbers counting up, counting down, or will it be about the same?* (It is easier to count forward, so I think I will say more numbers counting up from 1.)
- *How many different values are there in the class for counting up?* (People said 13 different numbers.)
- *How many different values are there in the class for counting down?* (People said 18 different numbers.)
- *How could you make a graph of the counting forward numbers?* (I could have a bar for each number that people said, count how many people said that number, and then graph it.)
- *Could you graph both sets of information on one graph?* (I could make a double bar graph to do that. For some numbers there would be only one bar, since some people said it for counting down but no-one said it for counting up.)

## The Exposition — Presenting the Main Ideas

- Have students look at the double bar graph on **page 191** of the student text. Ask them to indicate some of the things that the bar graph shows. Make sure they recall how double bar graphs are created and in what situations they are used.
- Work through the exposition on **page 192** with the students. Talk about the fact that the categories of data are numerical (i.e., the number of calls is a number) and so it makes sense to have categories like 0 to 4 calls, 5 to 9 calls, and so on. This approach would not make sense with, for example, the data about colours, since even though blue and orange could be combined into one category as blue or orange, there are not really any intervals.
- Make sure students understand how the data was graphed by counting the number of pieces of data in each category to make sure the graph is correct. Point out that the interval sizes are equal.
- Ask the students to re-create a double bar graph using different categories, e.g., 0 to 5 calls, 6 to 11 calls, 12 to 17 calls, to see that this arrangement also works.

## Revisiting the Try This

**B.** Students choose intervals and practise creating a double bar graph with intervals using the data from **part A**. They also consider why such a graph is appropriate in this situation.

## Using the Examples

- Have pairs of students work through the example together. They can support each other as they seek to understand the thinking in the student text.

## Practising and Applying

### Teaching points and tips

**Q 1:** This question is designed to focus students on interpreting a graph rather than on creating it.

**Q 3:** Students need to notice that intervals of size 2 were used in the example, so they need to choose a different size interval.

**Q 5:** You may need to remind students of the meaning of the term *scale*. That is, each unit height of the bar represents more than one person or object.

### Common errors

- Students may have difficulty creating intervals that include all the data but do not overlap.

For example, if they make intervals like 0 to 3, 3 to 6, and so on, they may not deal correctly with the responses that are exactly 3. Help them by showing how you could make the intervals 0 to 3, 4 to 7, and so on, or how you could just decide that an item that is 3 always goes in the higher interval (as is the case with histograms).

### Suggested assessment questions from Practising and Applying

<b>Question 2</b>	to see if students can create a double bar graph using intervals with their own data
<b>Question 3</b>	to see if students can compare graphs that show the same data, but with different interval sizes
<b>Question 4</b>	to see if students can create and interpret a double bar graph from provided data

## Answers

**A. Sample responses:**  
i) 55                      ii) 39

**B. Sample response:**  
We got 18 different numbers for counting up and 15 different numbers for counting down, so it would take a lot of bars.

**C. i) Sample response:**

It would mean that I could draw fewer bars.

**ii)**

**Counting Up and Down**

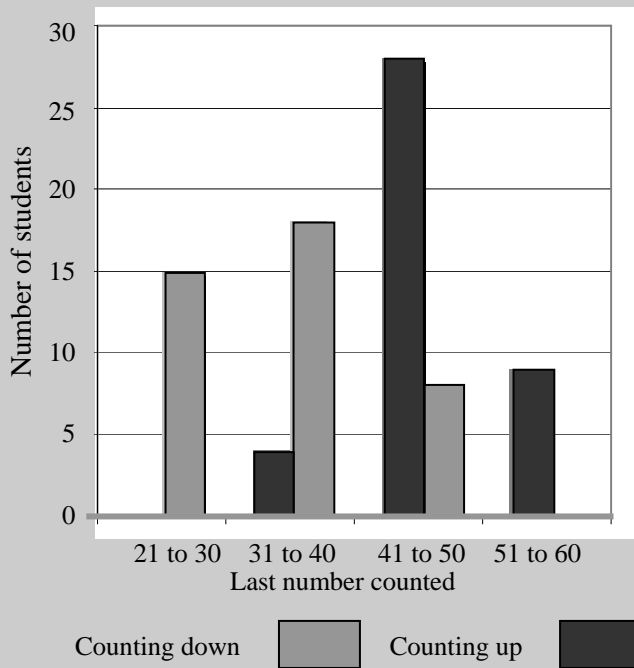

**iii)** I used an interval size of 10 so I would not have too many bars.

**iv)** I used a scale of 5 so my bars would not be taller than 6 units

**1. Sample response:**

It is more likely to get a high number using the sum rather than the difference.

**2. Sample responses:**

**a)**

**Dice Sums and Differences**

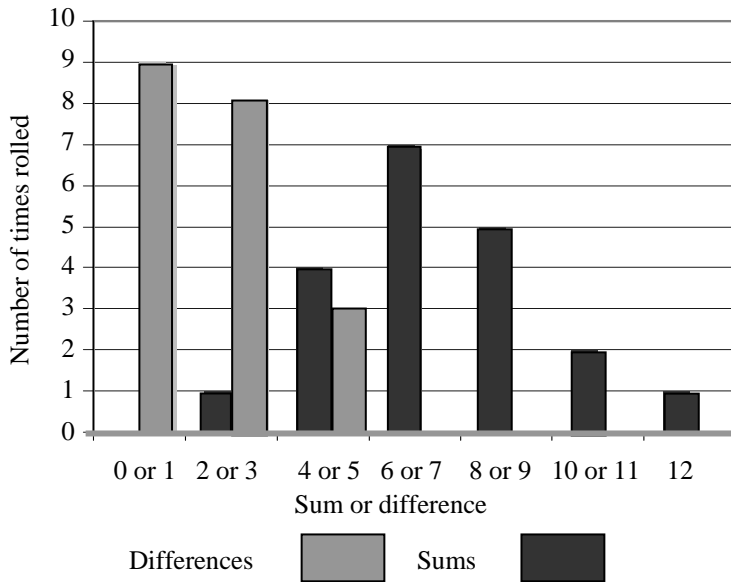

**b)** My graph had a shape similar to the original graph and the same things are true about it. But the actual values were not always the same. For example, I only got a difference of 0 or 1 nine times, not ten times.

**Answers [Continued]**

**3. Sample responses:**

a)

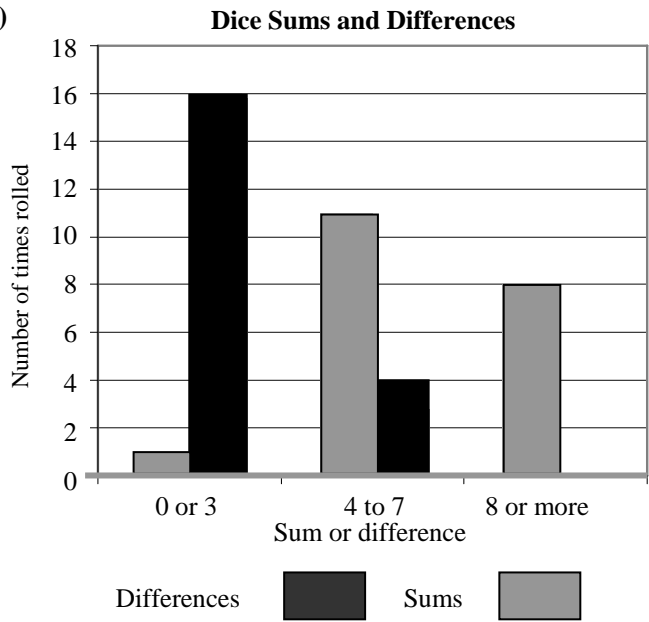

b) It shows some different things; [It does not show, for example, that a sum of 0 or 1 never happens. The other graph showed that.]

**4. Sample responses:**

a)

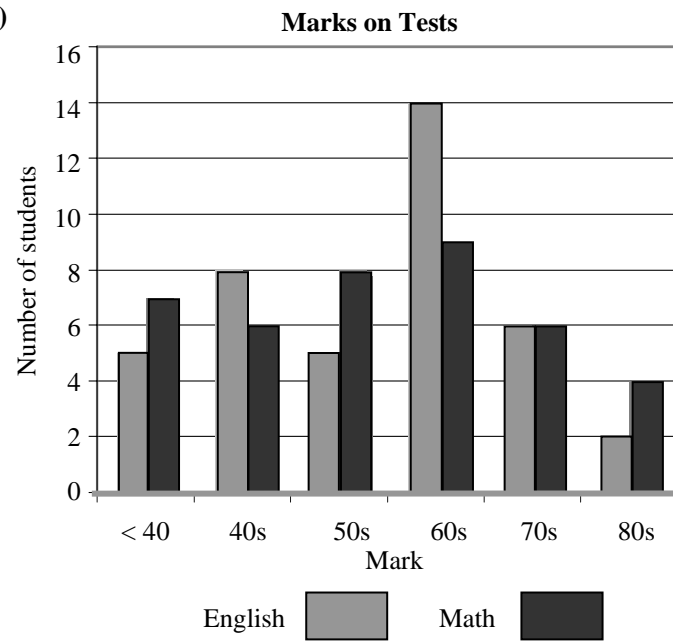

b) The graph shows that for both subjects, many students received marks in the 60s. It also shows that in the 80s there were more math marks than English marks.

**[5. Sample response:**

If I use intervals, there is probably a higher number of data values in each interval. I would use a scale so that the bars are not too high.]

**Supporting Students**

**Struggling students**

- You may suggest an interval size for **question 3** rather than asking students to decide themselves.

**Enrichment**

- Students might build on **question 3** by trying many different interval sizes to see how the graph is affected by the choice of interval.

## 7.2.2 Stem and Leaf Plots

Curriculum Outcomes	Outcome relevance
<b>6-F3 Stem and Leaf Plots: grouping and displaying data</b> <ul style="list-style-type: none"> <li>construct to display grouped numerical data (e.g., heights of students in a class)</li> </ul> <pre> 11   0 7 6 12   1 4 4 3 13   2 4                     </pre>	Students come to see that different organizations of data allow for more or less insight into the data. A stem and leaf plot allows the user not only to see data organized into intervals, but also to see each piece of data individually. For this reason, a stem and leaf plot is more powerful than a bar graph.

Pacing	Materials	Prerequisites
1.5 h	<ul style="list-style-type: none"> <li>Rulers or measuring tapes</li> </ul>	None

### Main Points to be Raised

- A stem and leaf plot organizes data into intervals based on place value.

For example, if the tens digit is the stem and the ones digits are leaves, each row of the plot shows an interval of 10.

- Stems can be single digits like the tens digit or the hundreds digit, or they can be a group of digits (e.g., the hundreds and tens together). Leaves can be one or more digits, depending on what is used for the stem.

For example, if the stem is a hundreds digit, a leaf is the tens and ones digits together.

- You list the leaves for a particular stem in order from least to greatest. The spacing in each row should be the same.

- A stem and leaf plot automatically shows a bar graph if the numbers are spaced evenly in each row.

- A stem and leaf plot provides more information than a bar graph since you not only know how many pieces of data are in each category, but can also see what those data values are.

### Try This — Introducing the Lesson

**A.** Help students collect data about the height of each student in the class by allowing pairs of students to measure each other's heights. Record the data from each pair on the board. Allow students to try **part ii**) alone or with a partner. While you observe students at work, you might ask questions such as the following:

- How might you use a bar graph?* (I would organize the information into intervals and then draw a bar graph using 5 cm intervals.)
- How might you use a pictograph?* (I would organize the information into intervals and then let a figure represent 2 students. I would count how many students are in each category and divide by 2 to figure out how many figures to draw for that category.)
- Which graph do you think shows the information in a better way?* (I think the pictograph is better because the symbols help you see right away that the graph is about people.)

### The Exposition — Presenting the Main Ideas

- Have students look at the first set of data on **page 195** of the student text. Ask them to organize the data into the intervals 0 – 9, 10 – 19, 20 – 29, and so on, and then to create a horizontal bar graph of the grouped data.
- Allow time for students to ask any questions they might have.

### Revisiting the Try This

**B.** Students have a first opportunity to create a stem and leaf plot using the data from **part A**. You can observe whether they have any difficulties with this before you assign any more work.

## Using the Examples

- Have students read through the example. Suggest that they count the number of leaves and then count the number of pieces of data to make sure that no data values were overlooked or counted twice.

## Practising and Applying

### Teaching points and tips

**Q 1:** The purpose of this question is to make sure students can interpret a given stem and leaf plot correctly by translating the stems and leaves into the related numerical values.

**Q 2:** This question asks students to use the same intervals of 10 as the stem and leaf plot to create the bar graph. You could also discuss with students how, since they have all the data values, they could choose other intervals if they wished. In **part b**), students are exposed to 2-digit stems that represent intervals of 10; this is something they did not see in the exposition or the example.

**Q 3:** Students should start at 0 and count by 4s to list the multiples of 4. The purpose of **part b**) is to make the link to division. Since  $10 \div 4 = 2\frac{1}{2}$ , half of the intervals of 10 will include 2 multiples of 4 and half of the intervals will include 3 multiples of 4.

**Q 5:** Some students will have difficulty predicting what the plot will look like; they will have to carry out the experiment and plot the data. Other students will realize that very often it is two small numbers being multiplied, so there will be many more values in the 0 to 9 interval than in the other intervals.

**Q 6: Part a)** is accessible to any student who can calculate a mean. **Part b)** is an extension and is not appropriate for struggling students.

**Q 7:** You may wish to use a class discussion to handle this question. Students will have had a number of experiences going from a stem and leaf plot to a bar graph. Here they see that they cannot go the other way, from a bar graph to a stem and leaf plot, since the bar graph does not reveal the individual pieces of data.

### Common errors

- Many students forget to put the data values in order when they write the leaves for each stem. At this point, it may be difficult for them to see why it matters. Tell them that for now you are simply asking them to do this, but that eventually they will learn why it is useful (for example, for finding the median and mode in a set of data).
- Some students forget to write a repeated piece of data as many times as is necessary.

For example, if the number 22 appears four times in a set of data, they must include four leaves of 2 beside the stem of 2.

### Suggested assessment questions from Practising and Applying

<b>Question 4</b>	to see if students can relate a stem and leaf plot to a bar graph showing the same data and compare the two displays
<b>Question 7</b>	to see if students recognize why a stem and leaf plot is like a bar graph, but is a more powerful graphical display

## Answers

### A. i) and ii) Sample responses:

I could put the data into intervals and make a bar graph.

I could use a double bar graph and compare boys and girls if the data values were collected separately for each.

148	138	149	140	142	150	143	136	141	142
153	145	141	148	135	142	140	151	139	146
152	151	153	144	145	136	149	137	142	150
142	148	136	138	140	149	141	142	145	141



**Heights in Our Class**

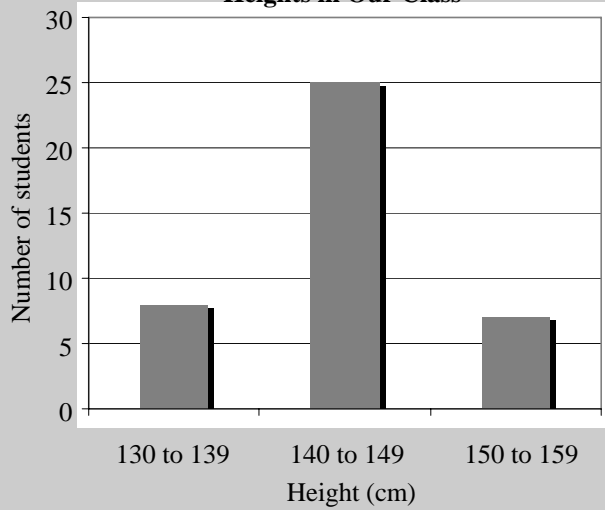

**B. Sample response:**

13	5	6	6	6	7	8	8	9																
14	0	0	0	1	1	1	1	2	2	2	2	2	3	4	5	5	5	6	8	8	8	9	9	9
15	0	0	1	1	2	3	3																	

**1.** 7, 8, 8, 9, 9, 21, 21, 22, 23, 23, 26, 30, 30, 35, 38

**2. a)**

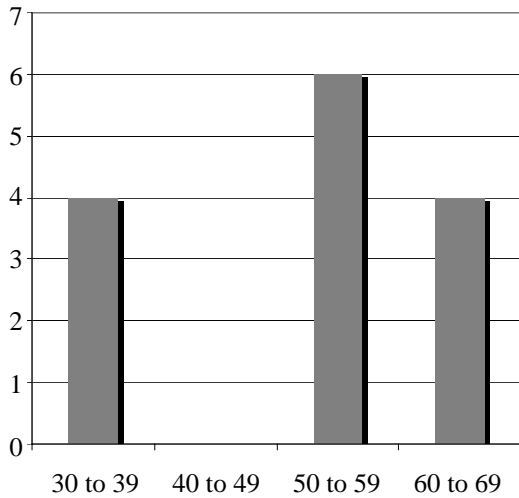

**b)**

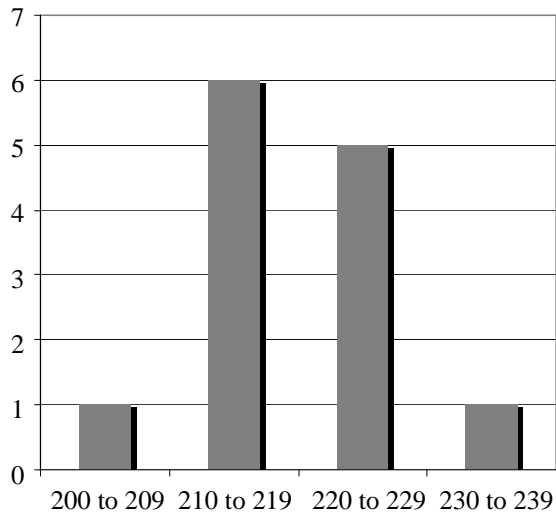

**c)**

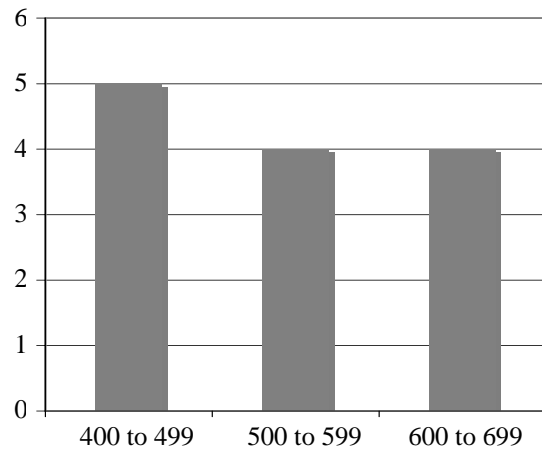

**3. a)**

0	0	4	8
1	2	6	
2	0	4	8
3	2	6	
4	0	4	8
5	2	6	
6	0	4	8

**b) Sample response:**

There are always either 2 or 3 multiples of 4 in every group of 10 numbers.

**Answers [Continued]**

**4. a)**

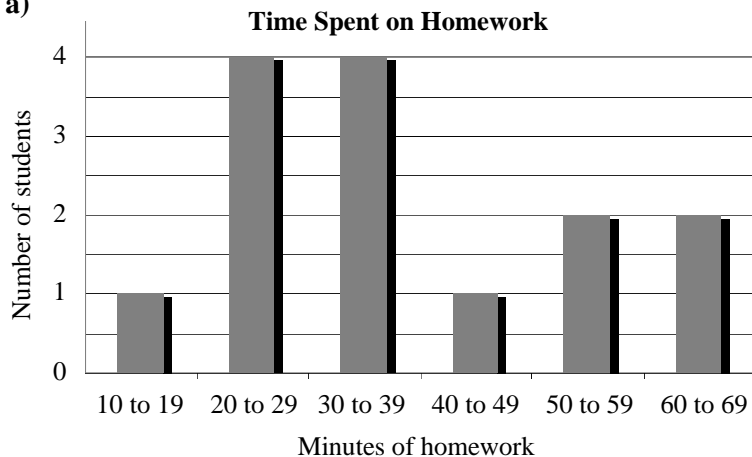

**b) Sample response:**

Both graphs show the same information but the stem and leaf plot also includes the data values. For example, both graphs show that four students spent between 20 and 29 minutes on homework but the stem and leaf plot also shows that one student spent 20 minutes and three students spent 25 minutes.

**5. Sample responses:**

**a)** I predict a plot with a lot of numbers in the 0 to 9 and the 10 to 19 intervals and fewer numbers in the other rows; [When I roll dice the numbers only go to 6, so lots of times I will be multiplying numbers less than 3 and those products are less than 10. It would be hard to get a really high amount — I would have to roll two very high numbers.]

**b)**

3, 3	5, 3	4, 5	1, 2	6, 4	2, 5	5, 6	3, 2	6, 6	1, 1	4, 4	3, 5	2, 5	5, 6	6, 2
5, 4	2, 1	3, 5	4, 3	1, 5	5, 1	5, 2	2, 2	3, 1	5, 3	1, 3	6, 4	6, 3	4, 1	1, 4

0	1	2	2	3	3	4	4	4	5	5	6	9
1	0	0	0	2	2	5	5	5	5	6	8	
2	0	0	4	4								
3	0	0	6									

My prediction was good.

**6. a)** In the second row since the mean is 225.

**b) Sample response:**

The mean is 19, which is in the first row.

1	7	7	7	7	7	8	9
2							
3	0						

[7. If you have a stem and leaf plot, you have all the data values you need for making a bar graph. If you have a bar graph that uses intervals, you do not know what the exact values are, so you cannot make a stem and leaf plot.]

## Supporting Students

### Struggling students

• Struggling students may have difficulty with **questions 5 a) and 6 b)**. You may choose not to assign these questions to struggling students. For **question 5 b)**, rather than testing their prediction, they can simply carry out the experiment and record their results.

### Enrichment

• Some students might enjoy creating and solving questions like **questions 5 or 6**.

For example, they might predict the stem and leaf plot that would result from spinning a spinner with numbers from 1 to 4 twice, doubling both numbers and then adding them. They can then test their prediction. Or, they might create a stem and leaf plot with at least three rows where the mean is in the last row.

## 7.2.3 Line Graphs

Curriculum Outcomes		Outcome relevance
<b>6-F4 Line Graphs: construct and interpret</b> <ul style="list-style-type: none"> <li>understand that the purpose of a line graph is to focus on trends implicit in the data (e.g., for temperature change over time)</li> </ul>		Line graphs are often used in the media to describe trends. Introducing students to this type of graph broadens their understanding of how graphs can be used to describe data.
Pacing	Materials	Prerequisites
1.5 h	<ul style="list-style-type: none"> <li>Lined paper, grid paper, or Small Grid Paper (BLM)</li> </ul>	<ul style="list-style-type: none"> <li>plotting on a coordinate grid</li> </ul>

### Main Points to be Raised

- A line graph is used to show how a value changes over time. It helps people see trends, for example, whether values are increasing, decreasing, and so on.
- Points on a line graph are plotted on a coordinate type grid and connected to show the trend.
- Line graphs might be used to show temperature changes, price changes, population changes, and so on.

### Try This — Introducing the Lesson

**A.** Allow students to try this alone or with a partner. While you observe students at work, you might ask questions such as the following:

- How did you organize your bar graph?* (I made 12 bars, one for each month.)
- How could you have organized the bar graph using intervals?* (I could have shown how many months had average temperatures in different intervals, for example, 11 – 15, 16 – 20, 21 – 25, and so on.)
- What would you use for the stems in a stem and leaf plot? Why?* (Since the numbers have two digits, I would use the tens digit for the stems and the ones digits for the leaves.)
- Why did you choose a stem and leaf plot?* (That way I could show the actual values.)

### The Exposition — Presenting the Main Ideas

- If you can find a line graph that appeared recently in media newspaper or a magazine, you may wish to show it to students to start the discussion about line graphs. If not, you might have students look at the line graph on **page 199** of the student text. Ask them to describe what they see. Then you can go back to the chart of data upon which the graph is based that appears on **page 198**. Students can see that the values were plotted on a grid in order from the first point in time (January at 1, 4) to the last point in time (December at 12, 2). Point out how this allows you to visualize how the precipitation changes during the course of a year more easily than if a bar graph had been created to show the different amounts of precipitation for different months.
- Discuss the fact that time is usually displayed on the horizontal axis and the value being examined is usually on the vertical axis, although this is not required. When time is on the horizontal axis, it is easier to see trends over time.
- Have students discuss why a scale was used (since some values are quite high, using a scale keeps the height of the points to a reasonable limit).
- Discuss with the students the last part of the exposition about other typical contexts for line graphs.

### Revisiting the Try This

**B.** This question gives students experience in seeing what kind of information is better transmitted with a line graph than with a bar graph.

### Using the Examples

- Work through the example with the students. You may need to help them interpret the graph.

For example, they need to understand that at the start (0 minutes) there was no water but after 5 minutes there were 10 L of water. Then, after 7 minutes, there was no water again.

## Practising and Applying

### Teaching points and tips

**Q 1:** Some students might benefit from making a chart that describes the information that is plotted.

For example, on Monday the plant was 5 mm high, on Tuesday it was 15 mm high, and so on.

**Q 2:** Students are asked to interpret a graph, but are given some choices about what they might say to help them understand what is expected.

**Q 3:** Students might begin by creating a chart.

**Q 4:** This question is designed so students can see how the appearance of the graph relates to the pattern of data change.

**Q 5:** If students do not know what to say, encourage them to talk about how the number of ngultrums for each dollar increases or decreases.

**Q 6:** Students should see how it is easier to describe change in data with a line graph than with a chart or another type of graph.

### Suggested assessment questions from Practising and Applying

<b>Question 2</b>	to see if students can select an appropriate description of a trend shown in a line graph
<b>Question 4</b>	to see if students can create and interpret a line graph

## Answers

### A. Sample response:

1	5	6					
2	0	1	2	4	7	8	
3	0	1	1	2			

### B. i)

Monthly High Temperatures in Punakha

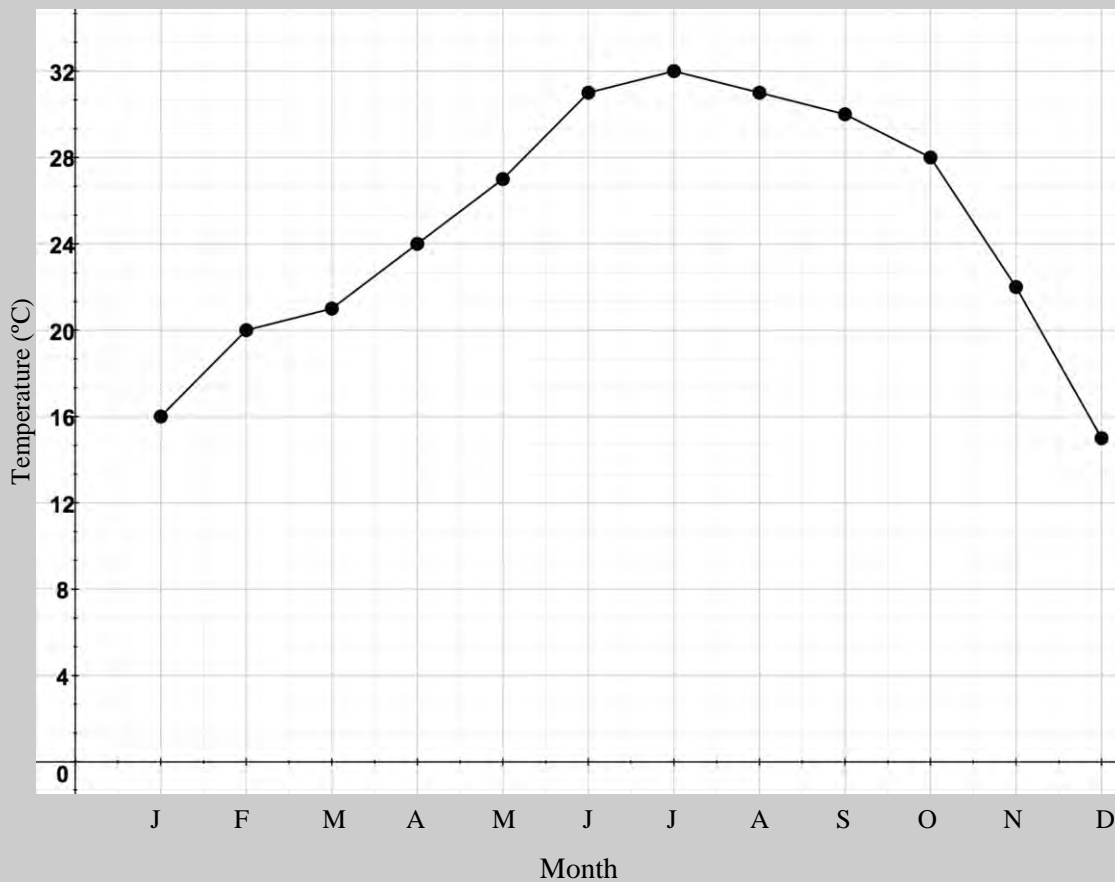

### ii) Sample response:

The stem and leaf plot does a better job of showing you the actual temperature values.

The line graph does a better job of showing how the temperature changes over the year.

**1. Sample response:**

The plant grows a little bit every day.

The growth was a bit faster from Monday to Wednesday than from Wednesday to Friday.

**2. C**

**3.**

**Distance Travelled by Number of Pedal Turns**

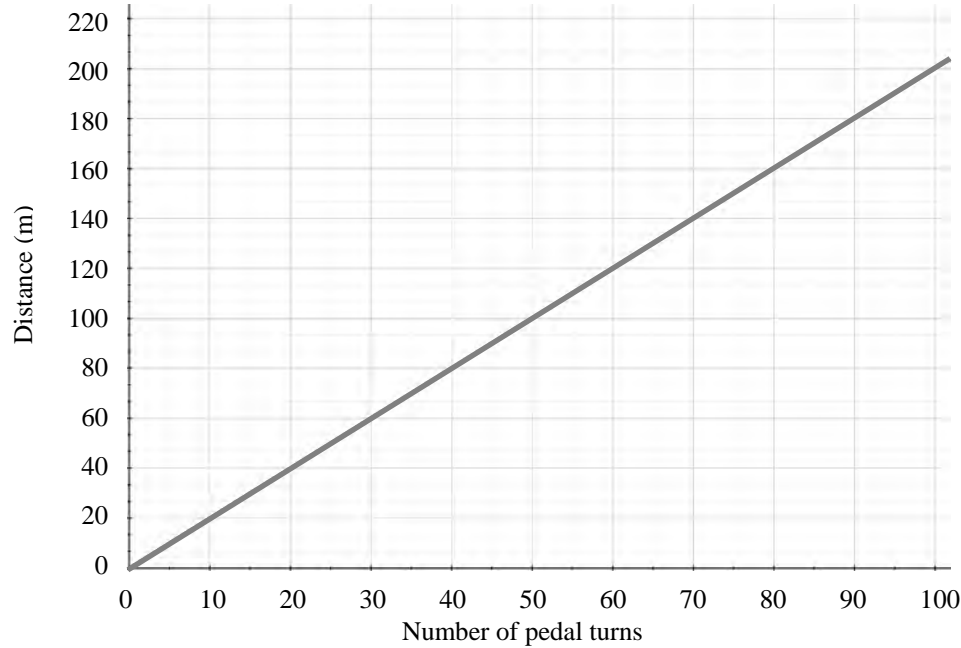

**4. a)**

**Temperature Over a Week**

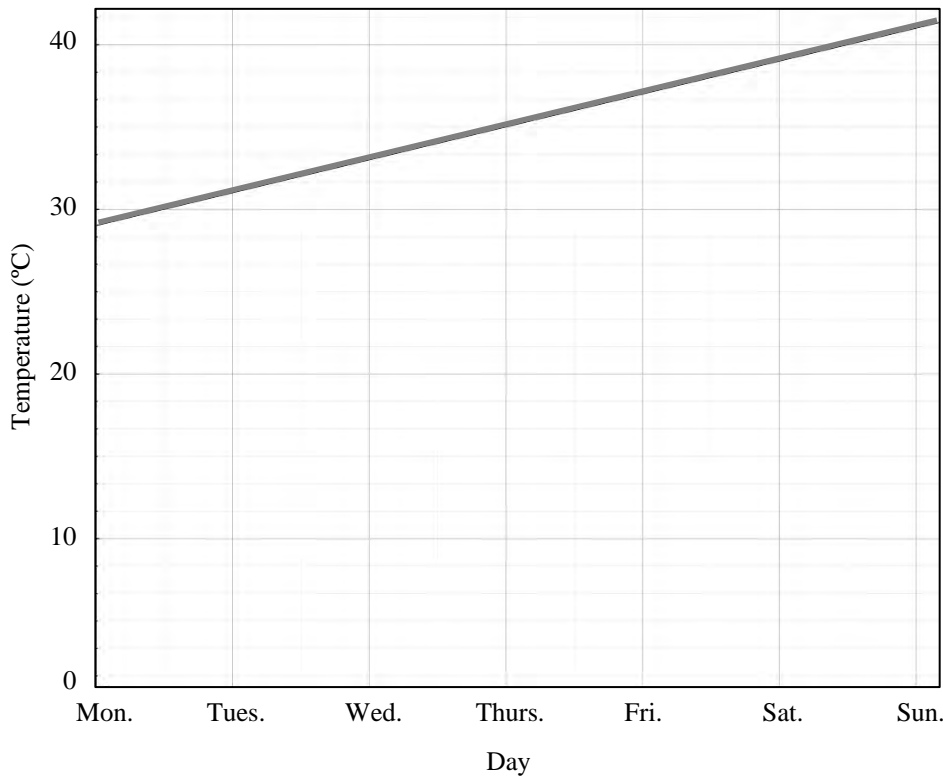

**b) Sample response:**

The temperature increased at a steady rate.

**c) Sample response:**

The temperature would have increased faster so the line would be steeper.

## Answers [Continued]

### 5. *Sample response:*

The graph shows that the number of ngultrums per dollar increased for a while, then it went down, then it stayed steady, and then it went down again.

### 6. a)

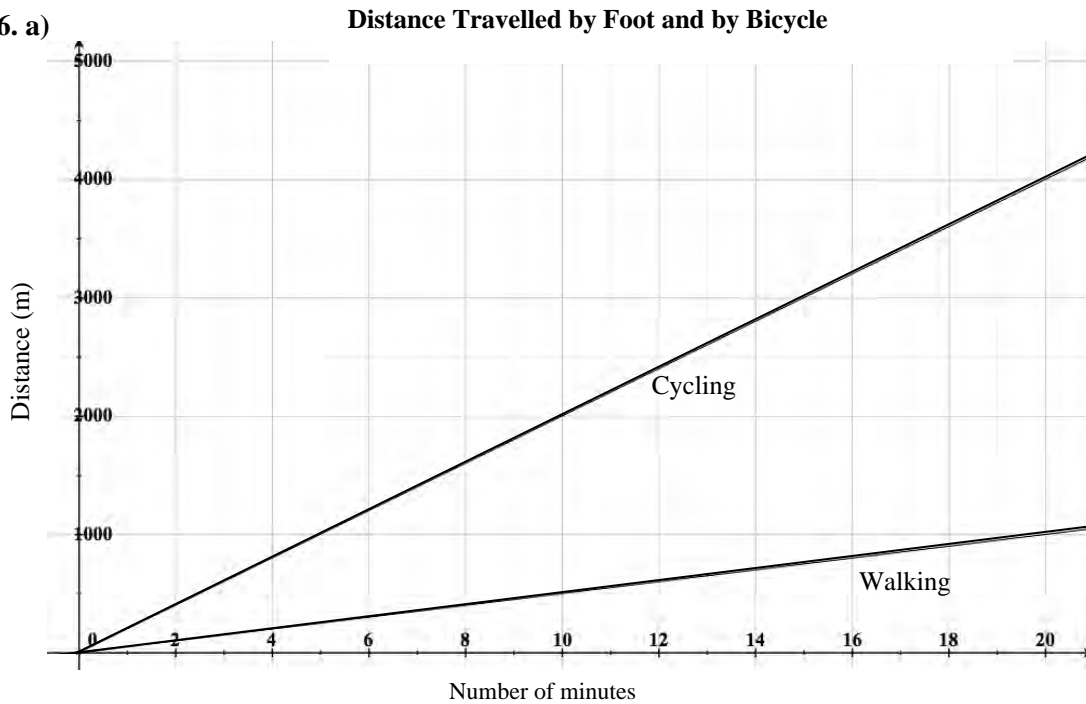

### b) *Sample response:*

The difference between the distances becomes greater and greater as more time passes.

### [7. *Sample response:*

A line graph lets you see the same information at different times. The times to the right are always after the times to the left, so you can see the trend.]

## Supporting Students

### *Struggling students*

- Struggling students may have difficulty coming up with language to describe the trends in a graph. You may need to support these students by giving them choices about what one might say. They could select from those choices.

### *Enrichment*

- Students might look for examples of line graphs in the media and report to other students about what they find.

## CONNECTIONS: Telling a Story about a Graph

- This connection shows students how a line graph can tell a story. The graphs shown on **page 202** of the student text can be translated into words that describe two treks.
- Make sure students understand how to interpret the graphs by looking with them at the left graph. Ask how they know that the graph shows that at 0 minutes, the climb had not yet begun (the height is 0 at time 0). Make sure they understand that when the graph rises to the right, the height is increasing with time.
- Students should come to understand that a flat section could describe a resting time but it also could describe a person walking on a flat section; in both cases, the height of the trekker is not changing.

### Answers

1. The graph on the left matches Mindu's description; the graph on the right describes Karma's description.

[2. When you are resting or when you are walking on a flat section, the height does not change.]

3. *Sample response:*

I started walking up a small hill and did not rest going up the hill.

I started to come down and then walked on a flat section for a little while.

Then I climbed a bigger hill, stopped at the top for a rest, and walked back down without resting.

## 7.2.4 Coordinate Graphs

Curriculum Outcomes	Outcome relevance
<b>6-F5 Coordinates: plotting</b> <ul style="list-style-type: none"> <li>• plot data in all four quadrants</li> <li>• understand that a negative number for the second coordinate indicates that the point is below the horizontal axis</li> <li>• understand that a negative number for the first coordinate indicates that the point is left of the vertical axis</li> <li>• understand that the point at which the axes intersect has coordinates (0, 0) and is known as the origin</li> </ul>	Coordinate graphs are an essential part of higher level mathematics. Students need to become familiar with their use. Although they met coordinate graphing in Class V, here they extend their knowledge to be able to use negative coordinates.

Pacing	Materials	Prerequisites
1.5 h	<ul style="list-style-type: none"> <li>• Grid paper or Small Grid Paper (BLM)</li> </ul>	<ul style="list-style-type: none"> <li>• plotting on a coordinate grid with positive coordinates (Quadrant I)</li> </ul>

### Main Points to be Raised

- A coordinate graph has a horizontal  $x$ -axis and a vertical  $y$ -axis. The  $x$ -coordinate tells how far right or left a point is from the origin (0, 0) and the  $y$ -coordinate tells how far up or down a point is from the origin.
- If the  $x$ -coordinate is positive, the point is right of (0, 0); if it is negative, a point is left of the origin.
- If the  $y$ -coordinate is positive, the point is up from (0, 0); if it is negative, the point is down from the origin.
- A full coordinate grid has four quadrants. Each quadrant is one fourth of the whole graph.
- In Quadrant I, both coordinates are positive. In Quadrant III, both coordinates are negative. In Quadrant II, the  $x$ -coordinate is negative and the  $y$ -coordinate is positive. In Quadrant IV, the  $x$ -coordinate is positive and the  $y$ -coordinate is negative.

### Try This — Introducing the Lesson

**A.** Allow students to try this alone or with a partner. You may need to remind students to plot the first number as the distance right and the second number as the distance up. While you observe students at work, you might ask questions such as the following:

- *How did you decide where to place (5, 3)?* (I had to go 5 spaces to the right and 3 spaces up from the origin.)
- *How do you move from (7, 5) to (6, 4)?* (You go to the left and down.)
- *If you joined the points, what shape would you get?* (A line)
- *If you look at each coordinate pair, how are the numbers related?* (They are always 2 apart.)

### The Exposition — Presenting the Main Ideas

- Draw a coordinate grid on the board and ask students where to plot several points, e.g., (3, 5), (5, 3), and (2, 4).
- Ask for their ideas about where to plot (–1, 3) and see if they independently figure out that they would go to the left of the vertical axis rather than the right. If they do not come up with this idea, you can propose it and discuss with them why it makes sense.
- Introduce a grid showing all four quadrants. Ask students to name a point they think is located in each of the quadrants.
- Have students look at the summary on **page 204** of the student text to see the signs for coordinates in the four quadrants.

### Revisiting the Try This

**B.** Students extend their graph from **part A** to include negative coordinates. In this way, they practise plotting with negative values.



## Using the Examples

- Provide grid paper to the students. Present the question from **example 1** on the board and ask students to complete the task. They can compare their results with the solution in the text.
- Then present the question in **example 2** and see how students approach the situation. They can compare their thinking with the solution in the text so they can see how both the placement of the parallelogram and its size are relevant. Although the parallelogram does not need to have any horizontal sides, it may be easier for students if they make two of the sides horizontal. Students will need to use the idea that the opposite sides of a parallelogram are equal in length to solve the problem.

## Practising and Applying

### Teaching points and tips

**Q 1:** Before students begin, you might ask them which point will have two negative coordinates. You might also want to point out that if either coordinate is 0, the point must lie on one of the axes.

**Q 3:** This question, like **example 2**, connects properties of certain shapes with their coordinates.

**Q 4 a):** Students might interpret the word “close” in different ways. There is no one correct interpretation. As long as the student’s ideas make sense, allow for some variation.

**Q 4 b):** Students might have difficulty deciding whether a point is more than 6 units away, since the distance could be on a diagonal. For example, they could go 6 units to the left and then up as much as they want; the distance to the origin must be more than 6 because the horizontal distance is already 6.

**Q 9:** Students could measure with a ruler or they might estimate.

**Q 10:** This question might best be handled as a class discussion. Its purpose is to make sure students understand that each point on a plane is associated with one coordinate pair.

### Common errors

- Some students confuse which coordinate describes left or right and which describes up or down. You will need to keep reminding students that the first coordinate describes the left or right direction (so the other coordinate must describe the up or down direction).

### Suggested assessment questions from Practising and Applying

<b>Question 1</b>	to see if students can name points in the four quadrants
<b>Question 3</b>	to see if students can plot given points
<b>Question 4</b>	to see if students can name a point to fit a particular description

## Answers

**A. i)**

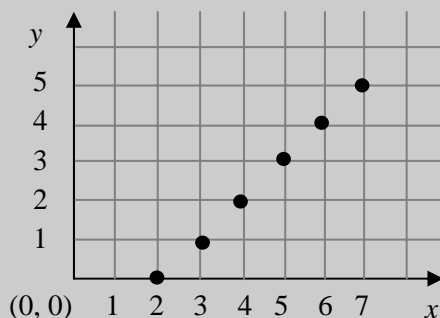

**ii) Sample response:**  
The points are in a line.

**B. i) Quadrant IV and then Quadrant III**

**ii) Sample response:**  
(1, -1), (0, -2), and (-1, -3)

1. A(-4, 6)    B(-2, -1)    C(0, -3)    D(4, -2)

2.

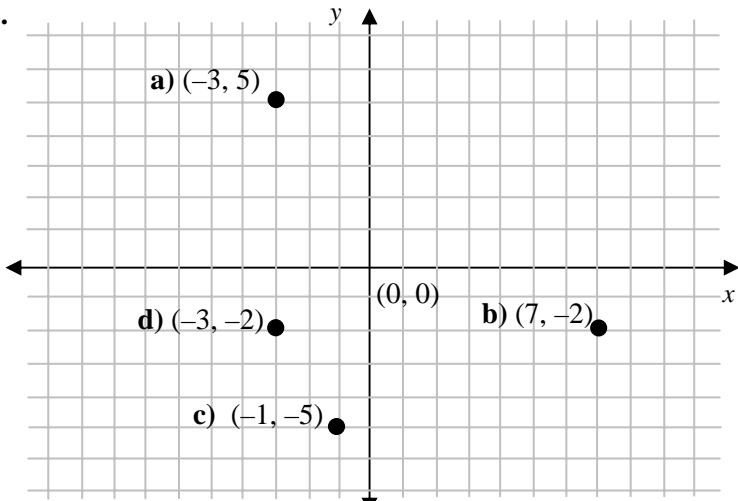

3.

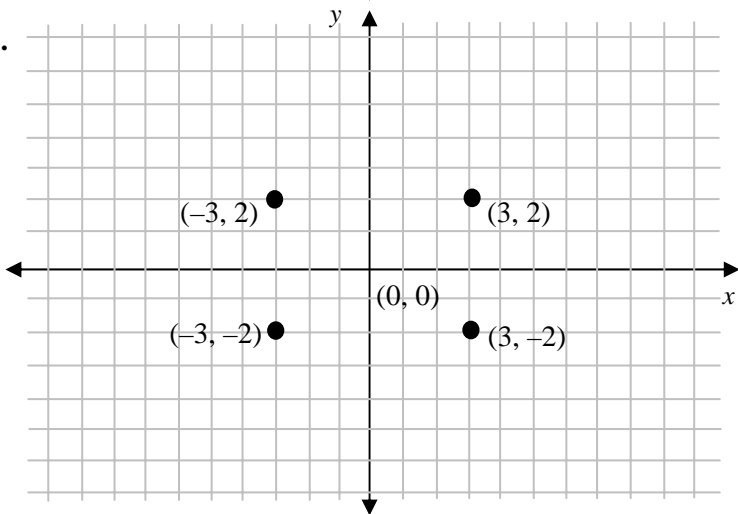

The points are the vertices of a rectangle. They are symmetric around the origin.

4. a) *Sample response:* (1, -1)  
d) (-8, -5)

b) *Sample response:* (-20, -20)  
e) (-3, -4)

c) *Sample response:* (-2, 20)  
f) (-12, -2)

5. P

6. *Sample response:* (2, 3) and (-5, -4)

7. a) *Sample response:* (-1, -5)

[b] When I connected the points with a line, (-1, -5) was between them on the line.]

8. *Sample responses:*

a)

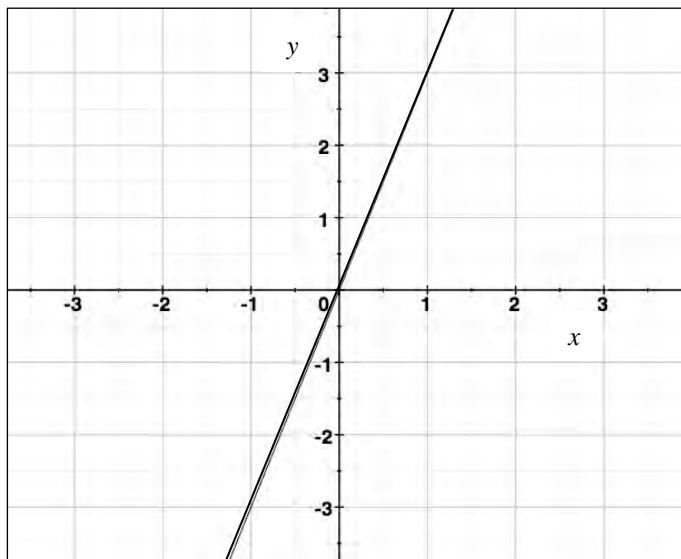

Quadrant I point (1, 3)  
Quadrant III point (-1, -3)

b)

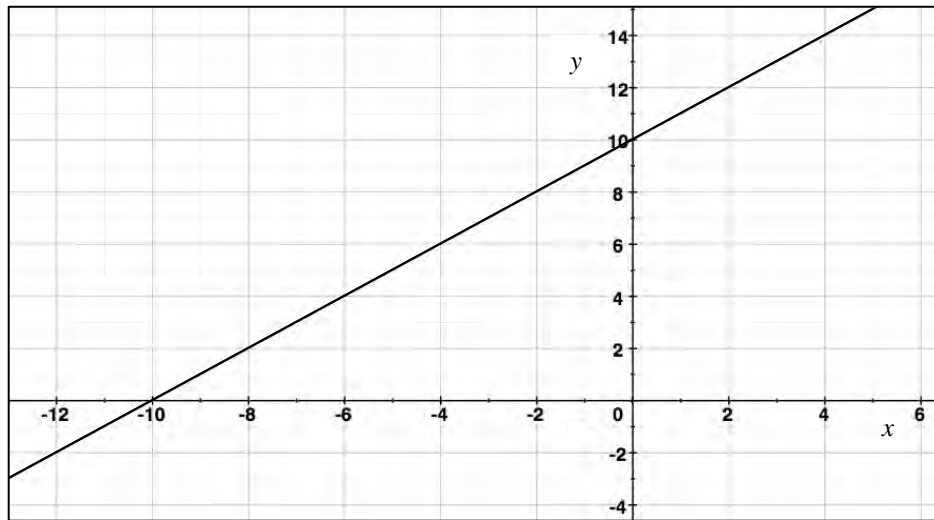

Quadrant I point (2, 12)  
Quadrant II point (-2, 8)  
Quadrant III point (-12, -2)

9. They are equally far from the origin.

[10. Once the origin is defined, you can know where to go by telling how far up or down and how far to the left or right. Any point can be measured up or down and left or right from the origin.]

## Supporting Students

### *Struggling students*

- If students struggle to graph negative coordinates, you may wish to have them draw arrows to the right and left of the  $y$ -axis and up and down from the  $x$ -axis and mark the + and – directions for each until they get used to them.

### *Enrichment*

- Some students might create questions like **question 4 or 5** for other students to solve.

## GAME: Four in a Line

- Students need grid paper to play this game.
- The game allows students to practise plotting coordinate pairs. If students play multiple games, they may wish to take turns going first.
- Students should consider both how to get four of their own marks in a line and how to prevent the other player from getting four in a line by blocking him or her, i.e., deliberately marking a coordinate pair so that the opponent cannot use it.

## Chapter 3 Statistics and Probability

### 7.3.1 Mean, Median, and Mode

Curriculum Outcomes	Outcome relevance
<b>6-F6 Mean, Median, and Mode: concepts</b> <ul style="list-style-type: none"> <li>understand conceptually           <ul style="list-style-type: none"> <li>the mean is the average calculated by taking the total amount of the pieces of data and sharing it equally among the pieces of data</li> <li>the median is another type of average; it is the middle number in an ordered set of data</li> </ul> </li> <li>understand that the mean and median may be the same or may be different</li> <li>understand that the mode is a type of average; it shows the data that appear most often</li> </ul>	Different measures of central tendency are used to summarize data. Although the mean is used most often, sometimes the median and mode are also used. It is important that students understand the differences between these and what each value actually represents.

Pacing	Materials	Prerequisites
1 h	None	<ul style="list-style-type: none"> <li>familiarity with the term <i>mean</i></li> </ul>

#### Main Points to be Raised

- The mean of a set of data tells the amount of one share if the numbers were totalled and then shared equally among the number of data values.
- The sum of the differences between the mean and values higher than the mean balances the sum of the differences between the mean and values lower than the mean.
- The median is the middle number in a set of numbers when they are placed in order. There are as many data values above the median as below the median. If there is an even number of data values, the median is the mean of the two middle numbers.
- The mode is the value that occurs most often in a data set. There is not always a mode and sometimes there is more than one mode.
- You can find the mean, median, and mode for numerical data, but you can only find the mode for non-numerical data.

#### Try This — Introducing the Lesson

**A.** Allow students to try this alone or with a partner. While you observe students at work, you might ask questions such as the following:

- Why did you not choose 218?* (It is the lowest number; most of the numbers are in the 300s.)
- Why did you not choose a number in the 400s?* (Only one number was that high, so it does not really represent all the values very well.)
- How did you decide on 325?* (Two of the numbers were exactly 325, two were higher, and two were lower, so it seemed like it was in the middle of all the numbers.)

#### The Exposition — Presenting the Main Ideas

- Ask five different students to select their favourite number between 1 and 20.
- Show students how you calculate the mean, median, and mode of those five numbers. If there is no mode, repeat one of the five numbers and show what the mode is. Recalculate the mean and median to see how they change with the inclusion of this extra number.
- On the board, write the words *mean*, *median*, and *mode* and ask students to provide their own definitions for these terms. Once a student has offered a correct definition, record it on the board so other students can see it.
- Tell students that they can read the exposition on **pages 208 and 209** of the student text for reference later on.

#### Revisiting the Try This

**B.** Students practise the calculation of the three measures of central tendency with the data they used in **part A**.

## Using the Examples

- Have students work in pairs. One student in each pair should become an expert on **example 1** and the other should become an expert on **example 2**. After each learns his or her example, he or she should explain the ideas to the other student.

## Practising and Applying

### Teaching points and tips

**Q 1:** Students have a chance to practise calculating each measure of central tendency.

**Q 2:** This question has a problem-solving aspect to it.

**Q 4:** Students can choose the values they wish. There are many possibilities. Struggling students might select an easier option.

**Q 5 and Q 7:** Students must think about typical ages of the people in Sonam's family or the typical masses of the animals in order to solve the problem.

**Q 8:** Students might discuss this question in small groups and then share their thinking with the class.

### Suggested assessment questions from Practising and Applying

<b>Question 1</b>	to see if students can calculate a mean, median, and mode for a set of data
<b>Question 2</b>	to see if students can calculate a missing value if a mean, median, or mode is known
<b>Question 4</b>	to see if students can create a set of data with a particular mean, median, or mode
<b>Question 8</b>	to see if students can discuss what the measures of central tendency reveal about a data set

## Answers

<b>A. Sample response:</b> 325 because it happened twice and it is in the middle.	<b>B.</b> Mean = $329\frac{2}{3}$ , median = 325, mode = 325
<b>1. a)</b> Mean = 4, median = 3, modes = 1, 2, and 7 <b>b)</b> Mean = 2, median = 1.5, mode = 0 <b>c)</b> Mean = 4, median = $2\frac{1}{2}$ , mode = 3 <b>d)</b> Mean = 3, median = 3, mode = 3	<b>c)</b> Yes; [If both her parents were the same age.]
<b>2. a)</b> 2 <b>b)</b> 1 <b>c)</b> 8	<b>6.</b> 4
<b>3. a)</b> Mean <b>b)</b> All are equal <b>c)</b> Mean	<b>7. a)</b> The median is less than the tiger's mass; [Sample response: It is the average of the dog's and the tiger's mass, and the dog is smaller.] <b>b)</b> The mean is greater than the tiger's mass; [Sample response: Since the elephant is so big, it adds a lot to the mean.]
<b>4. Sample responses:</b> <b>a)</b> 2, 3, 4, 6, 8, 10 <b>b)</b> 3, 6, 6, 6 <b>c)</b> 1, 1, 3, 8, 10	<b>[8. Sample response:</b> • The mean is typical because it means sharing everything fairly. • The median is typical because it is right in the middle. • The mode is typical because it happens most often.]
<b>5. a)</b> Greater; [She is the second in order from least to greatest and the median is between her age and one of her parents' ages.] <b>b)</b> Greater; [There are two much higher values (her parents) compared to two low values.]	

## Supporting Students

### Struggling students

- Some students will have difficulty creating sets of data to fit conditions or determining missing numbers if they are given some of the data values and a condition. You may need to model a few more of these problems for those students.

For example, to help them with **question 4 a)**, you might show how you could start with a set of 5s and then adjust one or two numbers so the median is still 5.

### Enrichment

- Students might create sets of data to fit more complicated conditions.

For example, conditions might be that

the mean is 5 and the median is 2, or the mode is 4 more than the mean, or the median is 2 less than the mode.

## 7.3.2 Theoretical Probability

Curriculum Outcomes	Outcome relevance
<p><b>6-G2 Theoretical Probability: determine</b></p> <ul style="list-style-type: none"> <li>• understand that theoretical probability is number of favourable outcomes divided by the number of possible outcomes</li> <li>• use fractions, decimals, and percents to describe probabilities</li> <li>• identify events that might be associated with a particular theoretical probability</li> </ul>	<p>The development of probability concepts is gradual. Students have already worked with experimental probability, but now the focus is on analysing situations to determine theoretical probability.</p> <p>Theoretical probability is often used to make predictions about future events. This outcome extends students' previous work with theoretical probability to using percents and describing events with particular probabilities.</p>

Pacing	Materials	Prerequisites
1 h	<ul style="list-style-type: none"> <li>• Fraction Circles for Spinners (BLM)</li> </ul>	<ul style="list-style-type: none"> <li>• familiarity with theoretical probability</li> <li>• familiarity with the term <i>multiple</i></li> <li>• calculating equivalent fractions, decimals, percents</li> </ul>

### Main Points to be Raised

- The theoretical probability of an event is the fraction of the time you expect the event to occur.
- Theoretical probability is defined as the fraction  $\frac{\text{number of favourable outcomes}}{\text{number of possible outcomes}}$ .
- A theoretical probability can be described as a fraction, a decimal, or a percent.
- To create an event with a particular probability, create a situation where the number of possible outcomes is the denominator you want and the number of favourable outcomes is the numerator you want.

### Try This — Introducing the Lesson

A. Allow students to try this alone or with a partner. While you observe students at work, you might ask questions such as the following:

- *What numbers are the multiples of 5?* (The numbers that end in 5 or 0, like 5, 10, 15, 20, ...)
- *How many multiples of 5 are there between 1 and 100?* (There are 20.)
- *How does that help you calculate the probability?* (I know that 20 numbers out of 100 are multiples of 5, so I can use the fraction  $\frac{20}{100}$ .)

### The Exposition — Presenting the Main Ideas

- Work through the exposition with the students. You may wish to provide a few more examples of situations where probabilities are given as fractions, decimals, or percents.

### Revisiting the Try This

B. Students practise creating an event with a particular probability. They may wish to use the equivalent fraction  $\frac{1}{5}$  to simplify their work.

### Using the Examples

- Present the questions in the example to students and let them try to answer before they look at the solution in the student text.

## Practising and Applying

### Teaching points and tips

**Q 2:** This question helps students think about the fact that the outcomes must be equally likely when they set up the number of outcomes as the denominator of the theoretical probability.

**Q 3:** Students need to realize that they must count both the number of favourable outcomes and the number of possible outcomes, which is always 100 in this situation.

**Q 4:** Students do not need to say what letter or number is written on the slips, but simply whether it is a letter or a number.

**Q 5:** Students have the opportunity to recognize the equivalence of fraction, decimal, and percent forms of a probability. They should realize that it is easiest to think of an event if they use the fraction form.

**Q 6:** This might be handled in a group discussion.

### Common errors

- Some students do not think about how the likelihoods of the possible outcomes compare when they calculate theoretical probabilities. Provide more situations like **question 2** so that students can see that the size of the sections on the spinner matters as much as the labels on the sections.

### Suggested assessment questions from Practising and Applying

<b>Question 1</b>	to see if students can determine a theoretical probability
<b>Question 5</b>	to see if students can create events to match theoretical probabilities

### Answers

<p><b>A.</b> <math>\frac{1}{5}</math>; there are 20 multiples of 5 in the numbers 1 to 100, and <math>\frac{20}{100} = \frac{1}{5}</math>.</p>	<p><b>B. Sample response:</b> Spinning a spinner with 5 equal sections where one section is grey and you want to know the probability of landing on the grey section.</p>
<p><b>1. a)</b> <math>\frac{2}{6}</math>                      <b>b)</b> <math>\frac{3}{6}</math>  <b>c)</b> <math>\frac{1}{2}</math>                        <b>d)</b> <math>\frac{1}{5}</math></p> <p><b>2.</b> No; [The section for 2 is not <math>\frac{1}{5}</math> of the spinner.]</p> <p><b>3. a)</b> <math>\frac{50}{100}</math>                      <b>b)</b> <math>\frac{30}{100}</math>  <b>c)</b> <math>\frac{58}{100}</math>                        <b>d)</b> <math>\frac{16}{100}</math></p> <p><b>4. Sample response:</b> 9 slips; 4 with numbers and 5 with letters.</p>	<p><b>5. Sample responses:</b>  <b>a)</b> Rolling a number greater than 4 on a die.  <b>b)</b> Drawing a slip of paper with a * from a bag that contains 2 slips with a * and 2 other slips.  <b>c)</b> Spinning grey on a spinner with 5 equal sections: 3 grey sections and 2 white sections.  <b>d)</b> Choosing a slip of paper with a * from a bag that contains 8 slips: 3 slips with a * and 5 other slips.  <b>e)</b> Choosing a slip of paper with a * from a bag that contains 8 slips: 2 slips with a * and 6 other slips.  <b>f)</b> Spinning a number less than 5 using the spinner in question 1.</p> <p><b>6.</b> Drawing slips from a bag and spinning a spinner; [Sample response: Slips: The denominator tells me how many slips of paper to put in the bag and the numerator tells me how many slips should be favourable. Spinner: The denominator tells me how many equal sections the spinner must have and the numerator tells me how many sections should be favourable.]</p>

## Supporting Students

### *Struggling students*

- Some students may have difficulty with **question 2**. You may have to conduct an experiment to help them see that 1 and 2 come up more often than 3, 4, and 5 if the spinner is spun enough times.
- **Question 4** may be difficult for some students. You may have to ask some questions to help them.

For example, you might ask:

- *Could there be 5 slips of paper in the bag? Why not?*
- *Could there be 9 slips of paper in the bag?*
- *Could there be a number on 5 slips of paper? Why not?*

### *Enrichment*

- Students might create spinners with a fixed number of sections, for example, 4 sections, where the probability of spinning a certain number is given, but not in fourths. For example, the probability might be  $\frac{1}{2}$  or  $\frac{1}{5}$ .



# UNIT 7 Revision

Pacing	Materials
2 h	<ul style="list-style-type: none"> <li>• Dice</li> <li>• Grid paper or Small Grid Paper (BLM)</li> <li>• Fraction Circles for Spinners (BLM)</li> </ul>

Question(s)	Related Lesson(s)
1 and 2	Lesson 7.1.1
3	Lesson 7.1.2
4 and 5	Lesson 7.2.1
6 – 8	Lesson 7.2.2
9 – 11	Lesson 7.2.3
12 – 15	Lesson 7.2.4
16 – 19	Lesson 7.3.1
20 and 21	Lesson 7.3.2

## Revision Tips

**Q 2:** Make sure students understand that the conclusion has to be about all people in Bhutan since no subgroup is specified.

**Q 4:** Have students consider why a double bar graph with intervals is appropriate in this situation.

**Q 9:** Students should record the actual rolled values. They can then create a list of the calculated values.

**Q 14:** If necessary, remind students that the opposite of a number is equally far from zero on the other side of the number line.

**Q 15:** Some students may need a quick reminder of how to rotate and reflect.

**Q 18:** If necessary, help students locate the four locations on a map of Bhutan.

## Answers

**1. a)** People at the hospital are sicker than most.

**b) Sample response:**

I could ask some doctors how many patients they have and how many have been sick this year.

**2. Sample responses:**

**a)** Students might watch a different amount of TV than adults.

**b)** Fewer people would have TVs in rural areas than in urban areas.

**3. Sample responses:**

**a)** Sums are 3 and 9.

**b)** 50%

**c)** For a total of 25 rolls:

3	9	4	8	6	9	5	9	6
7	4	8	11	7	11	5	6	10
7	7	8	8	5	7	12	7	6

7 or less	Greater than 7
15	10

Experimental probability of a sum > 7:  $\frac{10}{25} = 40\%$

**d)** No; [looks like the probability might be 40%.]

**4. a)**

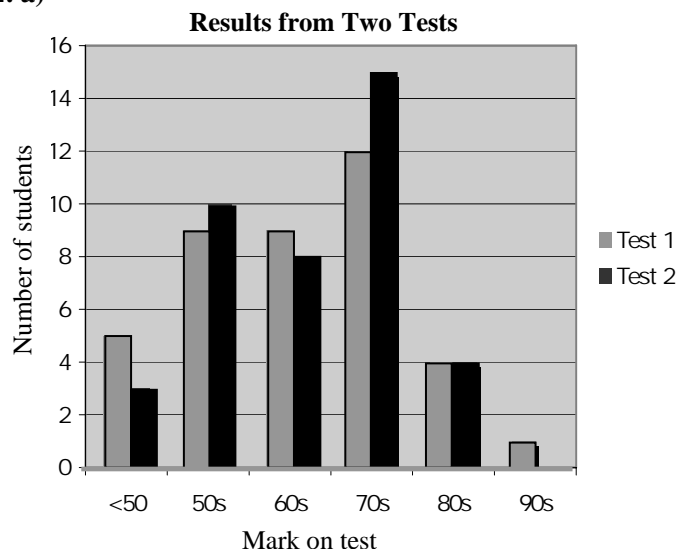

**b) Sample response:**

Test 2 marks improved for marks in the 70s, stayed the same for marks in the 80s, but dropped for marks in the 90s. Marks lower than 50 dropped, which shows an improvement.

**Answers [Continued]**

**5. a)**

**Results from Two Tests**

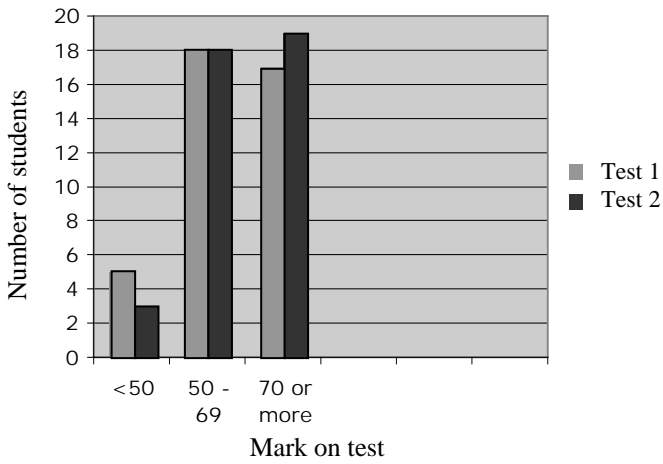

**b) Sample response:**

You can still see that there are fewer marks below 50, but you cannot see which category improved the most for marks greater than 70.

**6. a) Tens digit**

**b) Sample response:** Hundreds digit

**c) Sample response:** Hundreds digit

**7. 31, 32, 33, 40, 41, 41, 51**

**8. a)**

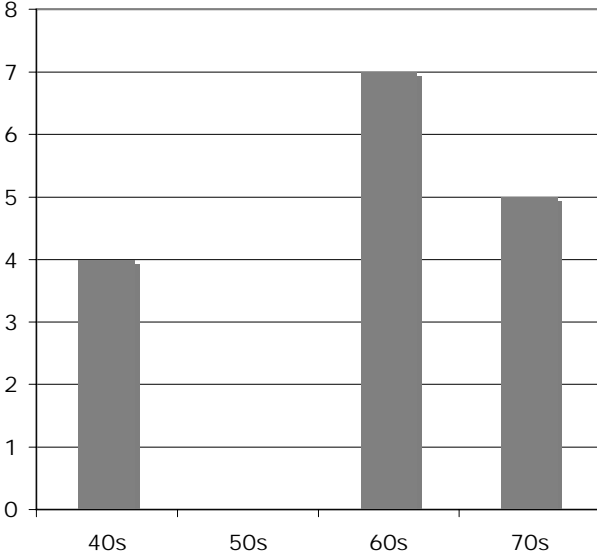

**b)**

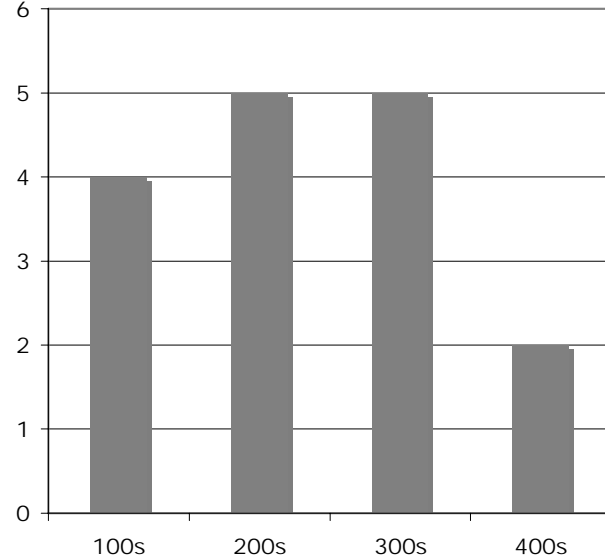

**9. Sample response:**

**Rolls:**

3, 3	5, 3	4, 5	1, 2	6, 4	2, 5	5, 6	3, 2	6, 6	1, 1	4, 4	3, 5	2, 5	5, 6	6, 2
5, 4	2, 1	3, 5	4, 3	1, 5	5, 1	5, 2	2, 2	3, 1	5, 3	1, 3	6, 4	6, 3	4, 1	1, 4

**Values after I double and add:**

12	16	18	6	20	14	22	10	24	4	16	16	14	22	16
18	6	16	14	12	12	14	8	8	16	8	20	18	10	10

0	4	6	6	8	8	8												
1	0	0	0	2	2	2	4	4	4	4	6	6	6	6	6	8	8	8
2	0	0	2	2	4													

10. B

11. a)

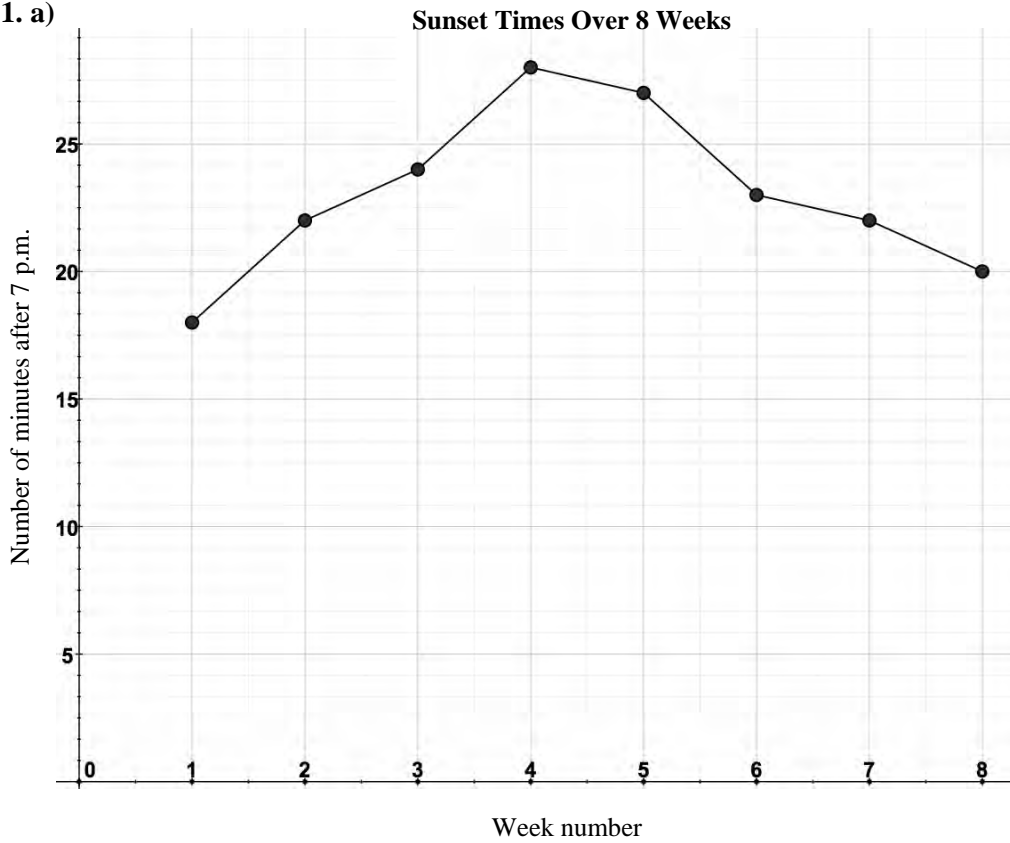

b) The sunset time was getting later for a while, but then it started to get earlier.

12. A(-5, 1), B(-2, 3), C(-4, -3), D(0, -1)

13.

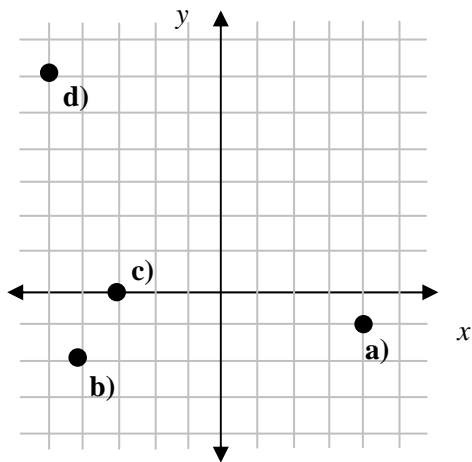

14.

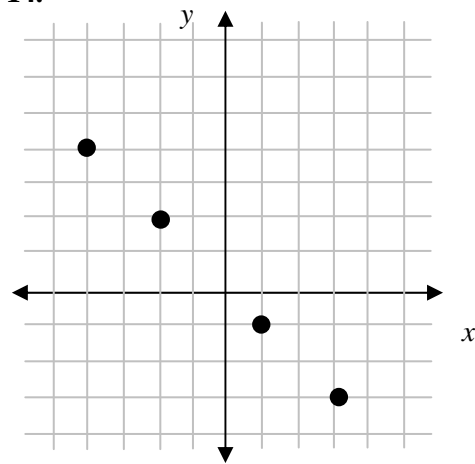

*Sample response:*  
The points are all in a line.

**Answers [Continued]**

**15. Sample response:**

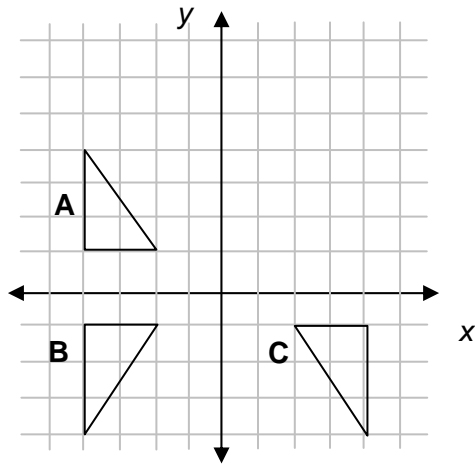

- b)** The  $x$ -coordinates are the same but the  $y$ -coordinates are opposites.
- c)** The  $x$ - and  $y$ - coordinates are opposites; the  $y$ -coordinates are the same but the  $x$ -coordinates are opposites.

**16. a) Sample response: 2**

**b) Sample response: 2** or any other number that is not already on the list

**c) 9**

**17. a) Mode or median**

**b) Mean**

**c) Median or mode**

**18. a) Greater; [Gasa is in the north and is coldest.]**

**b) Less; [Samtse would have higher temperatures, and the lower temperatures in Thimphu and Gasa would bring the mean down.]**

**19. Sample responses: a) 20      b) 20**

**20. a)  $\frac{2}{6}$                       b)  $\frac{3}{5}$**

**21. Sample responses:**

**a) Spinning grey on a spinner with 10 sections where 1 section is grey**

**b) Spinning grey on a spinner with 10 sections where 2 sections are grey**

## UNIT 7 Data and Probability Test

1. Give an example of a biased sample.
2. Suppose you want to know the amount of rent most people in Bhutan pay. If you ask only children in Thimphu, why will your sample be biased?
3. Dechen and Lobzang kept track of the number of minutes they walked each day for a week.

<b>Dechen</b>	90	95	88	90	30	30	35
<b>Lobzang</b>	65	65	60	55	80	25	30

- a) Create a double bar graph to compare their walking times. Use intervals on the horizontal axis and a scale on the vertical axis.
  - b) Choose different intervals to show the same data.
  - c) Which graph gives more information? Why?
4. a) Create a stem and leaf plot for this set of data:  
47, 38, 17, 29, 52, 30, 41, 47, 18, 17, 2, 61
- b) Show the same data in a bar graph with the same intervals as the stem and leaf plot.
5. Chhimi kept a record of his mass (in kilograms) each May for several years.

2002	2003	2004	2005	2006	2007	2008
68	70	74	73	71	71	70

- a) Draw a line graph to show the data.
  - b) Describe the trend in Chhimi's mass.
6. Sketch a line graph that represents the following trend:
- The number of people in a shop increased from 10 a.m. to 12 noon.
  - The number of people then increased a lot from noon to 1 p.m.
  - Then the number of people decreased very greatly until 3 p.m.
  - The number of people then decreased a little from 3 p.m. to 6 p.m.

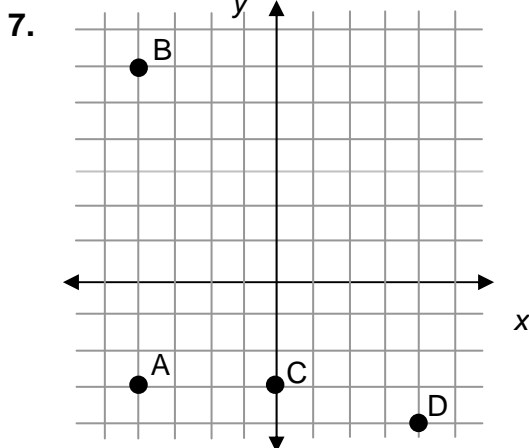

- a) Use coordinates to name the four labelled points on the grid above.
  - b) Give the coordinates of a fifth point that is closer to A than to C.
8.  $(4, -5)$  and  $(11, 2)$  are the vertices of a parallelogram. What might be the coordinates of the two other vertices?
9. A rectangle is drawn on a coordinate grid. In how many quadrants could the points on the perimeter of the rectangle be located? Explain your thinking using examples.
10. The ages of a group of people at a party are listed below.  
9, 12, 35, 35, 58, 56, 45, 21, 8
- a) What is the mean age?
  - b) What is the median age?
  - c) What is the mode age?
11. Change two values in the data in **question 10** so that the mean changes but the median and mode do not change.
12. The median and mean of this set of numbers is 8. What is the missing number?  
10, 15, 2, 5, 7, ?
13. Describe two events that match each probability.
- a) 0.6
  - b) 25%
  - c)  $\frac{2}{3}$

# UNIT 7 Test

Pacing	Materials
1 h	• Grid paper or Small Grid Paper (BLM)

Question(s)	Related Lesson(s)
1 and 2	Lesson 7.1.1
3	Lesson 7.2.1
4	Lesson 7.2.2
5 and 6	Lesson 7.2.3
7 – 9	Lesson 7.2.4
10 – 12	Lesson 7.3.1
13	Lesson 7.3.2

Select questions to assign according to the time available.

## Answers

### 1. Sample response:

If you want to know the number of years of schooling most Bhutanese people have had and you only ask 6-year-olds, the sample is biased.

### 2. Sample response:

Rents are higher in Thimphu and children probably do not know how much rent their parents are paying.

### 3. a)

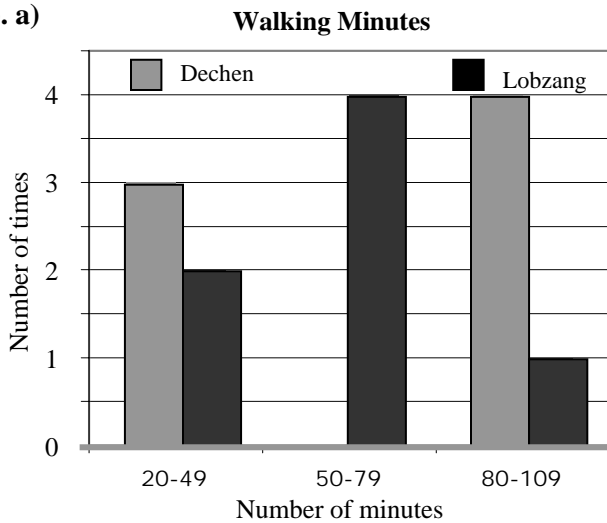

### b)

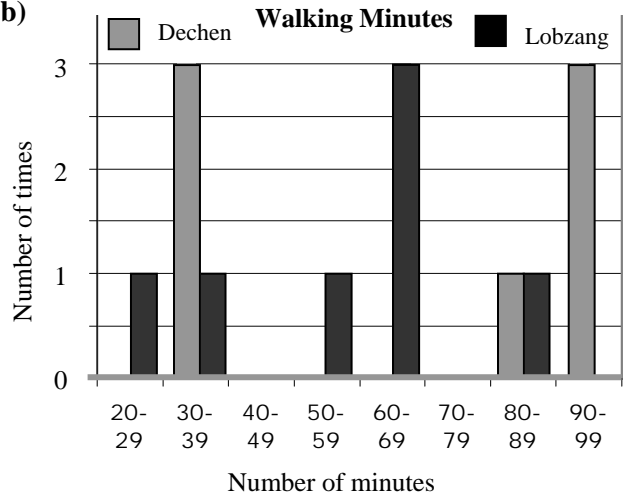

### c) Sample response:

The second graph; It shows that Lobzang walked for about the same amount of time on four days. It shows that Dechen walked for about the same amount of time on two days. The first graph does not show that.

### 4. a)

0	2		
1	7	7	8
2	9		
3	0	8	
4	1	7	7
5	2		
6	1		

### b) Sample response:

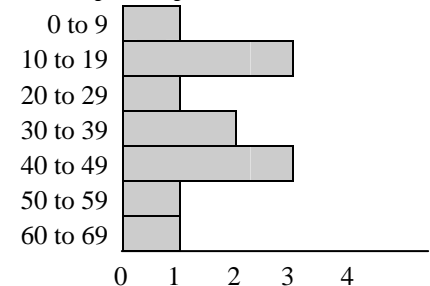

**5. a) Change in Chhimi's Mass Over Time**

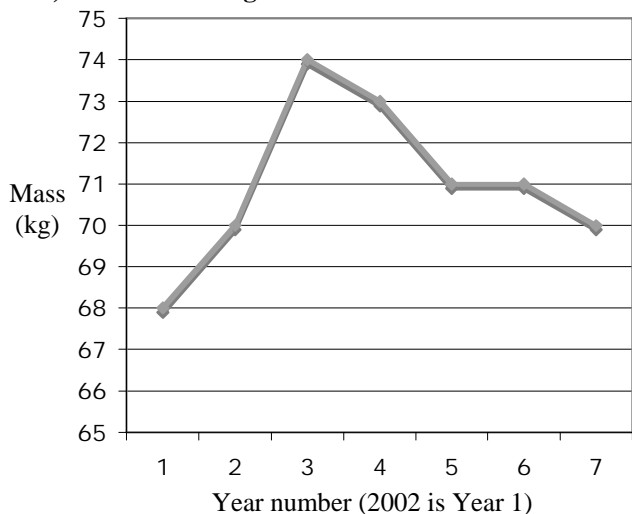

**b) Sample response:**

Chhimi's mass increased for two years and then it decreased for four years except for one year when it did not change at all.

**6. Sample response:**

**People in a Shop**

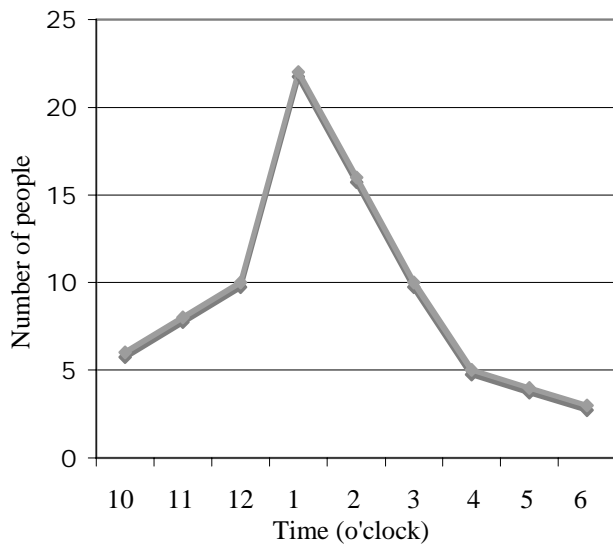

**7. a) A (-4, -3); B (-4, 6); C (0, -3); D (4, -4)**

**b) Sample response: (-5, 0)**

**8. Sample response: (-2, 2), (17, -5)**

**9. 1, 2, 3, or 4 quadrants;**

*Sample response:*

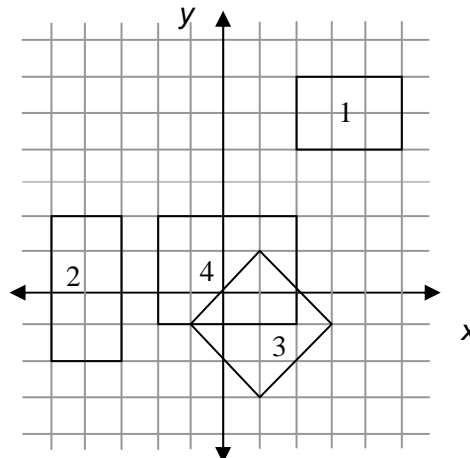

**10. a) Mean = 31    b) Median = 35    c) Mode = 35**

**11. Sample response:**

9, 12, 35, 35, 78, 66, 45, 21, 8

**12. 9**

**13. Sample responses:**

**a)** Drawing a slip with a number greater than 4 from a bag with 10 slips in it numbered 1 to 10; Spinning a 1 on a spinner with five equal sections where three sections are labelled 1 and two are labelled 2.

**b)** Spinning A on a spinner with four equal sections marked A, B, C, D;

Drawing a slip with a number 10 or less from a bag with 40 slips in it numbered 1 to 40.

**c)** Choosing a red cube from a bag with 2 red cubes and 1 green cube;

Spinning a number less than 5 on a spinner with 6 equal sections marked 1, 2, 3, 4, 5, and 6.

## UNIT 7 Performance Task — Typing Speed

Choki practises every day on a computer to increase her typing speed.

Each day she gives herself a typing test to see how many words she can type in one minute.

The charts below show Choki's data for two weeks.



### Week 1

Day number	Day 1	Day 2	Day 3	Day 4	Day 5	Day 6	Day 7
Typing speed (Number of words typed in one minute)	17	20	20	22	19	24	26

### Week 2

Day number	Day 1	Day 2	Day 3	Day 4	Day 5	Day 6	Day 7
Typing speed (Number of words typed in one minute)	25	27	28	28	30	30	29

**A. i)** Create a double bar graph with intervals to compare her typing speeds in Week 1 with her speeds in Week 2.

**ii)** List three things that the graph shows.

**B.** Combine the data from both weeks and then graph the data in a stem and leaf plot.

**C.** Create a line graph to show Choki's typing speed over the two weeks. Describe the trend.

**D.** Which graph do you think best describes Choki's typing speed?

- the double bar graph,
- the stem and leaf plot, or
- the line graph

Explain your thinking.

**E.** Calculate each for Week 1 and for Week 2.

**i)** mean typing speed    **ii)** median typing speed    **iii)** mode typing speed

**F.** In Week 3, Choki's mean typing speed increased over Week 2 but her median speed was the same. The mode for Week 3 was the same as one of the modes from Week 2.

**i)** Create a set of seven possible typing speeds for Week 3. Explain how you created the set.

**ii)** Show how you know your set is possible.



## UNIT 7 Performance Task

Curriculum Outcomes Assessed	Pacing	Materials
<b>6-F2</b> Bar and Double Bar Graphs: construct and interpret <b>6-F3</b> Stem and Leaf Plots: grouping and displaying data <b>6-F4</b> Line Graphs: construct and interpret <b>6-F6</b> Mean, Median, and Mode: concepts	1 h	<ul style="list-style-type: none"> <li>• Grid paper or Small Grid Paper (BLM)</li> </ul>

### How to Use This Performance Task

- You might use this task as a rich problem to assess student understanding of a number of outcomes in this unit. It could supplement the unit test. It could also be used as enrichment material for some students.
- You can assess performance on the task using the rubric on the next page.

### Sample Solution

#### A. i) Typing Speed Over Two Weeks

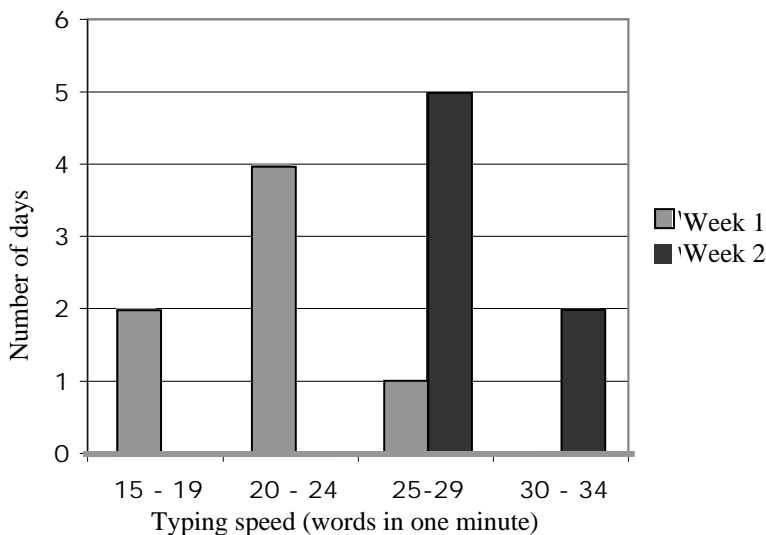

#### ii) The graph shows:

- Choki's typing speed improved from Week 1 to Week 2.
- The typical speed in Week 1 was 20 to 24 words in one minute. In Week 2, it was 25 to 29 words in one minute.
- Choki never typed faster than 34 words in one minute.

**B.**

1	7	9								
2	0	0	2	4	5	6	7	8	8	9
3	0	0								

**Sample Solution [Continued]**

**C. Choki's Typing Speed Over Two Weeks**

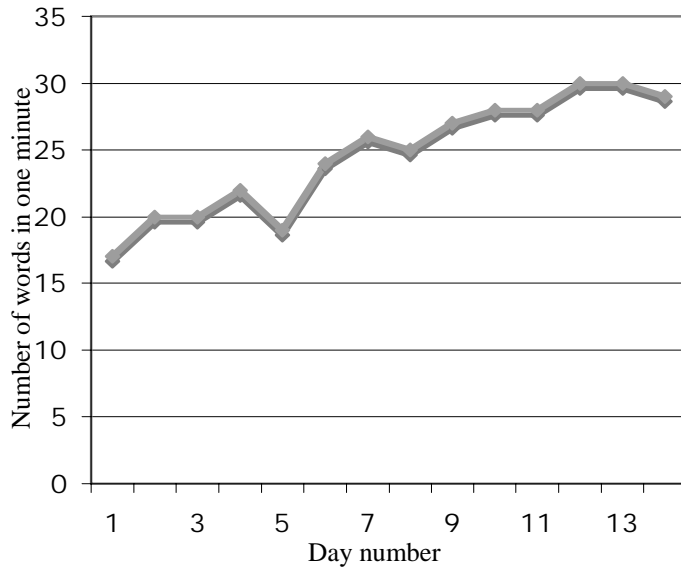

Choki's typing speed improved over the two weeks, except for a big decrease (from 22 to 19) on Day 5 and two small decreases on Day 8 (from 26 to 25) and Day 14 (from 30 to 29).

**D.** The line graph describes Choki's typing speed best because it shows the trend over two weeks. The double bar graph does not describe the changes in Choki's typing speeds over the two weeks as well as the line graph because it does not show the slips backward like the line graph does. The stem and leaf plot does not show how her typing speed changed over the 14 days; it just graphs all the speeds in order so you can tell whether or not she got faster.

- E. i)** Week 1: 21.1 words in one minute; Week 2: 28.1 words in one minute.  
**ii)** Week 1: 20 words in one minute; Week 2: 28 words in one minute.  
**iii)** Week 1: 20 words in one minute; Week 2: 28 and 30 words in one minute.

**F. i)** 25, 26, 27, 28, 30, 30, 37;

I drew seven blanks for the seven numbers so I could put them in order from least to greatest. Then I put 28 in the middle blank so it would be the median.

— — — 28 — — —

I put two 30s in the next two blanks. I decided not to repeat any other numbers so 30 could be the mode.

— — — 28 30 30 —

I put 25, 26, and 27 in the first three blanks so the mean would be as high as possible.

25 26 27 28 30 30 —

I tried different values in the last blank until I found a value that increased the mean from 28.1 to 29.

25 26 27 28 30 30 37

**ii)** The mean is 29 (up from 28.1 in Week 1), the median is 28 (the same as Week 2), and the mode is 30 (one of the modes from Week 2).

## UNIT 7 Performance Task Assessment Rubric

<i>The student</i>	<b>Level 4</b>	<b>Level 3</b>	<b>Level 2</b>	<b>Level 1</b>
<b>Constructs graphs and calculates statistics</b>	Insightfully and accurately constructs a double bar graph, a stem and leaf plot, and a line graph, and correctly calculates the mean, median, and mode(s)	Accurately constructs a double bar graph, a stem and leaf plot, and a line graph with few minor errors, and correctly calculates the mean, median, and mode(s)	Accurately constructs at least two of the graphs (double bar graph, stem and leaf plot, and line graph) with minor errors, and correctly calculates two of the mean, median, and mode(s)	Has difficulty constructing two or three of the graphs and two or three of the mean, median, and mode(s)
<b>Draws conclusions from graphs and statistics</b>	Insightfully draws conclusions from the double bar graph and the line graph; recognizes and communicates clearly and concisely about which graph is most useful and why	Draws correct conclusions from the double bar graph and the line graph; recognizes and communicates reasonably clearly about which graph is most useful and why	Draws some correct conclusions from the double bar graph and line graph; communicates somewhat effectively about which graph is most useful and why	Has difficulty drawing appropriate conclusions from the graphs; has difficulty communicating about which graph is most useful and why
<b>Creates a set of data for given conditions</b>	Creates a suitable set of data using a strategy that shows a solid understanding of mean, median, and mode; communicates clearly and concisely about why the data set is suitable	Creates a suitable set of data using a strategy that shows a reasonable understanding of mean, median, and mode; communicates reasonably clearly about why the data set is suitable	Creates a suitable set of data using an inefficient strategy, such as guess and test, that shows a superficial understanding of mean, median, and mode; communicates ineffectively about why the data set is suitable	Has difficulty creating a suitable set of data and communicating about why the data set is suitable

# UNIT 7 Blackline Masters

## BLM 1 Fraction Circles for Spinners

